

AKR5000/IX



- ★ LED Sensor Touch Control
- ★ Slim Front Panel Design
- ★ LED Lighting



Basic Specifications

- Max. extraction (unrestricted) : 1200m³/hr
- Number of motor : 1
- Number of lamp : 2 x 2W (LED light)
- Length of chimney (lower / upper) : 480 / 475mm
- Diameter of air duct : 170mm
- Socket / Fuse spur unit : 13A
- Length of power cord : 1300mm
- Product Dimensions (mm) : 535-964H x 900W x 487D
- Colour : Stainless Steel
- Country of origin : Asia

Special Features

- Extraction or Recirculation operation
- LED sensor touch control
- Number of speeds : 4
- Delay off
- Stainless steel filter : 3
- Slim front panel design
- LED Lighting

INSTALLATION

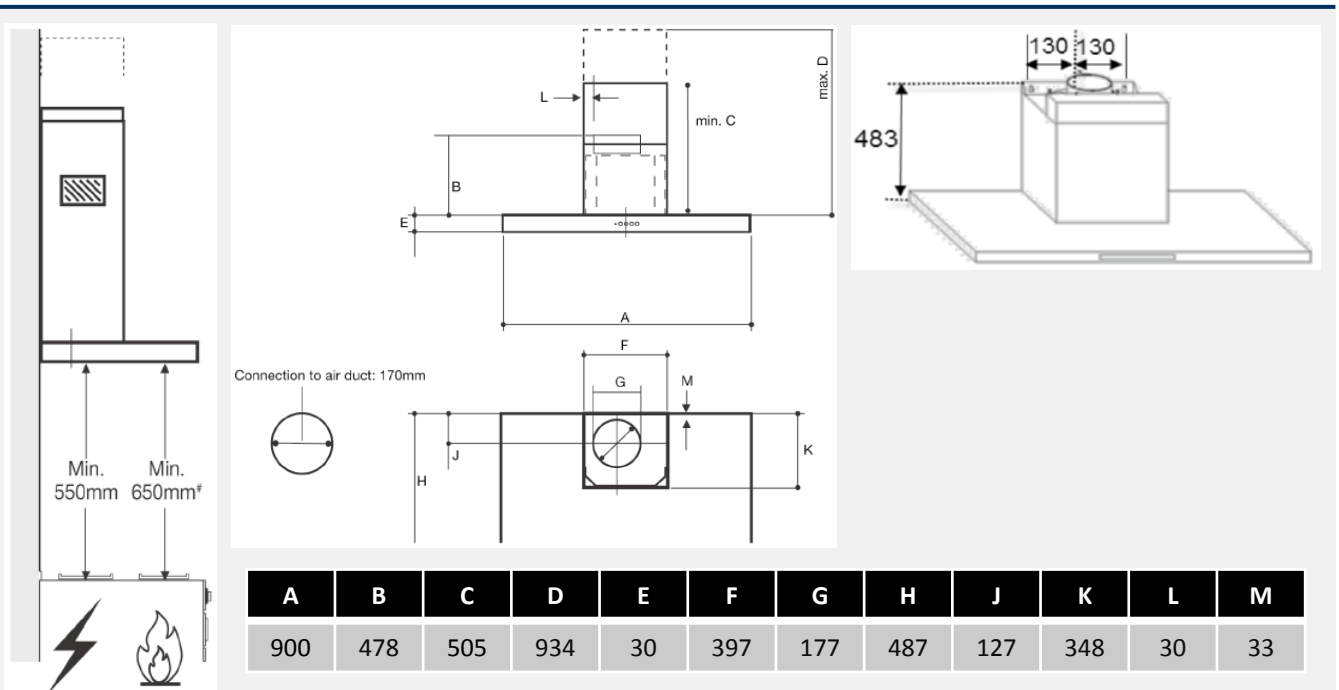

* For recirculation type, no exhaust duct is needed but carbon filter must be installed.
 # From upper edge of pan support.

Unit: mm
 Above diagram is not to scale