

AMW 842/IX – Multi-Functional Microwave Oven

Features

- 14 Heating methods: Microwave, Grill, Turbo Grill, Turbo Grill + Microwave, Forced Air, Forced Air + Microwave, 6th Sense Steam, 6th Sense Reheat, 6th Sense Crisp, Jet Defrost, Quick Heat, Soften, Melt, Crisp
- Auto recipes
- 7 Power levels
- 3D Emission system
- Doneness selection
- Jet start
- Electronic text assisted LED display
- Variable temperature setting
- Favorite shortcuts
- Eco mode
- Clock and Timer
- Frameless design
- Child lock
- Retractable knobs
- Anti fingerprint treatment
- Stainless steel cavity
- Pull down opening
- Colour: Stainless Steel
- Country of origin: Europe

Technical Information

- Capacity: 40L
- Microwave power: 900W
- Grill power: 1600W
- Forced air power: 1200W
- Oven Temp: 100°C - 220°C
- Connection rating: 2800W
- Turntable diameter: 40cm
- Socket / Fuse spur unit: 13A
- Length of power cord: 1200mm
- Product Dimensions (mm): 455H x 595W x 560D
- Cut Out Dimensions (mm): 460H x 560W x 550D

Accessories

- Supplied Accessories
 - Steamer
 - Glass turntable
 - Crisp plate
 - Crisp handle
 - Baking plate
 - Grill grid
 - Baking grid



Installation Diagram

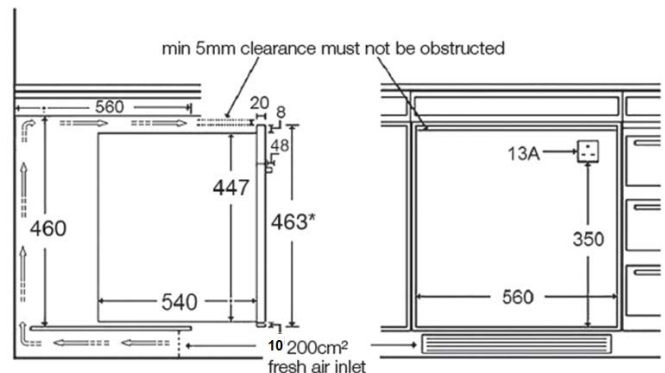
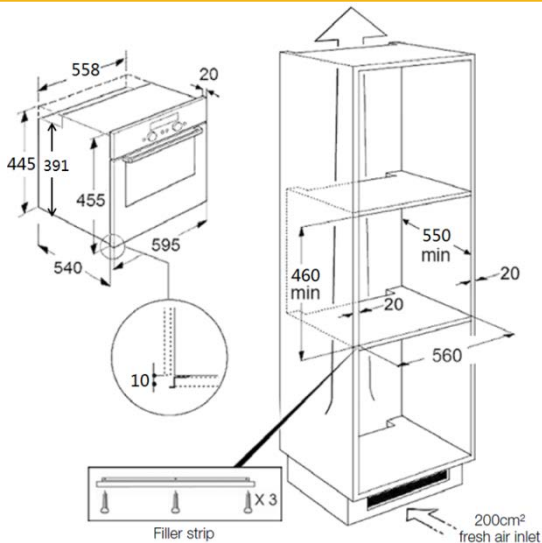

Socket at the back or above appliance
*Height including filler strip

Unit: mm
Above diagram is not to scale