

Whirlpool

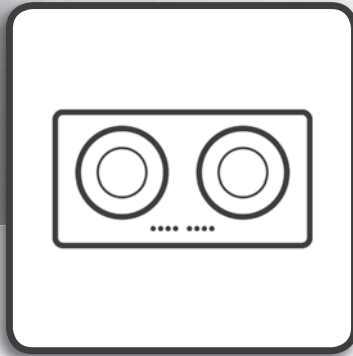

Health & Safety, Use & Care and Installation guide

Model : ACM320/BA



www.whirlpool.com.hk

IMPORANT SAFETY INSTRUCTIONS

YOUR SAFETY AND THAT OF OTHERS IS VERY IMPORTANT

Please read these instructions before installing and using your induction hob and keep it in an easily accessible place for future reference.

All messages relevant to safety specify the potential risk to which they refer and indicate how to reduce the risk of injury, damage and electric shocks due to incorrect use of the appliance. Make sure to comply with the following:

- Use protective gloves to perform all unpacking and installation operations.
- The appliance must be disconnected from the power supply before carrying out any installation operation.
- Installation and maintenance must be carried out by a qualified technician, in compliance with the manufacturer's instructions before carrying out any installation and maintenance operation. Do not repair or replace any part of the appliance unless specifically stated in the user manual.
- The appliance must be earthed.
- The power cable must be long enough for connecting the appliance, fitted in the cabinet, to the power supply.
- For installation to comply with the current safety regulations, an omnipolar switch with minimum contact gap of 3mm is required.
- Do not use multi-sockets or extension cords.
- Do not pull the appliance's power cable.
- The electrical parts must not be accessible to the user after installation.
- The appliance is designed solely for domestic use for cooking food. No other use is permitted (e.g. heating rooms). The Manufacturer declines any liability for inappropriate use or incorrect setting of the controls.
- The appliance and its accessible parts become hot during use. Care should be taken to avoid touching heating elements. Very young (0-3 years) and young children (3-8 years) shall be kept away unless continuously supervised.
- Children from 8 years and above and persons with reduced physical, sensory or mental capabilities or lack of experience and knowledge can use this appliance only if they are supervised or have been given instructions on safe appliance use and if they understand the hazards involved. Children shall not play with the appliance. Cleaning and user maintenance shall not be made by children without supervision.

- Do not touch the appliance heating elements during and after use. Do not allow the appliance to come into contact with cloths or other flammable materials until all the components have cooled down completely.
- Do not place flammable materials on or near the appliance.
- Overheated oils and fats catch fire easily. Pay attention when cooking food products rich in fat and oil.
- A separator panel (not supplied) must be installed in the compartment under the appliance.
- If the surface is cracked, switch off the appliance to avoid the possibility of electric shock (only for appliances with glass surface).
- The appliance is not intended to be operated by means of an external timer or separate remote control system.
- Unattended cooking on a hob with fat or oil can be dangerous and may result in fire. NEVER try to extinguish a fire with water, but switch off the appliance and then cover flame e.g. with a lid or a fire blanket.
Danger of fire: Do not store items on the cooking surfaces.
- Do not use steam cleaners.
- Metallic objects such as knives, forks, spoons and lids should not be placed on the hob surface since they can get hot.
- After use, switch off the hob element by its control and do not rely on the pan detector (only for induction appliances).

SAFEGUARDING THE ENVIRONMENT

Disposal of Packing

The packing material is 100% recyclable and marked with the recycling symbol (). The various parts of the packing must not be dispersed in the environment, but disposed of in compliance with local regulations.

Disposal

This appliance is marked in conformity with European Directive 2012/19/EU on Waste Electrical and Electronic Equipment (WEEE).

By ensuring that this appliance is correctly disposed of, the user can help prevent potentially negative consequences for the environment and health.

The symbol  on the appliance or the accompanying documentation indicates that this product should not be treated as domestic waste but must be taken to an appropriate collection point for recycling WEEE.

Energy Saving Tips

For optimum results, it is advised to:

- Use pots and pans with bottom width equal to that of the cooking zone.
- Only use flat-bottomed pots and pans.
- When possible, keep pot lids on during cooking.
- Use a pressure cooker to save even more energy and time.
- Place the pot in the middle of the cooking zone marked on the hob.

Before Use

IMPORTANT: The cooking zones will not switch on if pots are not the right size.

Only use pots bearing the symbol “INDUCTION SYSTEM”.

Place the pot on the required cooking zone before switching the hob on.

Installation

After unpacking the product, check for any damage during transport. In case of problems, contact the dealer or Whirlpool Customer Service.

PREPARING THE CABINET FOR FITTING

- Install a separator panel under the hob.
- The lower part of the product must not be accessible after installation.
- In case of installation of an hob oven, do not interpose the separator panel.

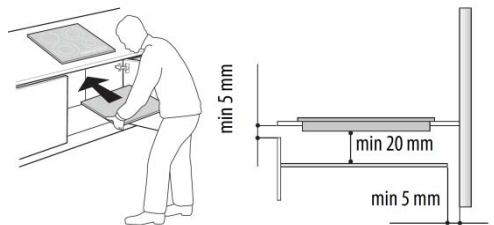

- The distance between the underside of the appliance and the separator panel must respect the dimensions given in the figure.
- In order to ensure the correct operation of the product, do not obstruct the minimum required clearance between the hob and the top of the unit (min. 5 mm).
- If an oven is installed beneath the hob, make sure the oven is equipped with a cooling system.
- Do not install the hob above a dishwasher or washing-machine, so that the electronic circuits do not come into contact with steam or moisture which could damage them.
- To remove the hob from the worktop use a screw driver (not supplied) unlocking the screws from the bottom side of the appliance.

PRODUCT OVERVIEW

Top View

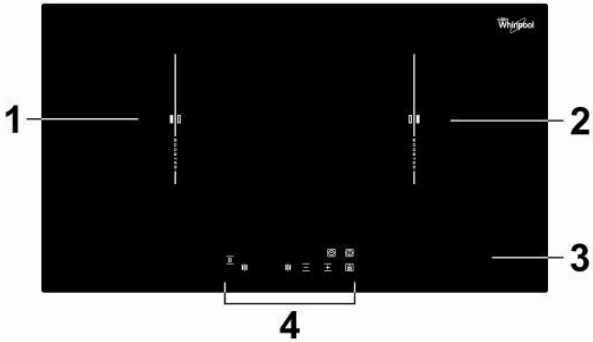

- 1. No.1 zone / The left zone
- 2. No.2 zone / The right zone
- 3. Glass plate
- 4. Control panel

Control Panel

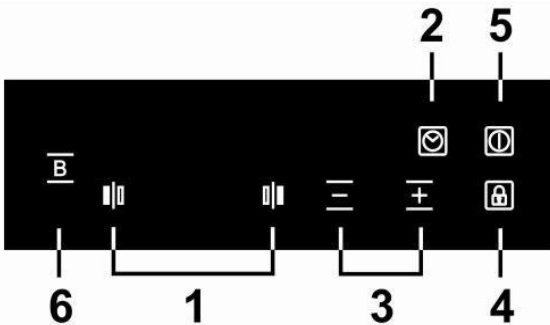

- 1. Heating zone selection
- 2. Timer
- 3. Power / Timer control
- 4. Key lock
- 5. ON/OFF
- 6. Booster function

Front View with Descriptions

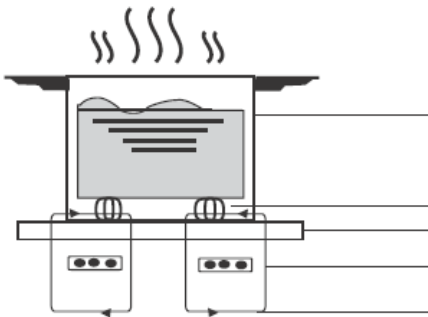

Cooking Pot

Magnetic Circuit

Ceramic Glass Plate

Induction Coil

Induced Currents

BEFORE USING YOUR NEW INDUCTION HOB

Read this guide, taking special note of the 'IMPORTANT SAFETY INSTRUCTIONS' section.

Remove all packaging, protective film and securing tape from the appliance before use.

Using The Touch Controls

- The controls respond to touch, so you don't need to apply any pressure.
- Use the ball of your finger, not its tip to control the induction hobs.
- You will hear a beep each step you operate the hob.
- Make sure the controls are always clean, dry, and that there is no object (e.g. a utensil or a cloth) covering it. Even a drop of water may make the controls difficult to operate.

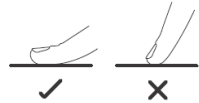

Choosing The Right Cookware

- Only use cookware with a base suitable for induction cooking. Look for the induction symbol on the packaging or on the bottom of the pan.
- You can check whether your cookware is suitable by carrying out a magnet test. Move a magnet towards the base of the pan. If it is attracted, the pan is suitable for induction.
- If you do not have a magnet:
 1. Put some water in the pan you want to check.
 2. If  does not flash in the display and the water is heating, the pan is suitable.
- Cookware made from the following materials is not suitable: pure stainless steel, aluminum or copper without a magnetic base, glass, wood, porcelain, ceramic, and earthenware.
- Do not use cookware with jagged edges or a curved base.

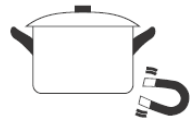

- Make sure that the base of your pan is smooth, sits flat against the glass, and is the same size as the cooking zone or at least cover 80% of the cooking zone. Use pans whose diameter is as large as the graphic of the zone selected. Using a pot a slightly wider energy will be used at its maximum efficiency. If you use smaller pot efficiency could be less than expected. Pot less than 140 mm could be undetected by the hob. Always centre your pan on the cooking zone.

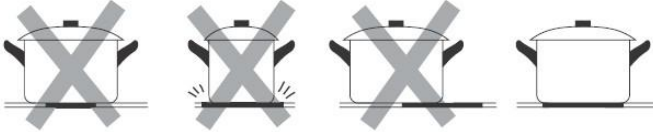

- Always lift pans off the Induction hob - do not slide, or they may scratch the glass.

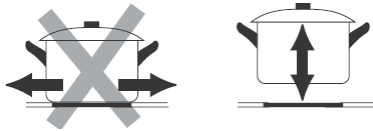

USING YOUR INDUCTION HOB

To Start Cooking

1. Touch the ON/OFF control.

After power on, the buzzer beeps once, all displays show “ - ”, indicating that the induction hob is at standby mode.





2. Place a suitable pan on the cooking zone.

Make sure the bottom of the pan and the surface of the cooking zone are clean and dry.



3. Touch the heating zone selection control, it will show  next to the key and flash.



4. Choose the power level by touching “  ” or “  ”

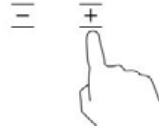

to adjust the different power from power level “1” to power level “ 9 ”.

If the display  flashes alternately with the heat setting

This means that:

- you have not placed a pan on the correct cooking zone or,
- the pan you’re using is not suitable for induction cooking or,
- the pan is too small or not properly centered on the cooking zone.



Hob cannot be started unless a suitable pan is used.

The display will automatically turn off after 1 minute if correct pan is not detected.

When You Have Finished Cooking

1. Select the heating zone control that you want to switch off.



2. Turn the cooking zone off by touching the “  ” or “  ” to reach power level “ 0 ”.



Make sure the power display shows “ 0 ”, then shows “ H ”



3. Turn off the hob by touching the “ ON/OFF ” control.



4. Residual Heat Indicator. 

Residual heat indicator “ H ” will show to alert user when cooking zones are still hot. It will disappear when the surface has cooled down to a safe temperature. It can also be used as an energy saving function if you want to heat more pans, keep a dish warm or to melt butter.

Child Lock

- You can lock the controls to prevent accidental switching on .
- When the controls are locked, all the controls are disabled except the ON/OFF control.

To activate the control panel lock functions

Touch the keylock  control. The timer indicator will show “ Lo ”. The control panel is locked.

To deactivate the control lock

1. Make sure the induction hob is turned on.
2. Touch and hold the keylock  control for 3 seconds. The hob is active again.



When the hob is locked all the controls are disabled except the ON/OFF control  , you can always turn the induction hob off with the

ON/OFF control  in an emergency, but you shall unlock the hob first in the next operation.

Over - Temperature Protection

A temperature sensor equipped can monitor the temperature inside the induction hob. When the hob is overheat, it will stop operation automatically.

Pan Detecting Function

When an unsuitable size or non-magnetic pan (e.g. aluminium), or small item (e.g. knife, fork, key) has been left on the hob, the hob automatically go on to standby in 1 minute. The fan will keep cooling down the induction hob for 1 minute.

Auto Shutdown Protection

Auto shut down is a safety protection function for your induction hob. It shut down automatically after using a period of time for safety protection. The default working times for each power levels are shown in the below table:

Power level	1	2	3	4	5	6	7	8	9
Default working timer (hour)	8	8	8	4	4	4	2	2	2

When the pot is removed, the induction hob will stop heating immediately and the hob automatically switch off after 2 minutes.



People with a heart pace maker should consult with their doctor before using this unit.

Using The Booster Function

1. Booster function can increase power and shorten the cooking time. It lasts for 10 minutes.

Using the Booster to get a larger power

1. Select the zone that you want to use by touching the heating zone selection button , an indicator next to the key will flash.

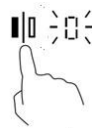

2. Touch the booster button to activate the booster function. The power display will show “ P ” to indicate that the zone is boosting.

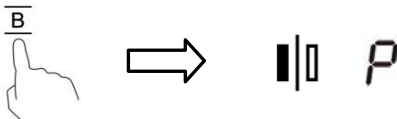

3. The booster power will last for 10 minutes and then the zone will go back to the power stage which was set before turning on booster function.



4. If you want to cancel booster function, touch the heating zone selection button first, an indicator next to the key will flash. And then touch the booster button. The heating zone will go back to the power stage which was set before turning on booster function.

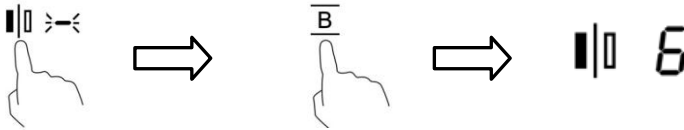

Using The Timer

You can use the timer in two different ways:

- You can use it as a minute minder. In this case, the timer will not turn any cooking zone off when the set time is up.
- You can set it to turn one cooking zone off after the set time is up.
- You can set the timer up to 99 minute.

A. Using The Timer as a Minute Minder

Note: you can use the minute minder if you're not selecting any cooking zone.



1. Make sure the hob is turned on.



2. Touch timer control, the time indicator will flash and " 30 " will show in the timer display.

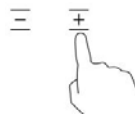

3. Set the time by touching the " + " or " - " control.



Hints: Touch the  or  control once to decrease or increase by 1 minute.

Touch and hold the  or  control of the timer to decrease or increase by 10 minutes.

4. When the time is set, it will begin to count down. The display will show the remaining time and the timer indicator will flash for 5 seconds.

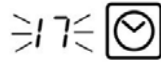

5. Buzzer will beep for 30seconds and the timer indicator shows " - - " when the set time finished.

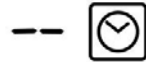



B. Setting The Timer To Turn Once Cooking Zone OFF

1. Touch the heating zone selection control that you want to set the timer for.



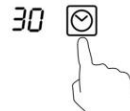



2. Touch the timer control, the timer indicator will flash and " 30 " will show in the timer display.

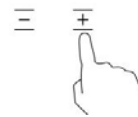

3. Set the timer by touching the  or  control.



Hints: Touch the  or  control once to decrease or increase by 1 minute.

Touch and hold the  or  control of the timer to decrease or increase by 10 minutes.

If the setting time exceeds 99 minutes, the timer will automatically return to 0 minute.

4. When the time is set, it will begin to count down. The display will show the remaining time and timer indicator flash for 5 seconds.

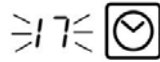

NOTE: The red dot next to power level indicator will turn on indicating that zone is selected.

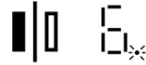

5. To cancel the timer, touch the heating zone selection control, and then touch the “ Timer ”, and the “ -- ” will show in the minute display, or “ H ” will show in the minute display and then show “ -- ”



6. When cooking time expires, the corresponding cooking zone will switch off automatically. Buzzer will beep once and the timer indicator shows “ -- ”

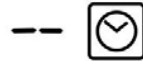

Other cooking zone will keep operating if they are turned on previously.

C. Setting The Timer To Turn More Than ONE Cooking Zone OFF

1. The timer indicator will show the shortest time if using this function (e.g. zone no.1 was set to be turned off in 6 minutes and zone no. 2 was set to be turned off in 3 minutes, the timer will show“ 3 ”.)

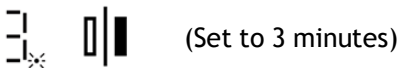
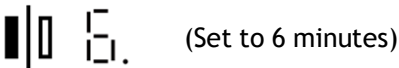

NOTE: The red dot next to the power level indicator flashes indicate it is showing cooking time of the heating zone.

If you want to check the set time of other heating zone, touch the heating zone selection control. The timer will indicate its set time.

2. When cooking time expires, the corresponding heating zone will be switched off automatically.

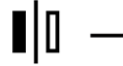

NOTE: If you want to change the time after the timer is set, you have to start from step 1.

POWER SETTINGS

The settings below are guidelines only. The exact setting will depend on your cookware and your cooking portion.

Power Setting	Suitability
1 - 2	<ul style="list-style-type: none"> • Warming for small amounts of food • Melting chocolate, butter, and foods that burn quickly • Simmering
3 - 4	<ul style="list-style-type: none"> • Reheat • Rapid simmering • Cook rice
5 - 6	<ul style="list-style-type: none"> • Pancakes
7 - 8	<ul style="list-style-type: none"> • Sauté • Cookpasta
9	<ul style="list-style-type: none"> • Stir-fry • Sear • Boil water or soup

CARE AND CLEANING

What?	How?	Important!
<p>Everyday soiling on glass (fingerprints, marks, stains left by food or non-sugary spillovers on the glass)</p>	<ol style="list-style-type: none"> 1. Switch off the hob. 2. Apply a hob or glass cleaner while the glass is still warm (but not hot!) 3. Rinse and wipe dry with a clean cloth or paper towel. 	<ul style="list-style-type: none"> ● When the hob's power is switched off, the residual heat indicator will not work but the cooking zone may still be hot! Take extreme care. ● Do not use abrasive sponges or scouring pads. Their use could eventually ruin the glass. ● After each use, clean the hob (when it is cool) to remove any deposits and stains due to food residuals ● Sugar or foods with high sugar content damage the hob and must be immediately removed. ● Salt, sugar and sand could scratch the glass surface. ● Use a soft cloth, absorbent kitchen paper or a specific hob cleaner (follow the Manufacturer's instructions).
<p>Boil overs, melts, and hot sugary spills on the glass</p>	<p>Remove it immediately with a razor blade scraper suitable for induction glass, but beware of hot cooking zone surfaces:</p> <ol style="list-style-type: none"> 1. Switch off the hob. 2. Hold the blade or utensil at a 30° angle and scrape the soiling or spill to a cool area of the hob. 3. Clean the soiling or spill up with a dish cloth or paper towel. 4. Follow steps 2 to 4 for 'Everyday soiling on glass' above. 	<ul style="list-style-type: none"> ● Remove stains left by melts and sugary food or spillovers as soon as possible. If left to cool on the glass, they may be difficult to remove or even permanently damage the glass surface. ● Cut hazard: when the safety cover is retracted, the blade in a scraper is razor-sharp. Use with extreme care and always store safety and out of reach of children.
<p>Spillovers on the touch controls</p>	<ol style="list-style-type: none"> 1. Switch the power to the hob off. 2. Soak up the spill 3. Wipe the touch control area with a clean damp sponge or cloth. 4. Wipe the area completely dry with a paper towel. 	<ul style="list-style-type: none"> ● The hob may beep and turn off by itself, and the touch controls may not function while there is liquid on it. ● Make sure you wipe the touch control area dry before turning the hob back on.

HINTS AND TIPS

Problem	Possible Causes	What To Do
The induction hob cannot be turned on.	No power supply.	Make sure the induction hob is connected to the power supply and that it is switched on. Check whether there is a power outage in your home or area. If you've checked everything and the problem persists, call a qualified technician.
The touch controls are unresponsive.	The controls are locked.	Unlock the controls. See section 'Using Your Induction Hob' for instructions.
The touch controls are difficult to operate.	There may be a slight film of water over the controls or you may be using the tip of your finger when touching the controls.	Make sure the touch control area is dry and use the ball of your finger when touching the controls.
The glass is being scratched.	Rough-edged cookware. Unsuitable, abrasive scourer or cleaning products being used.	Use cookware with flat and smooth bases. See 'Choosing The Right Cookware'. See 'Care and cleaning'.
Some pans make crackling or clicking noises.	This may be caused by the construction of your cookware (layers of different metals vibrating differently).	This is normal for cookware and does not indicate a fault.
The induction hob makes a low humming noise when used on high heat setting.	This is caused by the technology of induction cooking.	This is normal, but the noise should quieten down or disappear completely when you decrease the heat setting.
Fan noise coming from the induction hob.	A cooling fan is built into induction hob to prevent overheat. It continues to run after the hob is switched off.	This is normal. Do not disconnect the hob while the fan is running.

<p>Pans do not become hot and appears in the display.</p>	<p>The induction hob cannot detect the pan because it is not suitable for induction cooking.</p> <p>The induction hob cannot detect the pan because its size is too small for the cooking zone or not properly centered on it.</p>	<p>Use cookware suitable for induction cooking. See section 'Choosing The Right Cookware'. Centre the pan and make sure that its base matches the size of the cooking zone.</p>
<p>The induction hob or a cooking zone has turned itself off unexpectedly, a tone sounds and an error code is displayed (typically alternating with one or two digits in the cooking timer display).</p>	<p>Technical fault.</p>	<p>Please note down the error code, switch off the hob and call customer service.</p>

TROUBLESHOOTING GUIDE

Problem	Possible Causes	What To Do
F3/F4	Temperature sensor of the induction coil failure.	Please contact the supplier.
F9/FA	Temperature sensor of the IGBT failure.	Please contact the supplier.
E1/E2	Abnormal supply voltage.	Please make sure that hob is connected correctly according to the power marked on rating plate. If it is connected correctly, please make sure that power supply is working properly.
E3	High temperature of the induction coil temperature sensor.	Please confirm whether your hob has been working for a long time or the pot has run dry. If so, please restart your hob after it is cooled down.
E5	High temperature of the IGBT temperature sensor.	Please restart after the hob cools down.

TECHINCAL SPECIFICATION

Model	ACM320/BA
Cooking Zones	2 Zones
Supply Voltage, Frequency	220-240V~ , 50/60Hz
Rating Power	3800-4800W
Product Size L×W×H	700*400*40mm
Cut-out size A×B	680*380mm

INSTALLATION

This induction hob can be used as freestanding hob or built-in hob.

A. Use as Freestanding Hob

If you use it as freestanding hob, you need to install four plastic feet to the back of bottom case.

1. 4 plastic foot and screws are supplied with the hob.
2. Use a screwdriver to tighten four screws holes of plastic feet on the bottom case.
(See below picture)

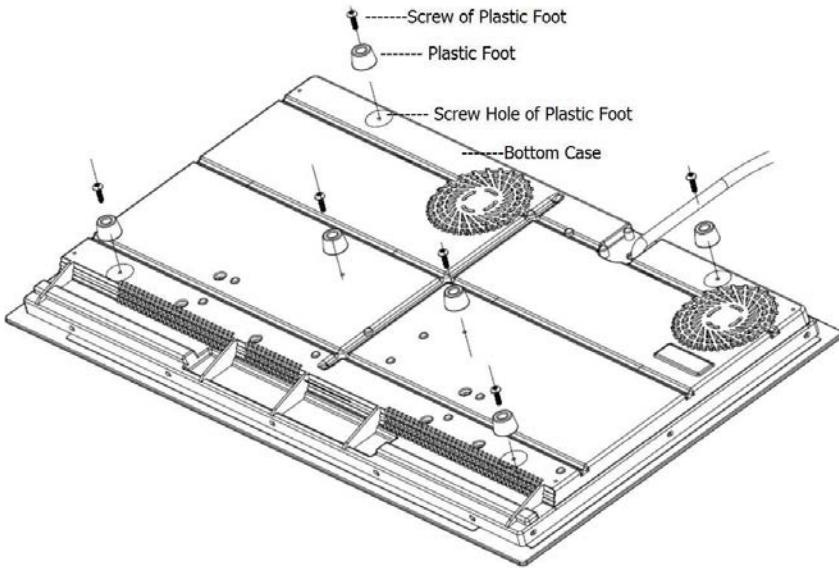

B. Use as Built-in Hob

If you use it as Built-in Hob, you don't need to install plastic feet.

1. Cut out the work surface according to the sizes shown in the drawing. For the purpose of installation and use, a minimum of 50mm space shall be preserved around the hole.

Be sure the thickness of the work surface is 12 to 42mm. Please select heat-resistant work surface material to avoid deformation caused by the heat radiation from the hotplate. As shown below:

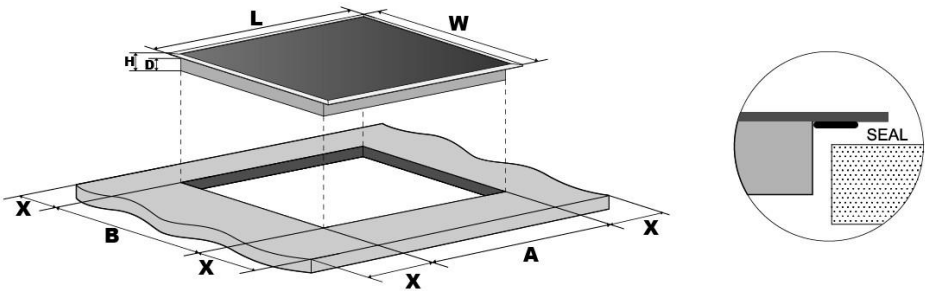

L(mm)	W(mm)	H(mm)	D(mm)	A(mm)	B(mm)	X(mm)
700	400	40	36	680	380	50 mini

Under any circumstances, make sure the induction cooker hob is well ventilated and the air inlet and outlet are not blocked. Ensure the induction cooker hob is in good work state as shown below.



Note: The safety distance between the hotplate and the cupboard above the hotplate should be at least 760mm.

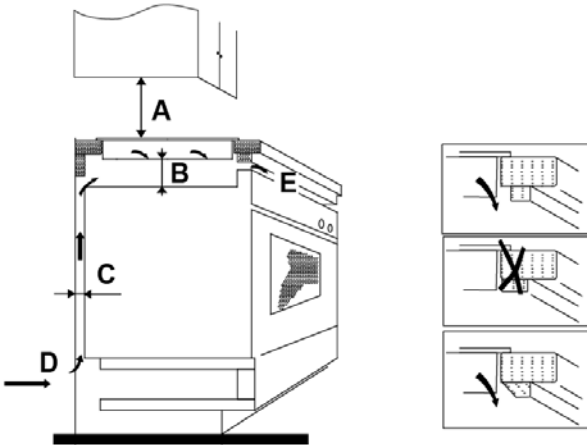

A(mm)	B(mm)	C(mm)	D	E
760	50 mini	20 mini	Air intake	Air exit 5mm

Before Locating The Fixing Brackets

The unit should be placed on a stable, smooth surface. Do not apply force onto the controls protruding from the hob.

Fix the hob on the work surface by screw four brackets on the bottom of hob (see picture) after installation.

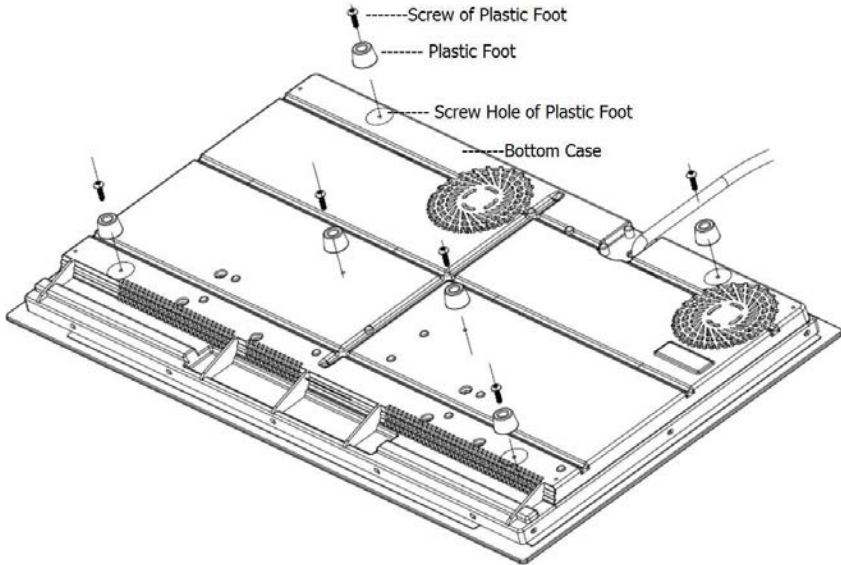

The fixing brackets can be used in two different ways. If thickness of the table "H" $\leq 23\text{mm}$, it can be used as image A. If "H" $\leq 42\text{mm}$, it can be used as image B. If "H" $> 42\text{mm}$, then it cannot be used. Adjust the bracket position to suit for different table's thickness.

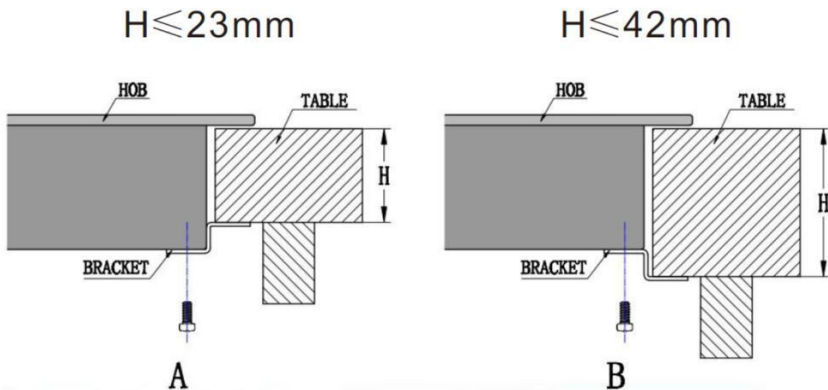

Before you install the hob, make sure that

- The work surface is level the work surface is made of a heat-resistant material.
- If the hob is installed above an oven, the oven has a built-in cooling fan the installation will comply with all clearance requirements and applicable standards and regulations.
- A suitable isolating switch providing full disconnection from the mains power supply is incorporated in the permanent wiring mounted and positioned to comply with the local wiring rules and regulations.
- The isolating switch must be of an approved type and provide a 3 mm air gap contact separation in all poles (or in all active [phase] conductors if the local wiring rules allow for this variation of the requirements).
- The isolating switch will be easily accessible to the customer with the hob installed.
- All installation must be performed by qualified technician eat-resistant material must be used for the wall or surfaces surrounding the hob.

When you have installed the hob, make sure that

- The power supply cable is not accessible through cupboard doors or drawers.
- There is adequate flow of fresh air from outside the cabinetry to the base of the hob.
- If the hob is installed above a drawer or cupboard space, a thermal protection barrier is installed below the base of the hob.
- The isolating switch is easily accessible by the customer.

CONNECTING THE HOB TO THE MAINS POWER SUPPLY



The hob must be connected to the mains power supply only by a suitable qualified person. Before connecting the hob to the mains power supply, check that:

1. The voltage corresponds to the value given in the rating plate.
2. The power supply cable sections can withstand the load specified on the rating plate.
3. To connect the hob to the mains power supply, do not use adapters, and extended cord.
4. The power supply cable must not touch any hot parts and must be positioned so that its temperature will not exceed 75°C at any point.



Check with an electrician whether the domestic wiring system is suitable without alterations.



DISPOSAL: Do not dispose this product as unsorted municipal waste. Collection of such waste separately for special treatment is necessary.

This appliance is labeled in compliance with European directive 2012/19/EU for Waste Electrical and Electronic Equipment (WEEE). By ensuring that this appliance is disposed of correctly, you will help prevent any possible damage to the environment and to human health, which might otherwise be caused if it were disposed of in the wrong way.

The symbol on the product indicates that it may not be treated as normal household waste. It should be taken to a collection point for the recycling of electrical and electronic goods.

This appliance requires specialist waste disposal. For further information regarding the treatment, recovery and recycling of this product please contact your local council, your household waste disposal service, or the shop where you purchased it.

For more detailed information about treatment, recovery and recycling of this product, please contact your local city office, your household waste disposal service or the shop where you purchased the product.

