

CS2320

**Freestanding Combi Steamer
Instruction Manual**

座檯式蒸焗爐使用手冊

目錄

■ 使用前的準備與須知

頁

重要安全資訊	2
首次使用前須知	2
使用注意及建議事項	2-3
產品放置事項	3
接地說明	3
產品及配件結構圖	4-5
控制面板	6
控制面板 - 基本功能說明	7
控制面板 - 特別功能說明	8
控制面板 - 主要功能介紹	8
控制面板 - 主要功能詳細說明	9-10
使用及烹調小貼士	11
建議烹調食譜	12

■ 操作方法說明

頁

設置時鐘	13
蒸氣模式	14
加強熱風對流模式	15
頂部 / 底部 / 上下燒烤模式	16
熱風對流模式	17
熱風模式	18
熱風加蒸氣模式	19
全功能蒸焗模式	20
發酵模式	21
翻熱麵包模式	22
慢煮模式	23
乾果模式	24
解凍模式	25
預熱模式	26-27
消毒模式	28
保溫模式	29
烘乾爐腔模式	30
除垢模式	31-32
預約功能	33-34
烹調過程中調校 / 結束後追加時間功能	35-36
餘溫高溫提示	37
童鎖功能	37

■ 清潔及保養

頁

清潔及保養	38
如何拆下爐腔內隔熱罩	39
如何拆下上發熱管	40

■ 其他須知

頁

故障排解	41-42
產品規格	43

使用前的準備與須知

■ 重要安全資訊

本說明包含有關產品安全、使用、維護及保養的重要資訊，請仔細閱讀本說明書，並將本說明書存放於容易提取的地方，以備將來查閱。

■ 首次使用前須知

1. 此產品很重，需要兩個人或以上安裝或移動此產品，必須將產品放置在堅固及平穩的表面，否則會造成身體傷害或產品損壞。
2. 此產品只設計作室內和家庭用途。請依照說明書內列明的煮食方法使用。切勿使用此產品作戶外、商業或其它用途。
3. 請確保家中使用的電壓與產品標籤上的電壓一致。
4. 產品送抵後請確保產品沒有損壞。如產品出現下列情況，請勿操作本產品：例如電源線或插頭受損、產品無法正常操作、產品受損或曾墜落。如果出現任何損壞，請聯絡惠而浦客戶服務部。
5. 切勿把電源線或插頭浸入水中，並避免電源線接觸高溫的表面，以免發生觸電，火災或其他意外。
6. 此座檯式蒸焗爐只設計作座檯式使用，不可以作嵌入式安裝。
7. 產品的四周必須保留足夠的通風空間，切勿在爐頂放置任何物件並與頂部壁櫃距離至少 5 厘米；兩旁應與牆壁距離至少 1 厘米。
8. 請勿阻擋或堵塞蒸焗爐的散熱通風口，以免對蒸焗爐造成損壞。
9. 在使用蒸焗爐前，以「消毒模式」進行 30 分鐘的消毒清潔。
10. 生產商不承擔一切由於客戶不正確使用本產品而產生的問題。
11. 前排氣出風口會有低溫蒸氣排出，切勿遮蓋前排氣出風口，以免損壞蒸焗爐。
12. 應使用耐高溫容器進行烹調，如耐熱性玻璃、耐熱性塑料容器等。所有非耐熱性容器都不應放進蒸焗爐使用。蒸焗容器耐熱溫度應高於 120°C，而烤焗容器耐熱溫度應高於 250°C。
13. 第一次使用各種燒烤或烤焗的功能時，可能會產生氣味，這是正常現象。

■ 使用注意及建議事項

1. 如發現爐門或爐門密封邊損壞時，請停止使用產品並儘快聯絡惠而浦客戶服務部。
2. 如電源線何損壞，必須由供應商 / 製造商或合格技術人員更換，以免造成危險。
3. 請勿於此爐附近加熱或使用易燃物品，以免產生火警或爆炸。
4. 切勿使用本產品烘乾布料、紙張、香料、藥材、木材、花朵或其他易燃的物件，否則可能會造成火災。
5. 切勿過度烹調食物，否則可能引致火災。
6. 使用蒸焗爐時切勿離開，尤其正當在使用紙、塑膠或其他易燃材料的物件進行烹調。當用作為食物加熱時，紙張可能會著火或燒焦，某些塑料則可能溶化。如發現有物件在蒸焗爐內或外被點燃或冒煙，請將爐門關上並關掉蒸焗爐。同時拔掉電源線並將裝設有漏電斷路器的插座電源切斷。
7. 切勿在爐內使用腐蝕性化學品或氣體。此蒸焗爐專為加熱食物或烹煮食物而設計，並不適合工業或實驗用途。
8. 此產品並非設計給身體，感官或精神上能力不足，或經驗及知識不足的人士使用（包括兒童），除非監護其安全的負責人監督或指引其使用。
9. 每次完成烹調並待蒸焗爐冷卻後，請抹走可能凝固於爐腔內的殘留物。爐腔頂部最容易出現燒焦情況，應將爐腔頂部擦洗乾淨。為確保食物得到最佳烹調效果，於每次使用後，請保持爐腔完全乾透。
10. 從蒸焗爐內提取食物及器皿時，應使用隔熱手套，以免燙傷。
11. 當蒸焗爐運作時，請避免接觸爐腔內的發熱管，以免造成危險。
12. 切勿將爐腔作存放物件之用。
13. 奶樽或嬰兒食物器皿中的食物或飲料加熱後，請務必在餵食前將食物或飲料加以攪拌，並檢查食物的溫度，確保熱力分佈均勻，以避免燙傷或灼傷嬰兒。
14. 當完成蒸或烤焗煮食模式後，應等待 10-15 分鐘才進行其他烹調模式。
15. 剛完成烤焗煮食後或爐腔處於高溫狀態下，使用蒸氣相關模式，爐腔內的蒸氣可能會迅速蒸發，蒸氣不易被看到。這是正常現象。
16. 當使用蒸焗爐時，切勿用手觸摸爐門、爐窗及外框。
17. 請使用直接從水喉取的自來水、食用水或蒸餾水注入儲

使用前的準備與須知

水箱，直至水位達到標註“MAX”（最高水位）的位置。把儲水箱完整推進於凹位內，直至聽到「卡」一聲，確保固定到位。

18. 水箱出現裂紋或缺口時，請勿繼續使用，以免引起因漏水而導致的漏電或觸電。
19. 為確保衛生，並防止冷凝水在蒸爐內積聚，請於每次使用後清空水箱及確保爐腔完全乾透。
20. 除清水外，切勿使用儲水箱盛載其他液體（除垢劑除外）。
21. 以蒸氣模式烹調過程中儘量不要打開爐門，以免蒸氣流失和爐腔溫度下降，影響烹調效果。如有需要打開爐門，請酌量增加蒸煮時間。
22. 烹調過程中如需翻轉食物或因其它需要必須打開爐門時，請盡量不要靠近爐門（特別是臉部），以免燙傷。
23. 維修操作必須由專業人員進行。除專業人員外，任何維修操作均可能帶來危險。請勿擅自對產品進行拆卸、修理或改造。
24. 產品操作時，可接觸部份的溫度可能較高，切勿讓兒童靠近。
25. 通電後，切勿以濕手或其他身體部份接觸本產品、產品之電源線或插頭，以免發生危險。
26. 切勿放置或懸掛任何物件於爐門或門上的把手，以免影響門的開關及損壞門鉸。
27. 烹調結束後，電動風扇會繼續工作一段時間，以冷卻爐腔和電子零件，屬於正常現象。
28. 如未能妥善清潔產品及其配件，會導致器具表面劣化，這會影響器具的壽命，可能會導致危險的情況。
29. 清潔前請切斷電源，不可使用具有腐蝕性的清潔劑，以免損壞或腐蝕本產品。
30. 在除垢模式時，水箱的水會被加熱，並流到接水盤內，請勿讓兒童接觸或走近。
31. 在清潔爐腔時，請切斷電源，如需要清潔風扇，請小心除去爐腔內隔熱罩，以及按照指示裝回，方可再次使用。（詳情參照說明書內“如何拆下爐腔內隔熱罩”）
32. 請定期清除電源插頭上的灰塵。長期不使用時，請拔出電源插頭。拔除電源插頭時不要拉扯電線，應手握插頭拔除。
33. 請不要讓蒸焗爐處於無人監看的狀態下工作。
34. 過熱的脂肪和油很容易著火。除了烤肉，在烹調過程中對油進行加熱也是很危險的，應禁止這樣操作。

35. 爐門負重不可超過 7 公斤，為避免損害蒸焗爐，請勿把食物或任何重物放在爐門上。

■ 產品放置事項

1. 產品的四周必須有足夠的通風空間，切勿在爐頂放置任何物件並與頂部壁櫃距離至少 5 厘米；兩旁應與牆壁距離至少 1 厘米；機背可貼近牆壁。

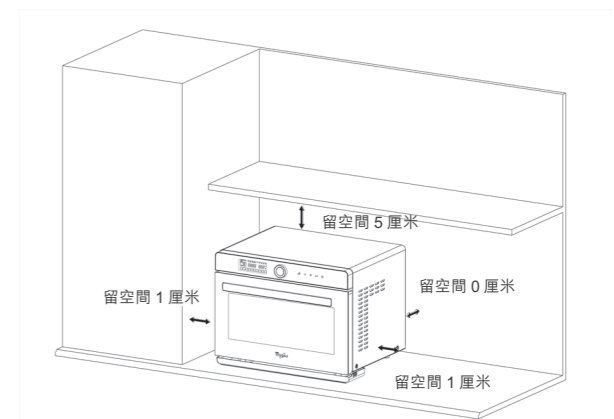

2. 請勿堵塞出風口，入氣口，否則可能造成火災。請經常保養，避免垃圾、灰塵等堵塞出風口，入氣口。
3. 不可將產品放置於高溫潮濕地方。例如煤氣爐，帶電區或水槽旁邊等。
4. 產品必須平放在堅固及平穩的表面。

■ 接地說明

本產品必須接地使用。萬一漏電，接地可以提供電流回路以避免觸電。本產品提供的接地插頭必須插在單相兩極帶接地的插座上。

■ 產品及配件結構圖

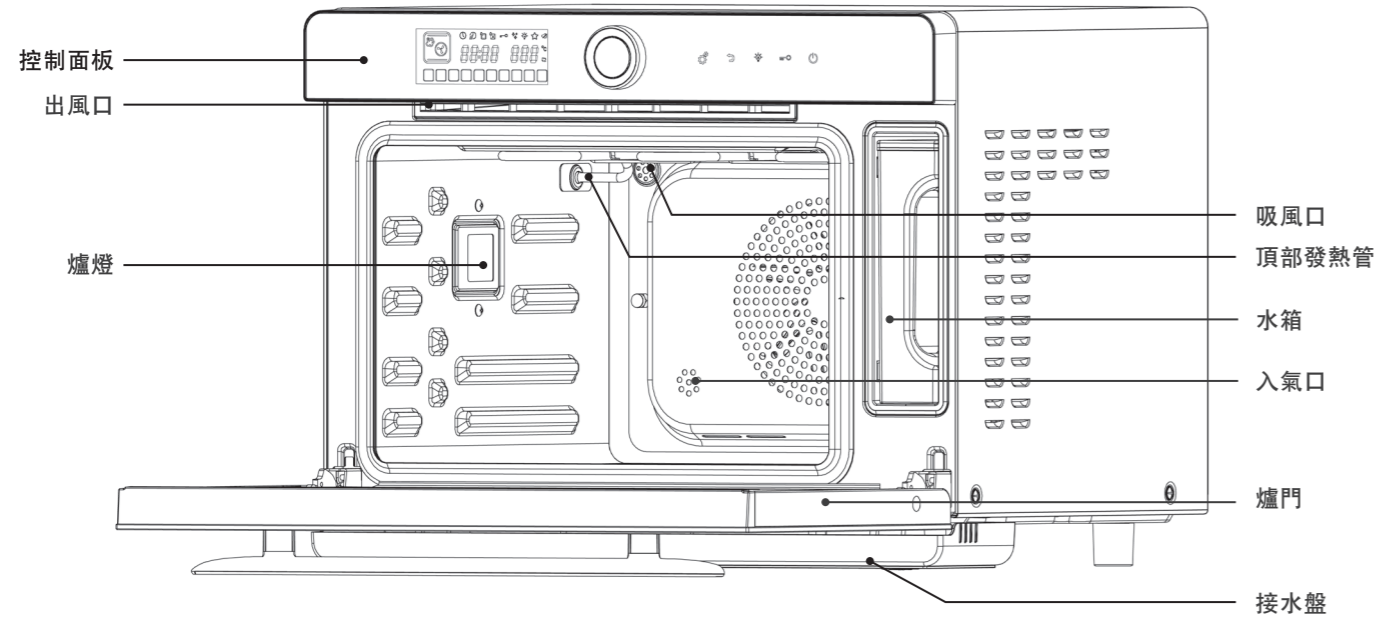

1. **控制面板**: 用於操作蒸焗爐 (詳細請參考控制面板說明 P.6-10)
2. **出風口**: 排出爐內多餘的熱氣及水蒸氣。
3. **爐燈**: 爐腔照明, 以便觀察烹調的食物。
4. **吸風口**: 爐腔內多餘的蒸氣及熱氣由此孔抽到出風口。
5. **頂部發熱管**: 產生熱能烹調食物。
6. **水箱**: 盛載清水以產生蒸氣。
7. **入氣口**: 讓蒸氣進入爐腔內。
8. **爐門**: 1. 確保爐門關上後, 才開啟烹調程式。
2. 在烹調過程中, 將爐門打開, 烹調會暫停; 把爐門關上後, 會自動繼續原先的烹調設定。
9. **接水盤**: 盛載開門後流出的倒汗水及除垢功能中的污水。

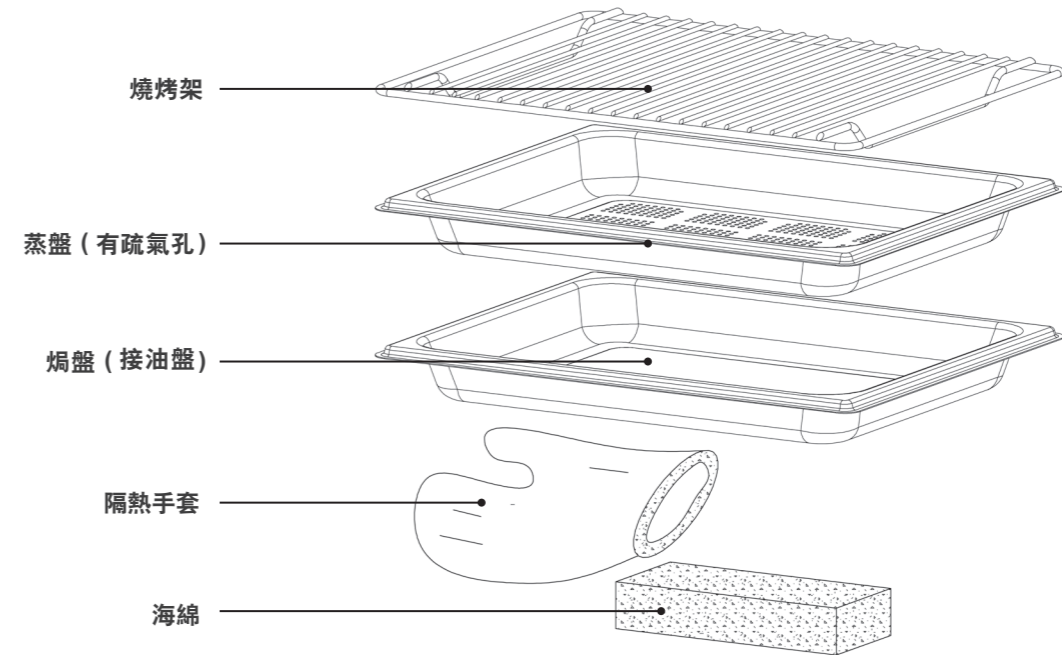

1. 燒烤架

- (A) 主要用於所有使用發熱管加热的模式, 如各個「燒烤」或「熱風對流」或「熱風」等模式使用。
- (B) 如需進行多層煮食, 建議將此燒烤架放於較底層的位置, 如進行三層煮食, 請放於最底位置。可使爐腔內空氣更流通、讓爐腔溫度更平均。
- (C) 食物無容器盛放時, 請用牛油紙或錫紙, 平鋪在燒烤架上使用。

2. 蒸盤 (有疏氣孔)

- (A) 主要用於「蒸氣」時使用。其疏氣孔設計亦可用於其他烹調模式。
- (B) 如需進行多層煮食, 建議將此蒸盤放於較底層的位置, 如進行三層煮食, 請放中間位置。可使爐腔內空氣更流通、讓爐腔溫度更平均。

3. 焗盤 (接油盤)

- (A) 主要用於「熱風加蒸氣」、「全功能蒸焗」或「熱風」等模式時使用。或於烹調肉類時放於底層, 盛載煮食中滴下來的油。
- (B) 食物無容器盛放時, 請用牛油紙或錫紙, 平鋪在焗盤上使用。

4. 隔熱手套

由蒸焗爐拿出食物或托盤時使用。

5. 海綿

用於吸取爐腔內的倒汗水。

■ 控制面板

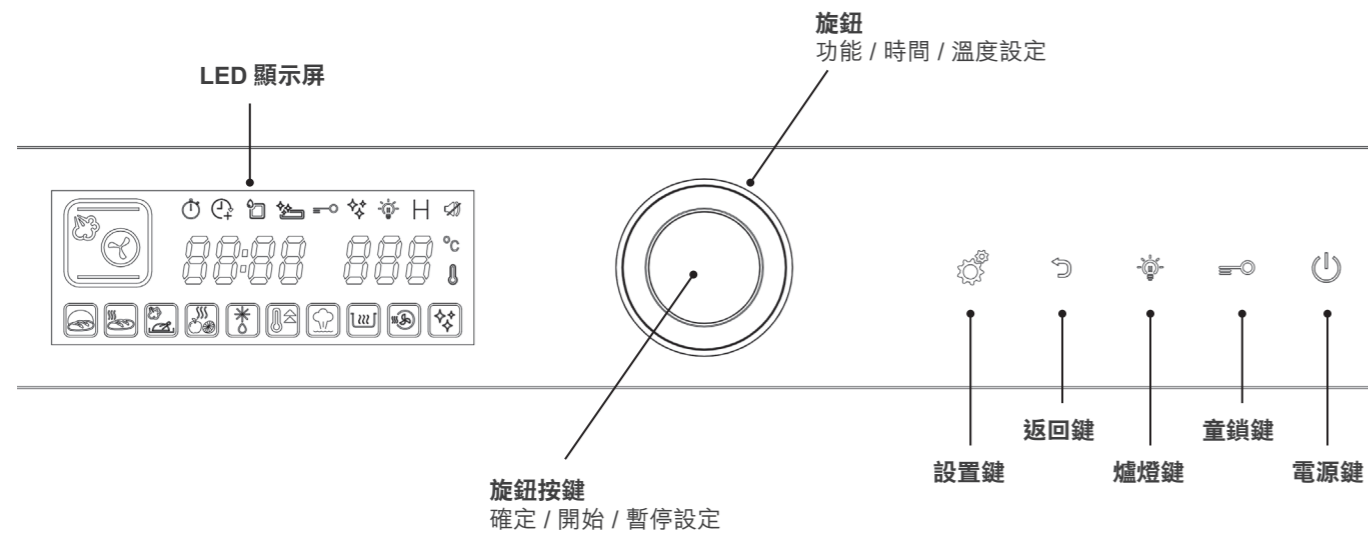

■ 控制面板 - 基本功能說明

圖示	功能說明
	<p>旋鈕 功能 / 時間 / 溫度設定</p> <p>旋鈕按鍵 確定 / 開始 / 暫停設定</p>
	<p>設置鍵</p> <ol style="list-style-type: none"> 時鐘設定：在待機狀態下長按設置鍵 3 秒鐘，即可進入設置時鐘畫面，進行時鐘設定。(詳細請參閱第 13 頁 “設置時鐘”); 預約功能設定：烹調模式、烹調時間和烹調溫度設定後，按設置鍵，即可進入預約功能畫面，進行預約設定。(詳細請參閱第 33-34 頁 “預約功能”); 在暫停狀態下，按設置鍵可重新調整烹調時間和溫度。(詳細請參閱第 35 頁 “烹調過程中調校功能”)
	<p>返回鍵</p> <ol style="list-style-type: none"> 返回 / 取消; 在設置過程中，按返回鍵可回到上一個畫面，即可重新調整烹調模式或烹調時間。 靜音模式 <p>啟動靜音模式：在待機狀態下長按返回鍵 3 秒即啟動靜音模式，顯示屏上靜音圖示亮起，按鍵音效提示關閉。</p> <p>解除靜音模式：在待機狀態下長按返回鍵 3 秒即可解除靜音模式。</p>
	<p>爐燈鍵</p> <ol style="list-style-type: none"> 輕按一次，爐燈亮 3 分鐘，顯示屏上不會顯示爐燈圖標; 長按 3 秒，爐燈長亮，顯示屏上會顯示爐燈圖標，再長按 3 秒取消長亮; 打開爐門，爐燈亮 3 分鐘。
	<p>童鎖鍵</p> <p>長按 3 秒可啟動 / 解除童鎖。</p> <p>啟動童鎖：長按童鎖鍵 3 秒啟動，控制面板會被鎖定並不能控作。</p> <p>解除童鎖：長按童鎖鍵 3 秒即可解除童鎖功能。</p>
	<p>電源鍵</p> <p>如果開啟蒸焗爐後，沒有進行任何操作，包括打開或關閉爐門，5 分鐘後，蒸焗爐將自動進入省電模式，顯示屏會熄滅。省電模式下只有電源鍵能操作。</p>

■ 控制面板 - 特別功能說明

組合鍵功能	圖示	功能說明
組合鍵： 爐腔溫度顯示		在烹調過程中，同時按【設置鍵 + 爐燈鍵】3秒，溫度顯示切換為爐腔實際溫度。如要返回設置的烹調溫度，再同時按【設置鍵 + 電源鍵】3秒即可。

■ 控制面板 - 主要功能介紹

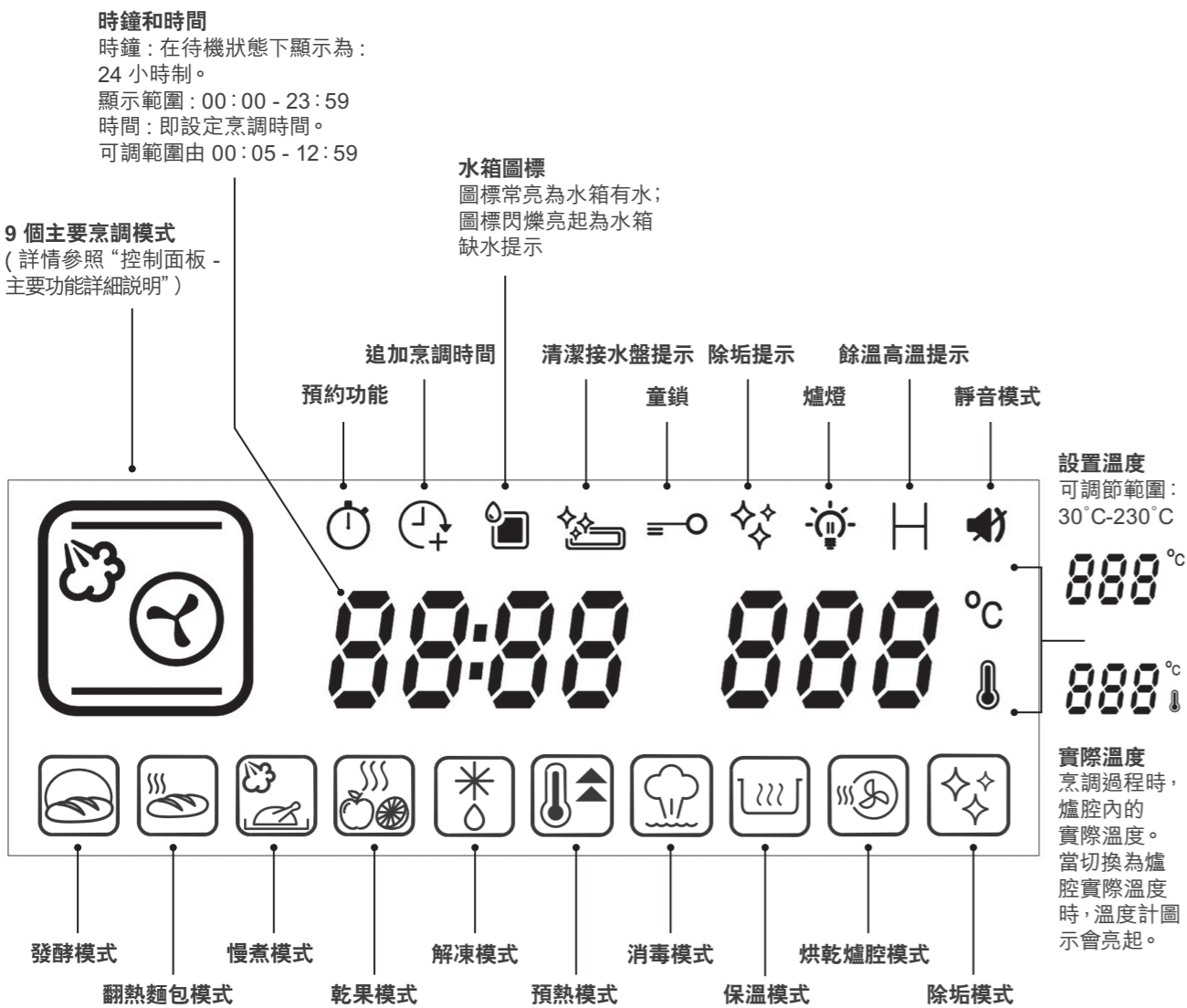

■ 控制面板 - 主要功能詳細說明

圖示	模式	功能介紹	默認時間 / 溫度	時間 / 溫度選擇範圍
	蒸氣	此模式以蒸氣烹調食物，可保留食物原有的味道，營養及顏色。適合蒸煮蔬菜，肉類，海鮮或燉湯等。	30分鐘 / 100°C	時間 5 - 419分鐘 (最長6小時59分鐘) 溫度 50 - 110°C
	加強熱風對流	以較短時間烤焗食物，加快烹調時間。適用烤焗體積較大的肉類及糕點。	30分鐘 / 180°C	時間 5 - 239分鐘 (最長3小時59分鐘) 溫度 100 - 230°C
	頂部燒烤	適合燒烤食材，或用於烤焗的最後階段，作加強食物金黃及烤色的作用。	30分鐘 / 180°C	時間 5 - 239分鐘 (最長3小時59分鐘) 溫度 100 - 230°C
	底部燒烤	適合烘焙的最後階段或局部時段只需底部加熱的食物，如薄餅或馬卡龍等菜式。熱力會從底部散發出來。	30分鐘 / 180°C	時間 5 - 239分鐘 (最長3小時59分鐘) 溫度 100 - 230°C
	上下燒烤	傳統的一層烘焙與烤焗。熱力會從上面及底部均勻地散發出來。適用於烹調肉類、魚類等食物。尤其適合頂部有濕潤配料的蛋糕。	30分鐘 / 180°C	時間 5 - 239分鐘 (最長3小時59分鐘) 溫度 100 - 230°C
	熱風對流	上下發熱線及背部風扇同時運作，用於各種烤焗菜式，如肉類、海鮮類、薄餅、麵包以及各式曲奇、糕點及甜品等。	30分鐘 / 180°C	時間 5 - 239分鐘 (最長3小時59分鐘) 溫度 100 - 230°C
	熱風	設有風扇在背部，風扇會將背部發熱線產生的熱氣，均勻的送到爐中每一個角落。使多層烤焗的食物受熱更平均。可使用於一層或以上的烤焗。	30分鐘 / 180°C	時間 5 - 239分鐘 (最長3小時59分鐘) 溫度 100 - 230°C
	熱風加蒸氣	以熱風煮食並加入蒸氣，讓烹調的食物不會因烤焗的高溫而流失水份。背部風扇使熱風均勻循環流動，可確保多層烤焗的食物受熱更平均。適用於煮各種食物。	30分鐘 / 180°C	時間 5 - 419分鐘 (最長6小時59分鐘) 溫度 100 - 230°C
	全功能蒸焗	此模式集合上下火、熱風、蒸氣功能於一身，全功能的完美結合。煮食過程中加入蒸氣，讓烹調的食物不會因烤焗而流失水份。適用於煮各種食物。例如較大的肉類或烤焗濕潤的蛋糕。	30分鐘 / 180°C	時間 5 - 419分鐘 (最長6小時59分鐘) 溫度 100 - 230°C
	發酵	此模式以蒸氣運作，使爐腔達至調校的穩定而潮濕的環境。用於麵團發酵，例如薄餅的餅底或製作麵包時的麵團。麵團發酵的速度會比在室溫下快，麵團表面也不會過乾。	30分鐘 / 35°C	時間 5 - 419分鐘 (最長6小時59分鐘) 溫度 30 - 40°C

■ 控制面板 - 主要功能詳細說明

圖示	模式	功能介紹	默認時間 / 溫度設置	時間 / 溫度選擇範圍
	翻熱麵包	此程式會以已調節的最佳溫度去翻熱麵包，過程中加入蒸氣，使效果像剛出爐的新鮮麵包。備有兩種翻熱麵包模式：室溫和冷藏麵包。	10 分鐘	時間 5 - 59 分鐘 溫度不可調校
	慢煮	以蒸氣維持爐腔的溫度。以低溫慢煮，沒有經過高溫加熱，可使各種肉類和海鮮保存原有的鮮味。需配合真空袋使用。	30 分鐘 / 60°C	時間 5 - 419 分鐘 (最長 6 小時 59 分鐘) 溫度 50 - 90°C
	乾果	以低溫熱風去風乾食物，適合製作各種生果片，蔬菜片或肉乾。	60 分鐘 / 80°C	時間 5 - 779 分鐘 (最長 12 小時 59 分鐘) 溫度 40 - 90°C
	解凍	用於解凍冷藏或冷凍食物。	30 分鐘 / 55°C	時間 5 - 419 分鐘 (最長 6 小時 59 分鐘) 溫度 50 - 60°C
	預熱 - 蒸氣	以蒸氣進行預熱。使爐腔達到預設溫度。	當前時間 / 100°C	溫度 50 - 110°C
	預熱 - 烤焗	以烤焗進行預熱。使爐腔達到預設溫度。	當前時間 / 180°C	溫度 100- 230°C
	消毒	以高溫蒸氣消毒，可消毒餐具或嬰兒奶瓶等。	30 分鐘 / 110°C	時間 5 - 419 分鐘 (最長 6 小時 59 分鐘) 溫度 110°C
	保溫	以熱風保溫食物。適合把剛煮的食物保溫。	30 分鐘 / 55°C	時間 5 - 239 分鐘 (最長 3 小時 59 分鐘) 溫度 50 - 60°C
	烘乾爐腔	此模式會以高溫加熱爐腔，蒸發爐腔中多餘的水份和蒸氣。此功能適用於任何蒸氣烹調的模式後使用。	25 分鐘	時間不可調校 溫度不可調校
	除垢	當蒸氣模式或其他帶有蒸氣功能模式使用的累計時間達到 100 個小時，“除垢提示”圖示會亮起，提醒用戶進行除垢模式。需配合除垢劑使用。	50 分鐘	時間不可調校 溫度不可調校

■ 使用及烹調小貼士

- 所有烹調模式的最短設定的時間為 5 分鐘。(除‘追加烹調時間’功能外)
- 完成烹調後，風扇會延時工作 3 分鐘，將爐腔內的熱量排出，這是正常現象。
- 烹調過程中，如果將爐門打開，蒸焗爐會自動暫停；將爐門關上，則自動啟動並按餘下設定時間及溫度繼續烹調。
- 加熱湯類、汁類或飲品等液體食物時，取出時必須小心。在烹調時，請留意以下各點：
 - 不要過度加熱。否則在取出食物時，會由於突然沸騰導致液體飛濺而燙傷。
 - 液體食物加熱時，液體不要多於容器的八成滿。因為加熱少量液體食物會由於沸騰而導致液體突然飛濺。
 - 加熱前或加熱途中請攪拌。
 - 加熱後，先讓食物在爐內放置片刻，略加攪拌後取出。
 - 使用奶瓶或加熱嬰兒食物後，即攪拌或搖動，餵食前應檢查溫度，避免燙傷。
- 如要在烹調過程中，檢查食物溫度，必須使用焗爐專用的溫度計檢查。如果食物烹調時間不足則再放入爐內繼續烹調。
- 烤焗完成後，建議立刻取出以免殘留熱量使食物過熱或使烤色變深。
- 烤焗過程中為維持爐內溫度，請儘量避免開關爐門檢查食物，以免影響爐內溫度。如於煮食過程中曾打開爐門，請相應地增加烹食時間。
- 如果擔心烤色不均勻，請在加熱途中調整或翻轉食物、蒸焗盤的位置或方向。
- 配件擺放技巧
 - 單層煮食：建議放置配件在第 3 層
 - 兩層煮食：建議放置配件在第 2 和第 4 層
 - 三層煮食：建議放置配件在第 2、第 3 和第 4 層

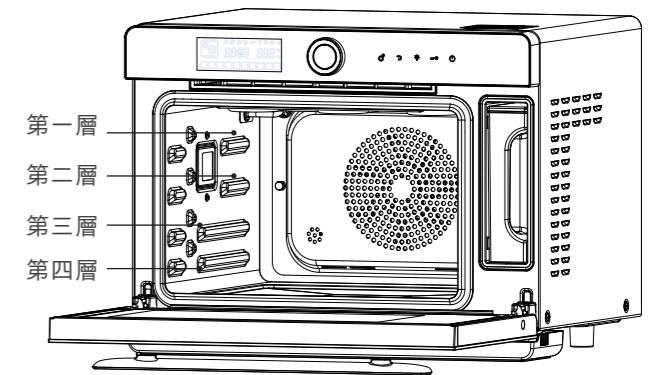

以上建議擺放層數、位置僅供參考。客人可因應食物份量、種類和存放食物的容器，去調整擺放配件的層數和位置。

■ 建議烹調食譜

菜式	份量	類別	模式	溫度	時間	預熱	使用配件	配件位置
菜芯	約半斤	蔬菜	蒸氣	110°C	5分鐘	需要	蒸盤	第3層
蒸水蛋	1隻蛋+2份水	蛋	蒸氣	100°C	9分鐘	需要	蒸盤	第3層
蒸白飯	120克米+120克水	五穀	蒸氣	100°C	25分鐘	不需要	蒸盤	第3層
猴頭菇响螺片 瘦肉燉湯	300克材料+ 1000克水	湯	蒸氣	100°C	180分鐘	不需要	蒸盤	第3層
蒸肉餅	370克	肉	蒸氣	100°C	25分鐘	需要	蒸盤	第3層
烤焗雞腿	4隻雞腿	肉	全功能蒸焗	200°C	18分鐘	需要	燒烤架/ 焗盤	第3層
肉餅煲仔飯	150克肉餅+100克米 +100克水	肉+五穀	全功能蒸焗	180°C	40分鐘	需要	燒烤架/ 焗盤	第3層
提子鬆餅	12個	麵包	加強熱風對流	180°C	22分鐘	需要	焗盤	第2層和 第4層
圓形餐包	230克	麵包	加強熱風對流	180°C	25分鐘	需要	焗盤	第3層
朱古力 布朗尼蛋糕	6個	甜品	熱風對流	180°C	20分鐘	需要	焗盤	第3層
馬卡龍	12個	甜品	底部燒烤	140°C	15分鐘	需要	焗盤	第4層
冷藏有餡麵包	1個	麵包	翻熱麵包“1”	默認	12分鐘	不需要	燒烤架/ 焗盤	第3層
室溫有餡麵包	1個	麵包	翻熱麵包“2”	默認	10分鐘	不需要	燒烤架/ 焗盤	第3層
冷藏麵包	1個	麵包	翻熱麵包“1”	默認	10分鐘	不需要	燒烤架/ 焗盤	第3層
室溫麵包	1個	麵包	翻熱麵包“2”	默認	8分鐘	不需要	燒烤架/ 焗盤	第3層

以上的建議烹調食譜僅提供參考。客人喜歡的生熟程度、開始溫度、所烹調的食物份量、大小、食物形狀和容器的種類等，都會影響烹調時間和烹調效果。

■ 設置時鐘

首次開機後，蒸焗爐發出「必」一聲後即進入待機畫面，時鐘默認顯示 12:00 (如下圖)，顯示屏全亮。



在開機後畫面後，若在 5 分鐘內沒有進行任何操作，會自動進入省電模式，此時顯示屏熄滅，省電模式下只有電源鍵能操作。省電模式下按“電源鍵”退出省電模式，機器進入開機後畫面。

例如：設置現前時間為 13 時 20 分。

操作步驟：

1. 在待機畫面下，長按設置鍵  3 秒，小時位閃爍 (如下圖)；



2. 轉動旋鈕直到顯示小時位轉至 13，按旋鈕確認。(如下圖) 然後畫面會自動跳至分鐘選項。



3. 轉動旋鈕直到顯示分鐘轉至 20，按旋鈕確認。(如下圖)



4. 完成時間設置。(如下圖)



注意：在設置過程中，若連續 5 分鐘內用戶沒有任何操作，當前所有設置將會被取消並返回到待機畫面，進入待機狀態。

操作方法說明

■ 蒸氣模式

此模式以蒸氣烹調食物，可保留食物原有的味道，營養及顏色。適合蒸煮蔬菜，肉類，海鮮或燉湯等。每次使用前，請確保水箱已加滿水。

	溫度	時間
開機預設	100°C	30 分鐘
設定範圍	50°C - 110°C	5 分鐘 - 6 小時 59 分鐘

例如：設置烹調時間為 1 小時 40 分鐘，溫度為 90°C。

操作步驟：

1. 在待機狀態下，順時針旋轉旋鈕至  蒸氣模式圖示閃爍，按旋鈕確認功能。(如下圖) 然後畫面會自動跳至小時選項。



2. 轉動旋鈕直到顯示小時位轉至 01，按旋鈕確認。(如下圖) 然後畫面會自動跳至分鐘選項。



3. 轉動旋鈕直到顯示分鐘轉至 40，按旋鈕確認。(如下圖) 然後畫面會自動跳至溫度選項。



4. 轉動旋鈕直到顯示溫度轉至 90°C，按旋鈕確認。(如下圖)



5. 設置完成，開始烹調。

操作方法說明

■ 加強熱風對流模式

以較短時間烤焗食物，加快烹調時間。適用烤焗體積較大的肉類及糕點。建議把食物放在鋪有錫紙或牛油紙的焗盤上直接烤焗。

	溫度	時間
開機預設	180°C	30 分鐘
設定範圍	100°C - 230°C	5 分鐘 - 3 小時 59 分鐘

例如：設置烹調時間為 40 分鐘，溫度為 210°C。

操作步驟：

1. 在待機狀態下，順時針旋轉旋鈕至  加強熱風對流模式圖示閃爍，按旋鈕確認功能。(如下圖) 然後畫面會自動跳至小時選項。

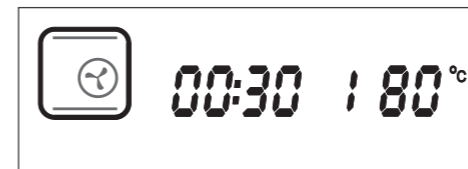

2. 按旋鈕確認小時位 00 設定。(如下圖) 然後畫面會自動跳至分鐘選項。



3. 轉動旋鈕直到顯示分鐘轉至 40，按旋鈕確認。(如下圖) 然後畫面會自動跳至溫度選項。



4. 轉動旋鈕直到顯示溫度轉至 210°C，按旋鈕確認。(如下圖)



5. 設置完成，開始烹調。

操作方法說明

■ 頂部 / 底部 / 上下燒烤模式

設有三種不同的燒烤模式，分別為頂部燒烤模式，底部燒烤模式和上下燒烤模式（頂部及底部燒烤）。可因應食材種類和所需的烹調效果去選擇合適的燒烤模式。可把食物放在鋪有錫紙或牛油紙的燒烤架或焗盤上直接烤焗。

頂部燒烤模式：適合燒烤食材或用於烤焗的最後階段，作加強食物金黃度及烤色的作用。

底部燒烤模式：適合烘焙的最後階段或局部時段只需底部加熱的食物，如薄餅或馬卡龍等菜式。熱力會從底部散發出來。

上下燒烤模式：傳統的一層烘焙與烤焗。熱力會從上面及底部均勻地散發出來。適用於烹調肉類、魚類等食物。尤其適合頂部有濕潤配料的蛋糕。

	溫度	時間
開機預設	180°C	30 分鐘
設定範圍	100°C - 230°C	5 分鐘 - 3 小時 59 分鐘

例如：設置烹調時間為 40 分鐘，溫度為 210°C。

操作步驟：

1. 在待機狀態下，順時針旋轉旋鈕至  或  或  所需燒烤模式圖示閃爍，按旋鈕確認功能。（如下圖）然後畫面會自動跳至小時選項。



2. 按旋鈕確認小時位 00 設定。（如下圖）然後畫面會自動跳至分鐘選項。



3. 轉動旋鈕直到顯示分鐘轉至 40，按旋鈕確認。（如下圖）然後畫面會自動跳至溫度選項。



4. 轉動旋鈕直到顯示溫度轉至 210°C，按旋鈕確認。（如下圖）



5. 設置完成，開始烹調。

操作方法說明

■ 熱風對流模式

上下發熱線及背部風扇同時運作，用於各種烤焗菜式，如肉類、海鮮類、薄餅、麵包以及各式曲奇、糕點及甜品等。可把食物放在鋪有錫紙或牛油紙的燒烤架或焗盤上直接烤焗。

	溫度	時間
開機預設	180°C	30 分鐘
設定範圍	100°C - 230°C	5 分鐘 - 3 小時 59 分鐘

例如：設置烹調時間為 40 分鐘，溫度為 210°C。

操作步驟：

1. 在待機狀態下，順時針旋轉旋鈕  至熱風對流模式圖示閃爍，按旋鈕確認功能。（如下圖）然後畫面會自動跳至小時選項。



2. 按旋鈕確認小時位 00 設定。（如下圖）然後畫面會自動跳至分鐘選項。



3. 轉動旋鈕直到顯示分鐘轉至 40，按旋鈕確認。（如下圖）然後畫面會自動跳至溫度選項。



4. 轉動旋鈕直到顯示溫度轉至 210°C，按旋鈕確認。（如下圖）



5. 設置完成，開始烹調。

操作方法說明

■ 熱風模式

設有風扇在背部，風扇會將背部發熱線產生的熱氣，均勻地送到爐中每一個角落。使多層烤焗的食物受熱更平均。可使用於一層或以上的烤焗。可把食物放在鋪有錫紙或牛油紙的焗盤上直接烤焗。

	溫度	時間
開機預設	180°C	30 分鐘
設定範圍	100°C - 230°C	5 分鐘 - 3 小時 59 分鐘

例如：設置烹調時間為 40 分鐘，溫度為 210°C。

操作步驟：

1. 在待機狀態下，順時針旋轉旋鈕至  熱風模式圖示閃爍，按旋鈕確認功能。(如下圖) 然後畫面會自動跳至小時選項。



2. 按旋鈕確認小時位 00 設定。(如下圖) 然後畫面會自動跳至分鐘選項。



3. 轉動旋鈕直到顯示分鐘轉至 40，按旋鈕確認。(如下圖) 然後畫面會自動跳至溫度選項。



4. 轉動旋鈕直到顯示溫度轉至 210°C，按旋鈕確認。(如下圖)



5. 設置完成，開始烹調。

操作方法說明

■ 熱風加蒸氣模式

以熱風煮食並加入蒸氣，讓烹調的食物不會因烤焗的高溫而流失水份。背部風扇使熱風均勻循環流動，可確保多層烤焗的食物受熱更平均。適用於煮各種食物。可把食物放在鋪有錫紙或牛油紙的焗盤上直接烤焗。每次使用前，請確保水箱已加滿水。

	溫度	時間
開機預設	180°C	30 分鐘
設定範圍	100°C - 230°C	5 分鐘 - 6 小時 59 分鐘

例如：設置烹調時間為 40 分鐘，溫度為 210°C。

操作步驟：

1. 在待機狀態下，順時針旋轉旋鈕至  熱風加蒸氣模式圖示閃爍，按旋鈕確認功能。(如下圖) 然後畫面會自動跳至小時選項。



2. 按旋鈕確認小時位 00 設定。(如下圖) 然後畫面會自動跳至分鐘選項。



3. 轉動旋鈕直到顯示分鐘轉至 40，按旋鈕確認。(如下圖) 然後畫面會自動跳至溫度選項。



4. 轉動旋鈕直到顯示溫度轉至 210°C，按旋鈕確認。(如下圖)



5. 設置完成，開始烹調。

操作方法說明

■ 全功能蒸焗模式

此模式集合上下火、熱風、蒸氣功能於一身，全功能的完美結合。煮食過程中加入蒸氣，讓烹調的食物不會因烤焗而流失水份。適用於煮各種食物。例如較大的肉類或烤焗濕潤的蛋糕。可把食物放在鋪有錫紙或牛油紙的焗盤上直接烤焗。每次使用前，請確保水箱已加滿水。

	溫度	時間
開機預設	180°C	30 分鐘
設定範圍	100°C - 230°C	5 分鐘 - 6 小時 59 分鐘

例如：設置烹調時間為 40 分鐘，溫度為 210°C

操作步驟：

1. 在待機狀態下，順時針旋轉旋鈕至  全功能蒸焗模式圖示閃爍，按旋鈕確認功能。(如下圖) 然後畫面會自動跳至小時選項。



2. 按旋鈕確認小時位 00 設定。(如下圖) 然後畫面會自動跳至分鐘選項。



3. 轉動旋鈕直到顯示分鐘轉至 40，按旋鈕確認。(如下圖) 然後畫面會自動跳至溫度選項。



4. 轉動旋鈕直到顯示溫度轉至 210°C，按旋鈕確認。(如下圖)



5. 設置完成，開始烹調。

操作方法說明

■ 發酵模式

此模式以蒸氣運作，使爐腔達至已調校的穩定而潮濕的環境。用於麵糰發酵：如薄餅的餅底或製作麵包的麵糰。麵糰發酵速度會較室溫下快，麵糰表面也不會過乾。每次使用前，請確保水箱已加滿水。

	溫度	時間
開機預設	35°C	30 分鐘
設定範圍	30°C - 40°C	5 分鐘 - 6 小時 59 分鐘

例如：設置烹調時間為 40 分鐘，溫度為 35°C。

操作步驟：

1. 在待機狀態下，順時針旋轉旋鈕至  發酵模式圖示閃爍，按旋鈕確認功能。(如下圖) 然後畫面會自動跳至小時選項。



2. 按旋鈕確認小時位 00 設定。(如下圖) 然後畫面會自動跳至分鐘選項。



3. 轉動旋鈕直到顯示分鐘轉至 40，按旋鈕確認。(如下圖) 然後畫面會自動跳至溫度選項。



4. 按旋鈕確認預設溫度 35°C 的設定。(如下圖)



5. 設置完成，開始烹調。(如下圖)



操作方法說明

■ 翻熱麵包模式

此程式會以已調節的最佳溫度去翻熱麵包，過程中加入蒸氣，使效果像剛出爐的新鮮麵包。備有兩種模式：室溫麵包或冷藏麵包。每次使用前，請確保水箱已加滿水。

建議烹調時間：一般冷藏麵包所需翻熱時間大約是 10-15 分鐘；室溫麵包麵包所需翻熱時間大約是 8-13 分鐘。如果有餡的麵包要再加多 5-10 分鐘。此建議烹調時間僅供參考。客人需因應麵包份量、大小、種類和個人喜好等自行調整翻熱時間。

時間	模式
開機預設	10 分鐘 “1” 冷藏麵包
設定範圍	5 分鐘 - 59 分鐘 “1” 冷藏麵包 / “2” 室溫麵包

例如：烹調從雪櫃取出的麵包，設置烹調時間為 25 分鐘。

操作步驟：

1. 在待機狀態下，順時針旋轉旋鈕至  翻熱麵包模式圖示閃爍，按旋鈕確認功能。(如下圖) 然後畫面會自動跳至分鐘選項。



2. 轉動旋鈕直到顯示分鐘轉至 25，按旋鈕確認。(如下圖) 然後畫面會自動跳至模式選項。



3. 此時自動進入麵包類型的選擇項，預設模式是“1”，即是冷藏麵包翻熱模式，按旋鈕確認。(如下圖)



如果需改變模式，可在此時轉動旋鈕至模式顯示為“2”，按旋鈕確認。

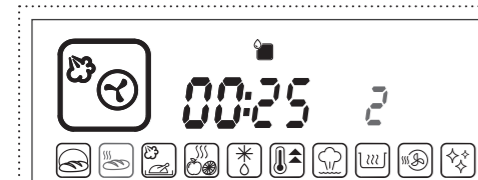

4. 設置完成，開始烹調。(如下圖)



注意：“組合鍵：爐腔溫度顯示”功能不適用於翻熱麵包模式。

操作方法說明

■ 慢煮模式

以蒸氣維持爐腔的溫度。以低溫慢煮，沒有經過高溫加熱，可使各種肉類和海鮮保存原有的鮮味。需配合真空袋使用。每次使用前，請確保水箱已加滿水。

	溫度	時間
開機預設	60°C	30 分鐘
設定範圍	50°C - 90°C	5 分鐘 - 6 小時 59 分鐘

例如：設置烹調時間為 40 分鐘，溫度為 60°C。

操作步驟：

1. 在待機狀態下，順時針旋轉旋鈕至  慢煮模式圖示閃爍，按旋鈕確認功能。(如下圖) 然後畫面會自動跳至小時選項。



2. 按旋鈕確認小時位 00 設定。(如下圖) 然後畫面會自動跳至分鐘選項。



3. 轉動旋鈕直到顯示分鐘轉至 40，按旋鈕確認。(如下圖) 然後畫面會自動跳至溫度選項。



4. 按旋鈕確認默認溫度 60°C 的設定。(如下圖)



5. 設置完成，開始烹調。(如下圖)



操作方法說明

■ 乾果模式

以低溫熱風抽乾食物，適合製作各種生果片，蔬菜片或肉乾。

	溫度	時間
開機預設	80°C	60 分鐘
設定範圍	40°C - 90°C	5 分鐘 - 12 小時 59 分鐘

例如：設置烹調時間為 2 小時，溫度為 90°C。

操作步驟：

1. 在待機狀態下，順時針旋轉旋鈕至  乾果模式圖示閃爍，按旋鈕確認功能。(如下圖) 然後畫面會自動跳至小時選項。



2. 轉動旋鈕直到顯示小時位轉至 02，按旋鈕確認。(如下圖) 然後畫面會自動跳至分鐘選項。



3. 按旋鈕確認分鐘位 00 設定。(如下圖) 然後畫面會自動跳至溫度選項。



4. 轉動旋鈕直到顯示溫度轉至 90°C，按旋鈕確認。(如下圖)



5. 設置完成，開始烹調。(如下圖)



操作方法說明

■ 解凍模式

以蒸氣去解凍冷藏或冷凍食物。每次使用前，請確保水箱已加滿水。

	溫度	時間
開機預設	55°C	30 分鐘
設定範圍	50°C - 60°C	5 分鐘 - 6 小時 59 分鐘

例如：設置烹調時間為 1 小時 40 分鐘，溫度為 60°C。

操作步驟：

1. 在待機狀態下，順時針旋轉旋鈕至  解凍模式圖示閃爍，按旋鈕確認功能。(如下圖) 然後畫面會自動跳至小時選項。



2. 轉動旋鈕直到顯示小時位轉至 01，按旋鈕確認。(如下圖) 然後畫面會自動跳至分鐘選項。



3. 轉動旋鈕直到顯示分鐘轉至 40，按旋鈕確認。(如下圖) 然後畫面會自動跳至溫度選項。

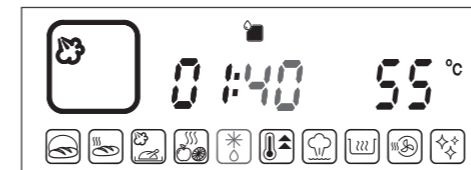

4. 轉動旋鈕直到顯示溫度轉至 60°C，按旋鈕確認。(如下圖)



5. 設置完成，開始烹調。(如下圖)

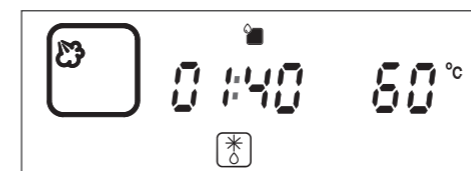

■ 預熱模式

預熱模式有蒸氣和烤焗兩種預熱模式選擇，使爐腔達至預設溫度。

	蒸氣預熱	烤焗預熱
	溫度	溫度
開機預設	100°C	180°C
設定範圍	50°C - 110°C	100°C - 230°C

兩種預熱功能的烹調時間均毋需設定；當達到設定的預熱溫度時，顯示屏會顯示“END”和發出聲效提示操作已完成。預熱進行中，顯示之時間為現在時間。如進行蒸氣預熱，每次使用前，請確保水箱已加滿水。

例如：以蒸氣進行預熱，設置烹調溫度為 100°C。

操作步驟：

1. 在待機狀態下，順時針旋轉旋鈕至  預熱模式圖示閃爍，預設的預熱模式是蒸氣模式，按旋鈕確認功能。（如下圖）



2. 此時自動進入烹調溫度的設置；按旋鈕確認預設溫度 100°C 的設定。（如下圖）



3. 設置完成，開始預熱。（如下圖）



例如：以烤焗進行預熱，設置烹調溫度為 200°C。

操作步驟：

1. 在待機狀態下，順時針旋轉旋鈕至預熱模式圖示閃爍，預設的預熱模式是蒸氣模式，轉動旋鈕切換至烤焗預熱模式，按旋鈕確認功能。（如下圖）



2. 此時自動進入烹調溫度的設置；轉動旋鈕直到顯示溫度轉至 200°C，按旋鈕確認。（如下圖）



3. 設置完成，開始預熱。（如下圖）



預熱結束時，顯示屏顯示會“END”及發出聲效提示操作已完成（如下圖）。預熱完成後，客人可以根據需要，選擇其他烹調模式進行烹調。



注意：“烹調過程中調校 / 結束後追加時間功能”功能不適用於此模式。

操作方法說明

■ 消毒模式

以 110°C 高溫蒸氣消毒，可消毒餐具或嬰兒奶瓶等。每次使用前，請確保水箱已加滿水。

	溫度	時間
開機預設	110°C	30 分鐘
設定範圍	不可調校	5 分鐘 - 6 小時 59 分鐘

例如：設置烹調時間為 35 分鐘。

操作步驟：

1. 在待機狀態下，順時針旋轉旋鈕至  消毒模式圖示閃爍，按旋鈕確認功能。(如下圖) 然後畫面會自動跳至小時選項。



2. 按旋鈕確認小時位 00 設定。(如下圖) 然後畫面會自動跳至分鐘選項。



3. 轉動旋鈕直到顯示分鐘轉至 35，按旋鈕確認。(如下圖)



4. 設置完成，開始烹調。(如下圖)



操作方法說明

■ 保溫模式

以熱風保溫食物，適合將剛煮的食物保溫。

	溫度	時間
開機預設	55°C	30 分鐘
設定範圍	50°C - 60°C	5 分鐘 - 3 小時 59 分鐘

例如：設置烹調時間為 1 小時 30 分鐘，溫度為 60°C。

操作步驟：

1. 在待機狀態下，順時針旋轉旋鈕至  保溫模式圖示閃爍，按旋鈕確認功能。(如下圖) 然後畫面會自動跳至小時選項。



2. 轉動旋鈕直到顯示小時位轉至 01，按旋鈕確認。(如下圖) 然後畫面會自動跳至分鐘選項。



3. 按旋鈕確認分鐘位 30 的設定。(如下圖) 然後畫面會自動跳至溫度選項。



4. 轉動旋鈕直到顯示溫度轉至 60°C，按旋鈕確認。(如下圖)



5. 設置完成，開始烹調。(如下圖)

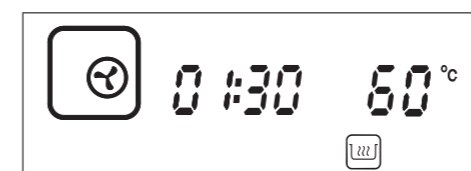

■ 烘乾爐腔模式

此模式會以高溫加熱爐腔，蒸發爐腔中多餘水份及蒸氣。此功能適用於任何以蒸氣烹調的模式後使用。

	溫度	時間
開機預設	不可調校	25 分鐘
設定範圍	不可調校	不可調校

操作步驟：

- 在待機狀態下，順時針旋轉旋鈕至  烘乾爐腔模式圖示閃爍，按旋鈕確認功能。(如下圖)



- 開始烹調。(如下圖)





注意：1. “組合鍵：爐腔溫度顯示” 功能不適用於此模式。

- “烹調過程中調校 / 結束後追加時間” 功能不適用於此模式。

■ 除垢模式

使用蒸氣功能會導致機內及水管內產生水垢。

累積使用蒸氣模式或其他帶有蒸氣功能模式的時間達到 100 個小時，顯示屏上  除垢提示圖示會亮起，提醒用戶進行除垢模式。直至用戶啟動除垢模式後，圖示才會熄滅。

除垢模式分 3 個階段，分別進行 1 次除垢和 2 次除垢清潔。在整個除垢過程中，需要更換水箱內的液體 3 次，並需要倒掉接水盤內的污水。當需要倒掉接水盤內的污水時，顯示屏上  會相應亮起去提醒用戶。除垢模式需配合除垢劑使用 (例如：Wpro 咖啡機除鈣去垢劑)。進行除垢模式時，建議使用除垢劑和淨水分量如下：

第 1 階段：除垢，時間為 30 分鐘。建議使用 50 毫升除垢劑和 500 毫升淨水。



第 2 階段：第 1 次除垢清潔，時間為 10 分鐘。建議使用 550 毫升淨水。

第 3 階段：第 2 次除垢清潔，時間為 10 分鐘。建議使用 550 毫升淨水。

	溫度	時間
開機預設	不可調校	50 分鐘
設定範圍	不可調校	不可調校

操作步驟：

- 第 1 個階段：除垢

- 先將 50 毫升除垢劑和 500 毫升淨水倒入水箱至水箱上  除垢圖標位置。
- 在待機狀態下，順時針旋轉旋鈕至  除垢模式圖示亮起，按旋鈕確認功能。(如下圖)





- 開始除垢模式。(如下圖)





- 第 1 個階段需時 30 分鐘，程式完成後，顯示屏上的時間位會閃動，並發出聲效去提示第 1 個階段完成。同時顯示屏上  接水盤圖示會亮起，提醒用戶倒掉接水盤內的污水。
- 請倒掉污水，並裝回接水盤。

- 第 2 個階段：第 1 次除垢清潔

- 打開爐門，將 550 毫升淨水倒入水箱至水箱上  除垢圖標位置。
- 將水箱放回機內並關上爐門，程式會自動啟動，繼續除垢清潔工作。
- 第 2 個階段完成後，顯示屏上的時間位會閃動，並發出聲效提示第 2 個階段完成，同時顯示屏上  接水盤圖示會亮起，提醒用戶倒掉接水盤內的污水。
- 請倒掉污水，並裝回接水盤。

操作方法說明

- 3 第 3 個階段：第 2 次除垢清潔
 - A. 打開爐門，將 550 毫升淨水倒入水箱至水箱上  除垢圖標位置。
 - B. 將水箱放回機內並關上爐門，程式會自動啟動，繼續除垢清潔工作。
 - C. 第 3 個階段完成後，顯示屏會顯示“End”提示，並發出聲效提示，同時顯示屏上  接水盤圖示會亮起，提醒用戶倒掉接水盤內的污水。
 - D. 請倒掉污水，並裝回接水盤。
4. 除垢完成。

注意：1. “組合鍵：爐腔溫度顯示”功能不適用於此模式。

2. “烹調過程中調校 / 結束後追加時間”功能不適用於此模式。

3. 除垢過程中，如操作有誤（包括操作過程中按暫停或沒有按指示下開關爐門等），除垢模式程式會被擾亂而無法正常運作。建議重新啟動除垢模式並按照除垢模式中的指示再次操作。

操作方法說明

■ 預約功能

在進行預約功能設定前，必須先完成時鐘設定。時鐘設定可參見本說明書第 13 頁“設置時鐘”內說明。

例如：現時時間為 16:30，設置預約底部燒烤模式，烹調時間為 40 分鐘，溫度為 210°C，結束時間為 18:00。

操作步驟：

1. 在待機狀態下，順時針旋轉旋鈕至  底部燒烤模式圖示亮起，按旋鈕確認功能。（如下圖）然後畫面會自動跳至小時選項。



2. 按旋鈕確認小時位 00 設定。（如下圖）然後畫面會自動跳至分鐘選項。



3. 轉動旋鈕直到顯示分鐘轉至 40，按旋鈕確認。（如下圖）然後畫面會自動跳至溫度選項。



4. 轉動旋鈕直到顯示溫度轉至 210°C，按設置鍵  確認。（如下圖）



5. 此時畫面會進入預約烹調結束時間的小時位設置，時鐘位顯示的時間會切換回現時的時間 16:30，小時位“16”會閃爍；同時，顯示屏上方  預約功能圖示會閃爍顯示，表示正在進行預約功能設定。（如下圖）



6. 轉動旋鈕直到小時位轉至 18，按旋鈕確認。(如下圖) 然後畫面會自動跳至分鐘選項。



7. 轉動旋鈕直到顯示分鐘轉至 00，按旋鈕確認。



8. 顯示屏上 預約功能圖示會亮起，預約烹調時間切換回現時時間 16:30。表示預約設置完成。(如下圖)

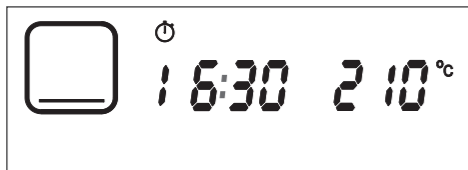

A. 查詢預約狀態

可按設置鍵 3 秒，以查詢預約結束時間，預約功能圖示會閃爍顯示；再按設置 3 秒，可返回預約設置畫面。

B. 取消預約設定：

如需取消預約設定，可直接按 電源鍵，即退出預約設定，並自動返回到待機畫面。

注意：預約模式適用於 9 個主要烹調模式，翻熱麵包模式，慢煮模式和乾果模式。(詳情請參閱第 8-10 頁控制面板 - 主要功能介紹 / 詳細說明)

建議：預約設置後，可啟動兒童安全鎖功能，以防止不小心觸摸到控制面板而誤將預約取消。童鎖設置可參見本說明書第 7 頁“控制面板 - 基本功能說明”內說明。當達到預約的啟動時間，蒸焗爐會正常啟動，不受童鎖影響。

■ 烹調過程中調校 / 結束後追加時間功能

A. 烹調過程中進行調校

在烹調過程中，可以根據需要去增加或減少烹調時間和溫度。

例如：已設定的烹調時間 01:40 和溫度 90°C，改為烹調時間 02:00 及溫度 100°C。

操作步驟：

1. 於烹調過程中，按旋鈕暫停烹調，時間位會閃爍。(如下圖)



2. 按設置鍵 ，自動進入調較設置，小時位會閃爍；顯示屏上 增加烹調時間圖示會亮起。(如下圖)



3. 轉動旋鈕直到顯示小時位轉至 02，按設置鍵 確認。(如下圖) 然後畫面會自動跳至分鐘選項。



4. 轉動旋鈕直到顯示分鐘轉至 00，按設置鍵 確認。(如下圖) 然後畫面會自動跳至溫度選項。



5. 轉動旋鈕直到顯示溫度轉至 100°C，按旋鈕確認。(如下圖)



6. 設置完成，開始新設置的烹調設定。(如下圖)



B. 烹調過程結束後追加功能

在烹調過程結束後，可以根據需要去增加烹調時間。

	溫度	時間
設定範圍	不可調校	1 分鐘 - 59 分鐘

烹調過程結束後，顯示屏會顯示“End”並發出聲效提示。同時顯示屏上  增加烹調時間圖示會亮起。

 接水盤圖示會閃爍約 3 分鐘（註：接水盤圖示只會在使用蒸氣相關功能後才亮起）。（如下圖）

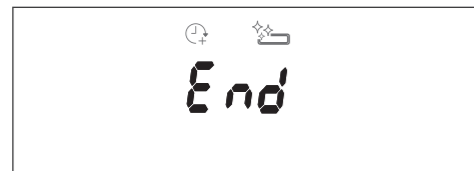

如增加烹調時間，可根據以下步驟操作：

例如：烹調結束後，追加烹調時間 3 分鐘。

操作步驟：

1. 按旋鈕確認追加時間功能，顯示屏會自動跳至分鐘位選項。（如下圖）



2. 轉動旋鈕直到顯示分鐘轉至 03，按旋鈕確認。（如下圖）



3. 設置完成，即啟動追加時間烹調。（如下圖）



注意：如果用戶在烹調結束後，3 分鐘內沒有進行任何操作，將自動返回到待機狀態。

■ 餘溫高溫提示

在待機狀態或省電模式狀態下，完成煮食後，只要爐腔內的溫度高於 50°C，顯示屏上  高溫提示圖標就會亮起，提醒用戶爐腔內溫度較高，不適宜進行清潔（如下圖）。直到爐腔內的溫度低於 50°C，顯示屏上高溫提示圖標才會消失，建議用戶於圖示消失後才進行清潔。



■ 童鎖功能

用來鎖住按鍵，防止兒童在沒有成人指導的情況下使用蒸焗爐。

A. 啟動童鎖：

可長按  童鎖鍵 3 秒鐘，進入童鎖狀態，此時顯示屏上方的童鎖圖示亮起。（如下圖）

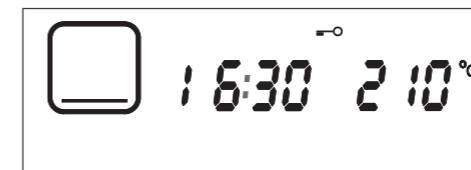

B. 解除童鎖

長按  童鎖鍵 3 秒鐘，即可解除童鎖，此時顯示屏上方的童鎖圖示會消失。

■ 清潔保養

- 在正常情況下，清潔產品是唯一所需的保養方法。
- 請務必在蒸焗爐冷卻狀態下，圖示消失後進行清潔與保養。清潔之前，需切斷電源。請勿使用蒸氣清潔器清洗本蒸焗爐。
- 蒸焗爐必須保持清潔，否則可能導致爐身受到腐蝕，縮短蒸焗爐的使用壽命，所以每次使用蒸焗爐後，必須進行清潔。
- 切勿使用含金屬成份的清潔布、磨砂型潔具、鋼刷、表面粗糙的抹布，否則會對爐身表面、爐門、控制面板、爐內壁及配件造成損害。應以沾有溫和洗潔精的海綿或軟布或噴上玻璃清潔劑的廚房紙巾進行清潔。每次使用後，確保爐腔（包括爐腔底部）是乾透。
- 鹽份是具侵蝕性的物質，一旦積聚在爐腔內，將形成銹漬。一些帶酸性的醬汁，例如茄汁、芥末和醃製食品含有氯和酸的化學成份。而該等成份會對鋼表面造成影響。所以建議每次使用蒸焗爐後，必須進行清潔。
- 切勿讓油脂及食物碎屑殘留於爐門及爐門封邊上。假如爐門封邊清潔處理不善，或會影響蒸焗爐操作時，爐門無法完全關上，繼而導致機前方及兩側部份損壞。
- 每次使用後，
 - 清理蒸焗爐門底下的黑色接水盤的積水，以防止積水滿瀉，濺濕及弄髒檯面。（接水盤是可以拆下的。它會盛載每次蒸煮後玻璃門開門時滴下的倒汗水。）
 - 清理殘留在水箱未用完的水。
 - 每次使用後，打開爐門 15-30 分鐘或進行烘乾爐腔模式，以風乾爐腔及門框。
- 如果爐腔非常骯髒，可於清潔前，先以「消毒模式」（110°C），蒸煮 30 分鐘，來溶解油漬，待機身冷卻後，才開始進行清潔。如遇上頑固的油漬，可重覆以上的步驟。切勿使用含金屬成份的清潔布、磨砂型潔具、鋼刷、表面粗糙的抹布清潔。
- 建議最少每一個月或除垢圖示亮起時進行“除垢模式”清潔。
- 建議使用直接從水喉取的自來水、飲用食水或蒸餾水作烹調用，但避免使用礦泉水。
- 水箱必須每月至少檢查一次。如有需要，取出水箱，擦洗乾淨後再放回原處。
- 若長時間不使用本產品時，應拔掉電源插頭，保持爐腔清潔，並將蒸焗爐放置在通風、乾燥及沒有腐蝕性氣體的環境中。
- 每次使用後，應清潔和風乾爐腔（包括爐腔頂部，左右兩側和底部）。如爐底或爐腔有變黃的情況，可以使用不銹鋼清潔劑去除污漬。（例如：Wpro 不銹鋼清潔劑）

■ 如何拆下爐腔內隔熱罩

A. 內隔熱罩拆卸

- 使用套筒手板套住固定內隔熱罩的螺絲，按逆時針方向手扭動，可拆下螺絲，取下內隔熱罩；（如下圖）

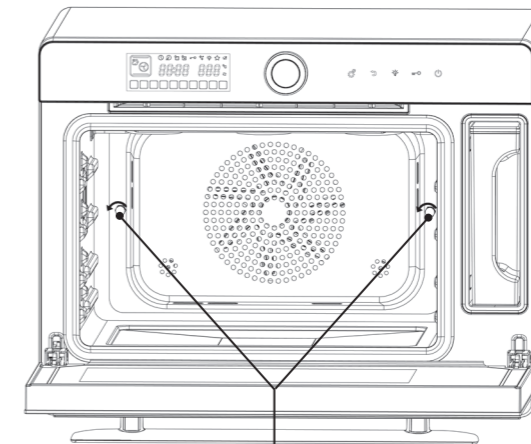

使用套筒手板，逆時針方向扭動螺絲，取下螺絲，取出內隔熱罩。

- 清潔拆下來的內隔熱罩。（如下圖）

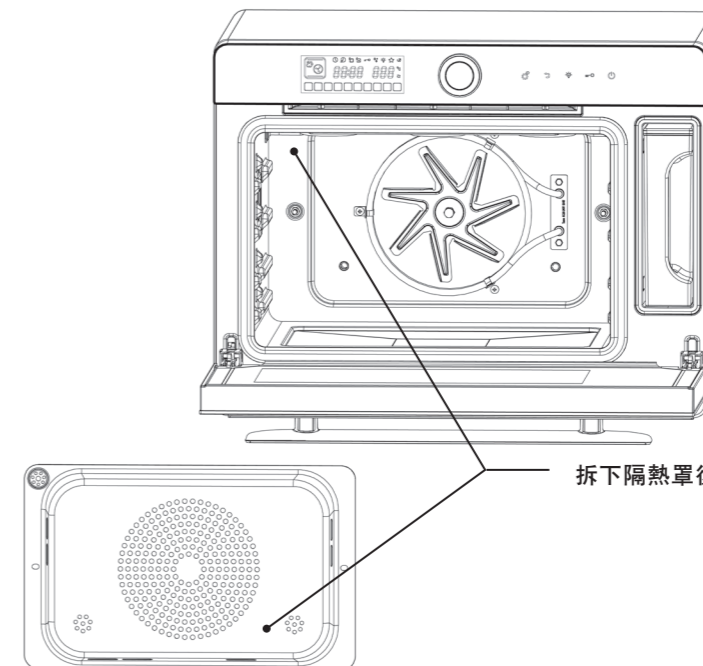

拆下隔熱罩後，清洗腔體後板及內隔熱罩。

B. 內隔熱罩安裝

將內隔熱罩放入爐腔並對應上背部的螺絲位，用 2 顆配套螺絲順時針方向扭緊，確保牢固。

注意：整個拆卸與安裝過程，必須小心操作，避免刮傷手或刮花腔體表面。

■ 如何拆下上發熱管

1. 用雙母指按住上發熱管的固定鋼架 (圓形扣位的左右兩旁), 稍微用力往後推, 如下圖箭頭所示位置;

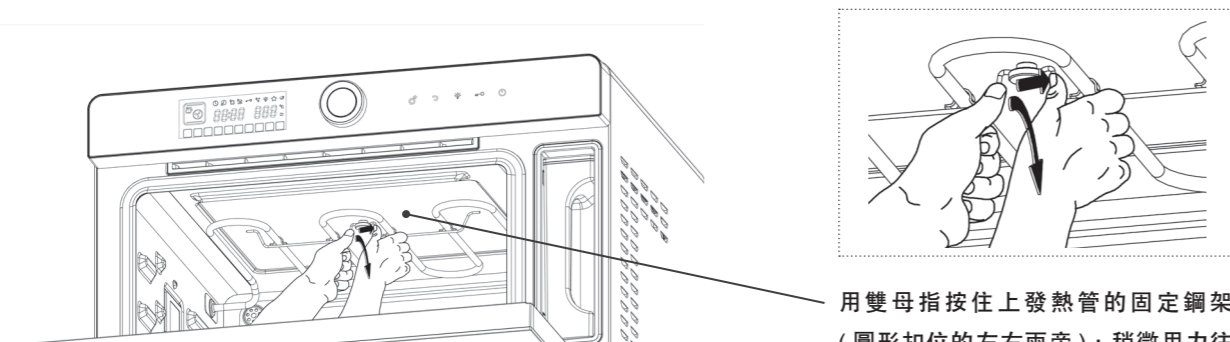

用雙母指按住上發熱管的固定鋼架 (圓形扣位的左右兩旁), 稍微用力往後推。脫扣後, 發熱管會跌下。

2. 鋼架脫落後, 將上發熱管輕輕往下拉, 即可對爐腔頂部進行清潔; (如下圖)

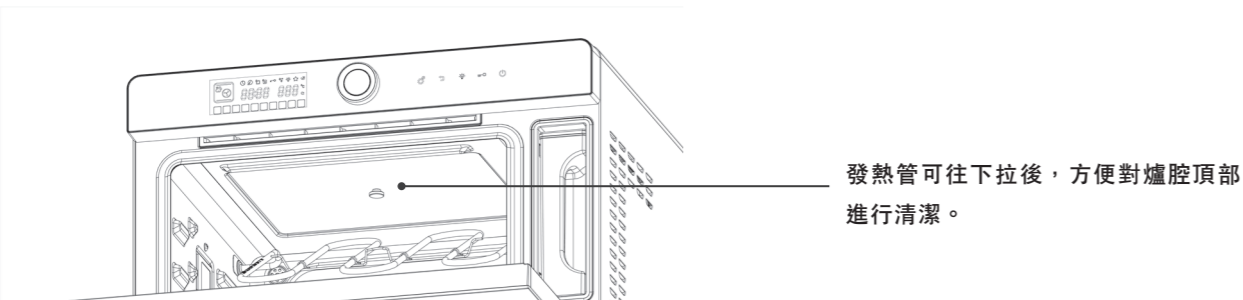

發熱管可往下拉後, 方便對爐腔頂部進行清潔。

3. 清潔完成後, 將上發熱管稍微用力往後壓, 扣回上發熱管的固定件。

注意: 1. 在扣合的時候, 用雙母指並需要稍微用力往後壓, 以便鋼架扣位更加容易扣回固定件。

2. 需確保爐腔冷卻,  圖標消失後, 才進行清潔。

■ 故障排解

A. 如出現以下情況 如出現以下情況

	如以下情況出現...	可能成因	解決方法
1	顯示屏上顯示消失	蒸焗爐沒有連接到電源	確保蒸焗爐連接電源
		插座有問題	用其他電器再測試插座是否有問題
		電源線不能正常工作	與客戶服務部聯絡
2	蒸焗爐不能操作	電源插頭沒有插好	重新插好電源插頭
		爐門沒有關好	重新關閉爐門
		水箱沒有放置妥善	重新放回水箱並妥善安裝
		電路版損壞	與客戶服務部聯絡
3	顯示屏顯示異常	兒童安全鎖被鎖住	解除兒童安全鎖
		顯示屏損壞	與客戶服務部聯絡
4	烹調期間大量排出水或蒸氣	電路板損壞	
		兒童安全鎖被鎖住	
5	爐燈不亮	爐門沒有關上	重新把爐門關上
		爐門封邊損壞	與客戶服務部聯絡
6	風扇不能正常運作	爐燈損壞	與客戶服務部聯絡
		主機電腦板損壞	
7	按鍵失靈	風扇電機損壞	與客戶服務部聯絡
		主機電腦板損壞	
8	無蒸氣噴出	導電橡膠按鍵裝置錯誤或損壞	與客戶服務部聯絡
		水管被折疊、堵塞或損壞	
		水泵損壞	
9	蒸焗爐漏水	水箱內無水或水箱沒有放置妥善	與客戶服務部聯絡
		沒有把儲水箱完整推進到位	

B. 下列情況均屬正常

	情況	原因
1	首次使用各種燒烤或烤焗模式時，蒸焗爐有少量白煙冒出及異味。	這是由爐腔裡保護部件的過多油脂揮發所引起的。這屬於正常現象，非損壞。
2	使用蒸氣相關功能時有聲音	水箱吸水時或會混入空氣造成聲音，是正常現象。
3	蒸氣凝結在出風口或蒸氣從爐門四周縫隙處溢出	使用與蒸氣相關的功能時，蒸焗爐運轉過程中爐腔內會產生大量蒸氣，爐腔內多餘的蒸汽會通過出風口排出，但少部分蒸汽由於環境溫度，會凝結在出風口口處，或部分蒸氣可能從門縫四周漏出，這是正常現象。
4	烹調結束後風扇仍在工作	烹調結束後，風扇會延時工作 3 分鐘，將腔體內的熱量排出。這是產品冷卻爐腔和電子元件，屬於正常現象。
5	如發現有白色粉末在入氣口流出	這是水垢，是正常現象。如發現白色粉末（水垢），請啟動除垢模式，以清潔水管。
6	如爐腔 / 爐底有變黃現象	不銹鋼受熱後，如清潔處理不善，會產生變黃現象。建議每次使用蒸焗爐後，進行清潔以避免變黃現象產生。

■ 產品規格

型號	CS2320
額定電壓及額定頻率	220~240V / 50~60Hz
額定輸入功率	2100W
產品尺寸（高 × 闊 × 深）	405 x 530 x 457 毫米
爐腔尺寸（高 × 闊 × 深）	244 x 387 x 342 毫米
爐腔容積	32L
淨重	約 25 kg

Table of Contents

■ General Preparation and Advice before Use

	Page
Important Safety Information	46
Precautions before First Use	46
Precautions and Advice	46-47
Mounting the Appliance	48
Earthing Instructions	49
Appliance and Accessories Chart	49-50
Control Panel	51
Control Panel – Basic Functions	52
Control Panel – Special Functions	53
Control Panel – Major Features	54
Control Panel – Description of Major Features.....	55-57
Use and Cooking Tips	58
Recommended Recipes	59

■ Operation Instructions

	Page
Setting the Clock	60
Steam Mode	61
Turbo Convection Mode	62
Upper/Bottom Grill/Conventional Bake Mode.....	63
Convection Mode	64
Forced Air Mode	65
Forced Air + Steam Mode	66
Convection + Steam Mode	67
Proving Mode	68
Bread Reheat Mode	69
Slow Cook Mode	70
Drying Fruit Mode	71
Defrost Mode	72
Preheat Mode	73-74
Sterilization Mode	75
Keep Warm Mode	76
Cavity Drying Mode	77
Descaling Mode	78-79
Preset Function	80-81
Adjust or Increase the Cooking Time	82-83
during/after Cooking is Completed	
Residual Heat Indicator	84
Child Lock	84

■ Cleaning and Maintenance

	Page
Cleaning and Maintenance	85
How to Remove the Back Panel	86
How to Lower the Upper Heater	87

■ Others

	Page
Troubleshooting	88-89
Product Specifications	90

General Preparation and Advice before Use

■ Important Safety Information

This manual contains important information on safety, use and maintenance of the product. Please read the manual carefully and keep it in an easily accessible place for future reference.

■ Precautions before First Use

1. Two or more people are required to install or move this appliance as it is heavy. It must be securely placed on a firm and level surface. Failure to do so can cause physical injuries or damage to the appliance.
2. This appliance is designed solely for indoor and domestic use. Follow the cooking instructions indicated in the manual. Do not use this appliance for outdoor, commercial or any other purposes.
3. Check that the voltage on the rating label corresponds to the voltage in your home.
4. Ensure that the appliance is not damaged. Do not operate the appliance if it has a damaged mains cord or plug. If it is not working properly, or it has been damaged or dropped. Please contact Whirlpool Customer Services.
5. Do not immerse the power cord or plug in water. Keep the power cord away from hot surfaces to avoid electrical shock, fire or other accidents.
6. This combi steamer is designed for free standing installation. Do not install as a built-in appliance.
7. Allow adequate ventilation space on all sides and do not place any object on top. Keep a minimum distance of 5cm between the combi steamer and any overhead wall cabinet; and a minimum distance of 1cm between both sides of the appliance and the walls.
8. To avoid damage to the appliance, do not block the ventilation vent.
9. Run the "Sterilization Mode" for 30 minutes to clean and sterilize the combi steamer before first use.
10. The manufacturer disclaims all liability for faults arising from improper use of this appliance.
11. Warm steam is emitted from the front ventilation vent. Blocking the outlets will result in damage to the combi steamer.
12. Use heat resistant utensils for cooking, such as heat resistant glass and heat resistant plastic. Non-heat

resistant containers should not be used with combi steamer. For steaming functions, container with heat resistant >120°C should be used. For convection functions, container with heat resistant >250°C should be used.

13. Odour will be emitted from the cavity when using different baking functions for the first time. It is normal.

■ Precautions and Advice

1. Stop using the combi steamer and contact Whirlpool Customer Service immediately if the door or door seal is damaged.
2. If the power cord is damaged, it must be replaced by the manufacturer, its service agent or similarly qualified persons in order to avoid a hazard.
3. To avoid fire hazard or explosion, do not heat or use flammable materials in or near the appliance.
4. To avoid fire hazard, do not use the appliance to dry cloth, paper, spices, herbs, wood, flowers or other flammable objects.
5. Overcooking food poses a fire hazard.
6. Never leave the appliance unattended during use, particularly when cooking with paper, plastic or other flammable materials. Paper may catch fire or get burned and some plastic materials may melt when heating up food with the appliance. If any object inside or outside the appliance is ignited or emits smoke, close the appliance door and switch off the combi steamer. Disconnect the power supply and the socket with circuit leakage breaker.
7. This combi steamer is specifically designed to heat or cook food. It is not designed for industrial or laboratory used.
8. This combi steamer is not intended for use by persons (including children) with reduced physical, sensory or mental capabilities, or lack of experience and knowledge, unless under supervision or instruction of a person responsible for their safety.
9. After cooking, clean the combi steamer only when it has completely cooled down. Wipe away any food debris or waste inside the oven. Top of the oven cavity gets burned easily and care should be taken to keep it clean. For best cooking results, keep the combi steamer completely dry by opening the door every time after cooking.

General Preparation and Advice before Use

10. Use oven gloves to take food and containers out of the appliance to avoid burning.
11. To avoid a hazard, do not touch the upper heater in the oven when using the appliance.
12. Do not use the combi steamer for storage.
13. After heating food or beverages in nursing bottles or infant food cans, always stir and check the temperature before serving. This will ensure that heat is evenly distributed and the risk of scalding or burns can be avoided.
14. Wait 10-15 minutes after each program before continuing to another mode.
15. Steam will be rapidly evaporated and not easily seen if the oven cavity at the high temperature or just finished all convection modes. It is normal.
16. Do not touch the door and door frame when using the appliance.
17. Fill the water tank with tap water, drinking water or distilled water up to the MAX mark (maximum level). Insert the water tank into the appliance completely until it clicks to ensure it is fixed in the right position.
18. If the water tank is cracked or damaged, stop using it to avoid power leakage or electrical shock caused by water leakage.
19. For hygienic reasons and prevent condensation inside the combi steamer. Empty the water tank and keep the combi steamer completely dry every time after cooking.
20. Do not fill the water tank with any liquids other than water (except descaler).
21. To avoid condensation and oven temperature drops, do not open the oven door when cooking with "Steam" mode unless it is absolutely necessary. If you have opened the oven door, extend the cooking time accordingly.
22. If it is necessary to open the oven door to turn the food or for other purposes during cooking, keep a distance from the oven door (particularly the face) to prevent scalding.
23. All maintenance and repairs should be carried out by a similarly qualified person. It is dangerous to fix the appliance by anyone except a similarly qualified person. Never dismantle, repair or modify the appliance by yourself.
24. Accessible parts of the appliance may become hot during use. Young children should be kept away.

25. When combi steam is plugged, never touch the appliance, the power cord or plug with wet hands or other wet body parts.
26. Do not place or hang any objects on the oven door or the door handle. It may affect door's opening and closing or damage the door hinges.
27. After cooking ends, the electric fan will continue running for a certain period of time to cool down the cavity.
28. The combi steamer and its parts should be kept clean. Failure to do so will result in deterioration of the appliance surface and affect its life cycle. It may also cause danger.
29. Remove the power supply plug before cleaning. Do not use corrosive cleaners as they may cause damage or corrosion.
30. Water in the water tank will be heated up and discharged to the drip tray during "Descaling Mode". Do not allow children to touch or go near the combi steamer.
31. Remove the power supply plug before cleaning the cavity. If you need to clean the fan, remove the back panel of the oven carefully. Put it back in place as instructed after cleaning. (Please refer to "How to Remove the Back Panel" in this instruction manual)
32. Clean dust from the power supply plug on a regular basis. If the product will not be used for a long time, remove the power supply cord. Do not pull the power supply cord but hold the plug to remove it.
33. Never leave the combi steamer in operation unattended.
34. Overheated fat and oil catch fire easily. Except grilling meat, heating oil during cooking is dangerous. Such practice should never be allowed.
35. Maximum load for the oven door is 7kg. To avoid damaging the combi steamer, do not place food or heavy objects on the oven door.

General Preparation and Advice before Use

■ Mounting the Appliance

1. Good ventilation must be ensured around the combi steamer. Do not place any objects on top of the appliance and allow a minimum distance of 5cm between the combi steamer and any overhead wall cabinet. Keep a minimum distance of 1cm between both sides of the appliance and walls. Appliance back can be closed to the wall.

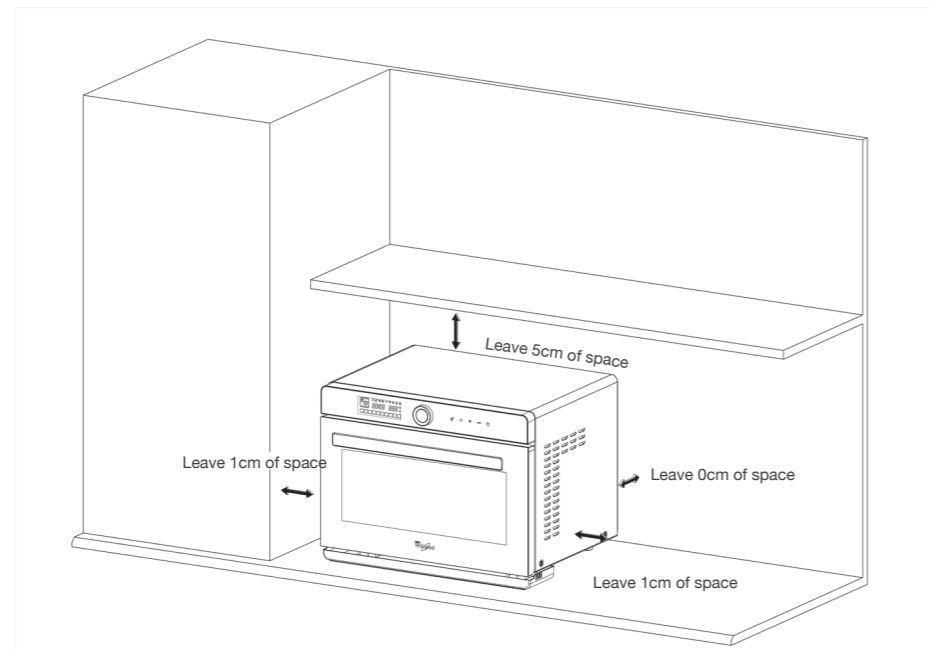

2. To prevent fire, do not block the air outlet and steam outlet. Maintain the product regularly and prevent foreign matter and dust from blocking the air outlet and steam outlet.
3. Do not put the appliance in a hot or humid place, such as gas stove, electrified areas or sink.
4. This appliance must be placed on a firm and stable surface.

General Preparation and Advice before Use

■ Earthing Instructions

This appliance must be earthed. In case of electric leakage, the ground can provide a current loop to avoid electric shock. The power supply plug that comes with this appliance must be inserted into a single-phase-bipolar socket with grounding.

■ Appliance and Accessories Chart

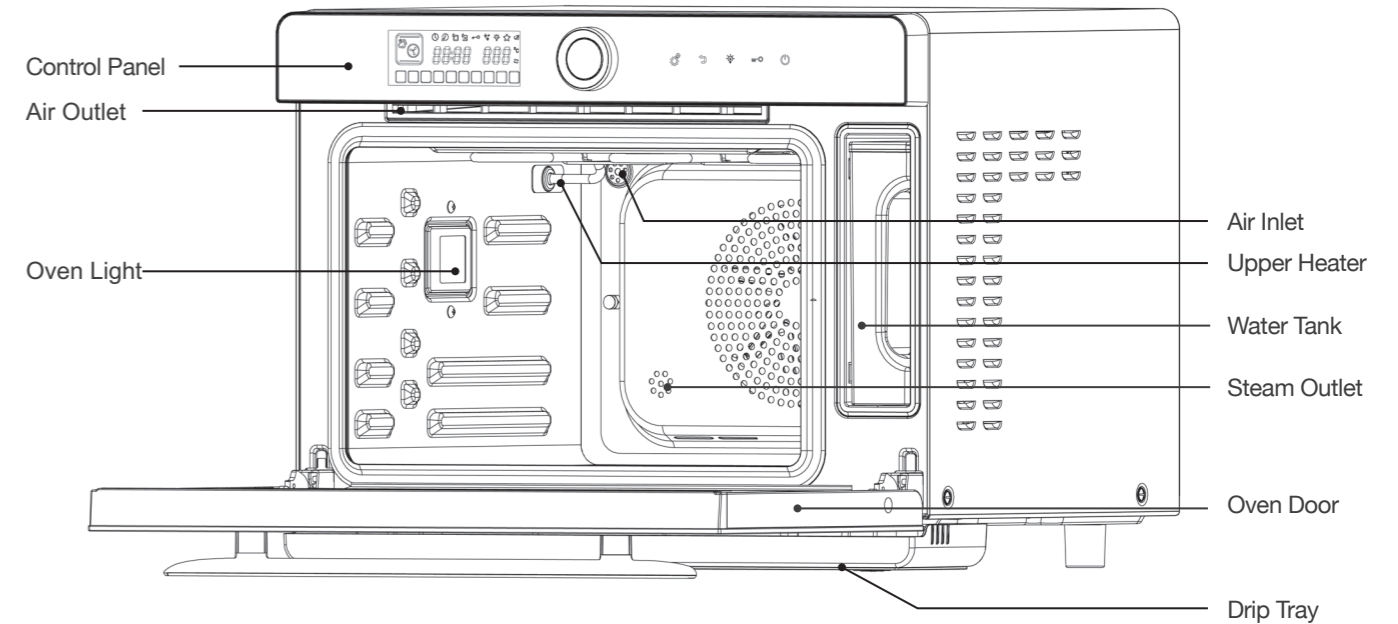

1. Control Panel: To operate the combi steamer (For details see the control panel instructions P.51-57).
2. Air Outlet: To exhaust excessive steam from the cavity.
3. Oven Light: To light up the oven to observe the food being cooked.
4. Air Inlet: To discharge excess steam from the cavity to Air Outlet.
5. Upper Heater: To generate heat to cook food.
6. Water Tank: To be filled with water to generate steam.
7. Steam Inlet: To release steam into the cavity.
8. Oven Door:
 1. Make sure the door is closed before starting to cook.
 2. The combi steamer will pause if you open the oven door during cooking. The selected mode will continue automatically once the door is closed.
9. Drip Tray: To collect excess water when the door is open and foul water from Descaling Mode.

General Preparation and Advice before Use

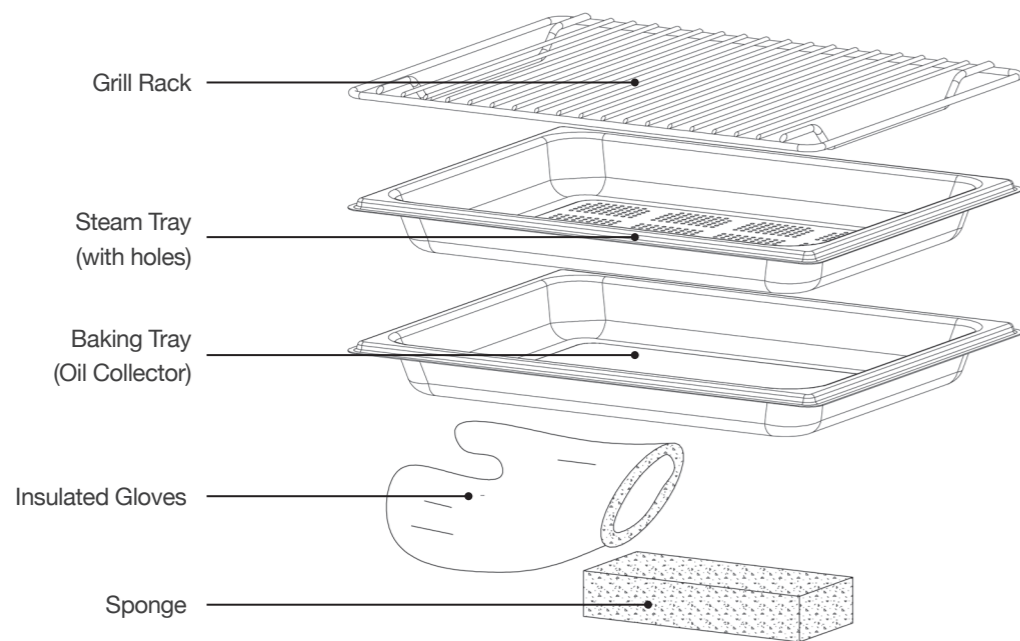

1. Grill Rack

- (A) Mainly for modes that cook with the heater, such as “Grill”, “Convection” or “Forced Air” mode.
- (B) For multi-layers cooking, it is recommended to place the grill rack on the lowest level for better air circulation and even oven temperature.
- (C) When grilling food without any container, please place baking paper or aluminum foil onto the grill rack before cooking.

2. Steam Tray (with holes)

- (A) Mainly for the “Steam” mode. Designed with vent holes, it can also be used for other cooking modes.
- (B) For multi-layer cooking, it is recommended to place the steam tray on a lower level to aid internal air circulation and even oven temperature. For 3 layers cooking, it is recommended to place steam tray on a middle level.

3. Baking Tray (oil collector)

- (A) Mainly for the “Forced Air + Steam”, “Convection + Steam” or “Forced Air” mode. It can also be placed at the bottom level to collect dripping oil when cooking meat.
- (B) When baking food without any container, please place baking paper or aluminum foil onto the baking tray.

4. Insulated gloves

To take food or rack out from the combi steamer.

5. Sponge

To remove condensation inside the oven.





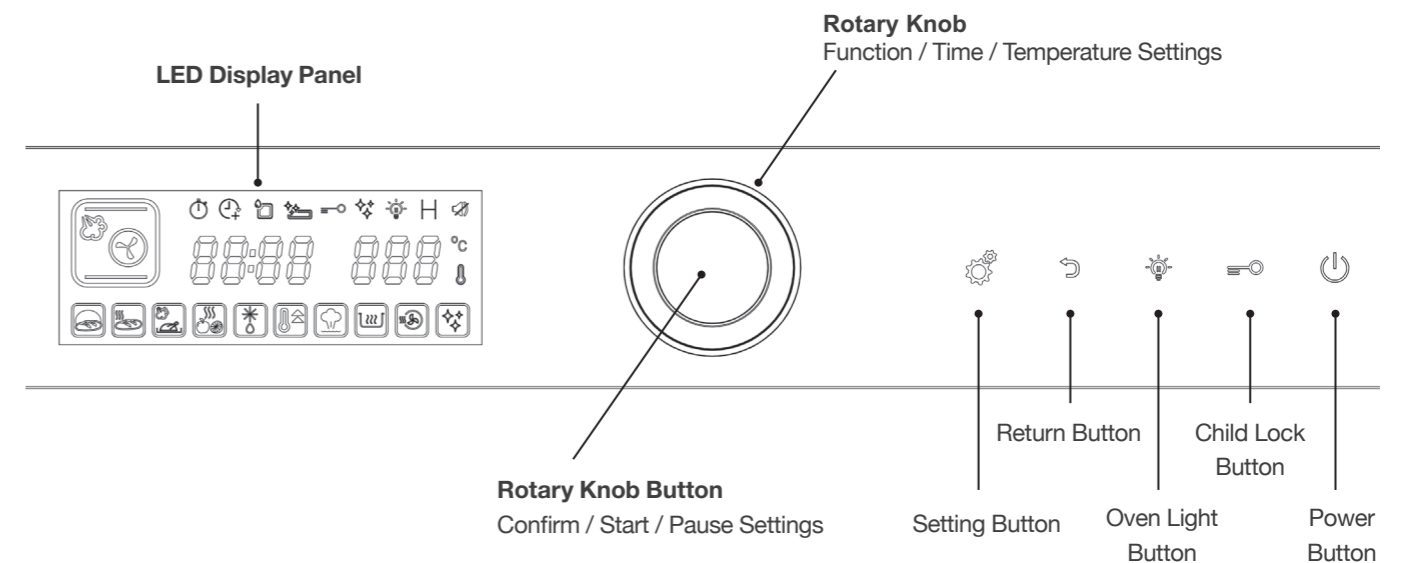

General Preparation and Advice before Use

■ Control Panel



General Preparation and Advice before Use

■ Control Panel – Basic Functions

Icon	Function Descriptions
	<p>Rotary Knob Function / Time / Temperature Settings</p> <p>Rotary Knob Button Confirm / Start / Pause Settings</p>
	<p>Setting Button</p> <ol style="list-style-type: none"> Setting the clock: In standby mode, press and hold the setting button for 3 seconds to enter the clock setting screen to set the clock (See “Setting the Clock” on page 60 for detailed instructions). Preset function: After setting the cooking mode, cooking time and cooking temperature, press the setting button to enter the preset screen to preset the timer (See “Preset Function” on page 80-81 for detailed instructions). In pause mode, press the setting button to reset cooking time and temperature (See “Adjust the cooking time during cooking process” on page 82 for detailed instructions).
	<p>Return Button</p> <ol style="list-style-type: none"> Return / Reset; Press the return button during setting to go back to the previous screen or reset cooking modes or cooking time. Mute Mode To activate mute mode: In standby mode, press and hold the button for 3 seconds to activate the mute mode. The mute icon lights up on the display panel. To release mute mode: In standby mode, press and hold the return button for 3 seconds while it is activated.
	<p>Oven Light Button</p> <ol style="list-style-type: none"> Touch once to switch the light on for 3 minutes. The oven light icon will not light up on the display panel. Press and hold for 3 seconds, the oven light will stay on. The oven light icon will light up on the display panel. Press and hold for 3 seconds again to switch off the oven light. The oven light will light up for 3 minutes when the door is open.
	<p>Child Lock Button</p> <p>Press and hold the button for 3 seconds to activate / release the child lock.</p> <p>To activate child lock: Press and hold the button for 3 seconds. The control panel will be locked and no operation is possible. The child lock icon lights up on the display panel.</p> <p>To release child lock: To release, press and hold the child lock button for 3 seconds while it is activated.</p>
	<p>Power Button</p> <p>After 5 minutes without operation after activate the combi steamer, including opening or closing the oven door. Combi steamer will automatically enter to power-saving mode, display panel goes out. In power-saving mode, only power button is operable.</p>

General Preparation and Advice before Use

■ Control Panel – Special Functions

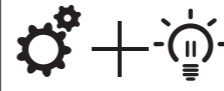
Combination Button	Icon	Function Descriptions
<p>Combination Button: Cavity temperature display</p>		<p>To change temperature display to actual oven temperature, press the 【Setting】 + 【Oven Light】 buttons simultaneously for 3 seconds during operation.</p> <p>To go back to the set cooking temperature, press the 【Setting】 + 【Oven Light】 buttons simultaneously for 3 seconds.</p>

General Preparation and Advice before Use

Control Panel – Major Features

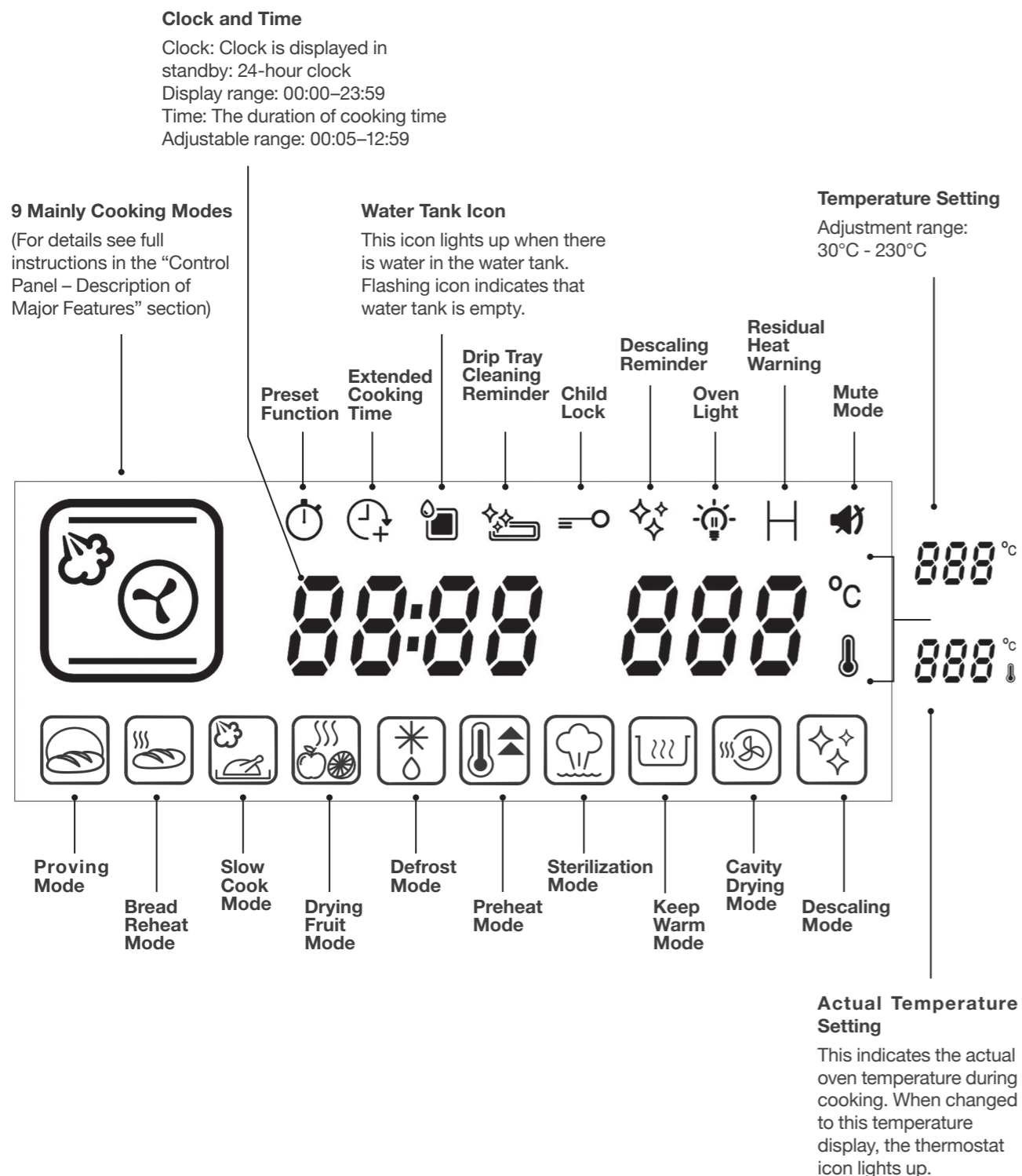







General Preparation and Advice before Use







Control Panel – Description of Major Features

Icon	Mode	Function Descriptions	Default Time/ Temperature	Time/ Temperature Selection Range
	Steam	Steam cooking preserves the original taste, nutrients and color of food cooked. It is suitable for steaming vegetables, meat and seafood or braising soup.	30 minutes / 100°C	Time: 5-419 mins (maximum 6 hours 59 mins) Temperature: 50-110°C
	Turbo Convection	Cooking time is shortened in this mode to bake and roast food quickly. It is suitable for baking large meat and cakes.	30 minutes / 180°C	Time: 5-239 mins (maximum 3 hours 59 mins) Temperature: 100-230°C
	Upper Grill	Suitable for roasting baking-food or at a final stage of roasting or baking. It helps browning the surface of your dish.	30 minutes / 180°C	Time: 5-239 mins (maximum 3 hours 59 mins) Temperature: 100-230°C
	Bottom Grill	Suitable for baking the final stage or for food that needs to be cooked from the bottom periodically during cooking. e.g. pizzas, macaroon.	30 minutes / 180°C	Time: 5-239 mins (maximum 3 hours 59 mins) Temperature: 100-230°C
	Conventional Bake	Traditional single-level baking and grilling mode. Heat is evenly released from the top and bottom. Suitable for cooking meat, fish, etc., and particularly suitable for cakes with moist ingredients at the top.	30 minutes / 180°C	Time: 5-239 mins (maximum 3 hours 59 mins) Temperature: 100-230°C
	Convection	The upper and bottom heater and rear fan operate simultaneously in this mode. Suitable for all baking dishes, such as meat, seafood, pizzas, bread and cookies, pastries and desserts.	30 minutes / 180°C	Time: 5-239 mins (maximum 3 hours 59 mins) Temperature: 100-230°C

General Preparation and Advice before Use

Icon	Mode	Function Descriptions	Default Time/ Temperature	Time/ Temperature Selection Range
	Forced Air	The appliance comes with a rear fan which distributes the hot air produced by the rear heater evenly inside the oven. Food on different levels are heated evenly. It can be used in cooking multiple levels.	30 minutes / 180°C	Time: 5-239 mins (maximum 3 hours 59 mins) Temperature: 100-230°C
	Forced Air + Steam	Cooking food with hot air and steam to prevent moisture loss during high baking temperature. The rear fan produces good circulation of hot air to ensure even heating on multiple levels. This mode is suitable for all types of food.	30 minutes / 180°C	Time: 5-419 mins (maximum 6 hours 59 mins) Temperature: 100-230°C
	Convection + Steam	This mode combines upper, lower heat, hot air and steam cooking. It is a perfect all-in-one combination cooking. Adding steam during the cooking process can prevent moisture loss during high temperature cooking. Suitable for cooking all types of food, such as large cuts of meat or baking moist cakes.	30 minutes / 180°C	Time: 5-419 mins (maximum 6 hours 59 mins) Temperature: 100-230°C
	Proving	This mode works with steam to ensure stable and humidity inside the oven. It allows doughs (for pizzas or bread) to rise quicker in a stable environment, and it used for fermenting pizzas or bread.	30 minutes / 35°C	Time: 5-419 mins (maximum 6 hours 59 mins) Temperature: 30-40°C
	Bread Reheat	Bread is reheated at a regulated temperature and steam is added to reheat bread that tastes just like freshly-baked. Two heating modes are available: Room temperature bread and refrigerated bread.	10 minutes	Time: 5-59 mins Temperature: Cannot be adjusted
	Slow Cook	Steam is injected to maintain temperature inside the oven for slow cooking. Low temperature is used, meat and seafood can be preserved the original flavor without overcooking. Food can be placed in vacuum bags for this mode.	30 minutes / 60°C	Time: 5-419 mins (maximum 6 hours 59 mins) Temperature: 50-90°C

General Preparation and Advice before Use

Icon	Mode	Function Descriptions	Default Time/ Temperature	Time/ Temperature Selection Range
	Drying Fruit	Food is dehydrated with hot air in low heat. Suitable for preparing dried fruit and sliced vegetable or meat jerkies.	60 minutes / 80°C	Time: 5-779 mins (maximum 12 hours 59 mins) Temperature: 40-90°C
	Defrost	Defrost chilled or frozen food.	30 minutes / 55°C	Time: 5-419 mins (maximum 6 hours 59 mins) Temperature: 50-60°C
	Preheat – Steam	Oven is heated to preset temperature by steam.	Present time / 100°C	Temperature: 50-110°C
	Preheat – Baking	Oven is heated to preset temperature by baking function.	Present time / 180°C	Temperature: 100-230°C
	Sterilization	At sterilization mode, high temperature 110°C is used to sterilize dinnerware, cutlery or feeding bottles.	30 minutes / 110°C	Time: 5-419 mins (maximum 6 hours 59 mins) Temperature: 110°C
	Keep Warm	Keeping food warm with hot air. Suitable for keeping cooked dishes warm.	30 minutes / 55°C	Time: 5-239 mins (maximum 3 hours 59 mins) Temperature: 50-60°C
	Cavity Drying	In this mode, the oven is heated to a high temperature so any excessive moisture and steam are evaporated. This function is used for drying the oven after any steam cooking modes.	25 minutes	Time: Cannot be adjusted Temperature: Cannot be adjusted
	Descaling	Descaling icon will be on once combi steamer has reached 100 hours steam related cooking time to remind the user to run descaling programme mode. A descaler is required.	50 minutes	Time: Cannot be adjusted Temperature: Cannot be adjusted

General Preparation and Advice before Use

■ Use and Cooking Tips

1. Minimum time setting is 5 minutes for all cooking modes (Except the "Increase the Cooking Time after Cooking is Completed" function).
2. After cooking is done, the fan will continue to work for 3 minutes for cool down purpose. This is normal.
3. The combi steamer will pause automatically if you open the oven door during cooking. Cooking will continue automatically at the set time and temperature once the door is closed.
4. Take extra care when removing container from the oven after heating, like soup, sauce or beverage. To prevent over boiling, following steps should be taken in cooking liquid.
 - (a) Do not over-heat liquid food. Boiling liquid may splash out and cause scalding when you remove it from the combi steamer.
 - (b) When heating up liquid food, make sure the container is at most 80% full because a small amount of liquid may splash out suddenly when boiled.
 - (c) Stir the liquid before and during heating.
 - (d) Allow the food to stand inside the combi steamer for a while when heating is done. Stir it gently before removing.
 - (e) When using a feeding bottle or heating baby food, stir or shake the food and check the temperature before feeding to avoid burning.
5. Only use a thermometer designed for ovens to check food temperature during cooking, if necessary. If longer cooking time is required, put the food back into the combi steamer to continue cooking.
6. To avoid overheating or over-browning, it is recommended to take the food out when roasting or steaming is finished.
7. To maintain constant temperature during cooking, do not open the oven door unless it is necessary. To avoid affecting oven temperature, do not open the oven door to check food during cooking. If you have opened the oven door, extend the cooking time accordingly.
8. To ensure even browning and cooking, adjust or turn the food's position or direction of the steam or grill plate halfway during heating.
9. Tray Placement Tips
 - For single layer cooking: It's recommended to place a tray on the 3rd layer.
 - For two layers cooking: It's recommended to place a tray on the 2nd and 4th layer.
 - For multi-layers cooking: It's recommended to place a tray on the 2nd, 3rd and 4th layer.

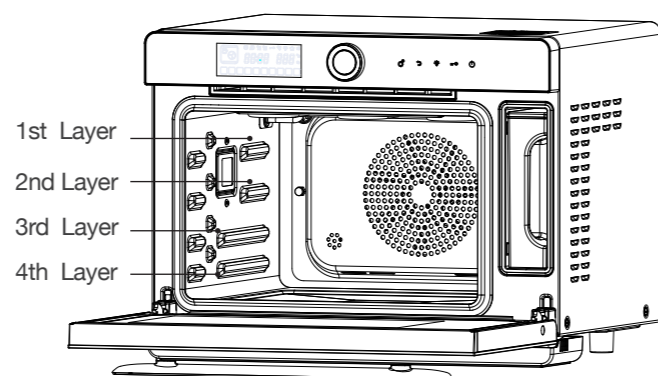

The suggested tray placement above is solely for reference. Tray placement is affected by the quantity, type and shape of food and containers.

General Preparation and Advice before Use

■ Recommended Recipes

Dish	Ingredients	Category	Cooking mode	Temperature	Cooking Time	Pre-heat	Suggested Tray	Tray Placement
Flowering Chinese Cabbage	App.1/2 catty	Vegetable	Steam	110°C	5 mins	Yes	Steam Tray	3rd layer
Steamed egg	1 egg + 2 portions of water	Egg	Steam	100°C	9 mins	Yes	Steam Tray	3rd layer
Steamed rice	120g rice + 120g water	Grain	Steam	100°C	25 mins	No	Steam Tray	3rd layer
Bear's heads, conch and lean pork soup	300g ingredients + 1000g water	Soup	Steam	100°C	180 mins	No	Steam Tray	3rd layer
Steamed minced pork	370g	Meat	Steam	100°C	25 mins	Yes	Steam Tray	3rd layer
Roast chicken thighs	4 chicken thighs	Meat	Convection + Steam	200°C	18 mins	Yes	Grill Rack/ Baking Tray	3rd layer
Minced pork and rice hot pot	150g minced pork + 100g rice + 100g water	Meat + Grain	Convection + Steam	180°C	40 mins	Yes	Grill Rack/ Baking Tray	3rd layer
Muffins with raisins	12 pieces	Bread	Turbo Convection	180°C	22 mins	Yes	Baking Tray	2nd and 4th layer
Round buns	230g	Bread	Turbo Convection	180°C	25 mins	Yes	Baking Tray	3rd layer
Chocolate brownies	6 pieces	Dessert	Convection	180°C	20 mins	Yes	Baking Tray	3rd layer
Macarons	12 pieces	Dessert	Bottom Grill	140°C	15 mins	Yes	Baking Tray	4th layer
Frozen filling bread	1 piece	Bread	Bread Reheat mode 1	Default	12 mins	No	Grill Rack/ Baking Tray	3rd layer
Room temperature filling bread	1 piece	Bread	Bread Reheat mode 2	Default	10 mins	No	Grill Rack/ Baking Tray	3rd layer
Frozen bread	1 piece	Bread	Bread Reheat mode 1	Default	10 mins	No	Grill Rack/ Baking Tray	3rd layer
Room temperature bread	1 piece	Bread	Bread Reheat mode 2	Default	8 mins	No	Grill Rack/ Baking Tray	3rd layer

The suggested cooking time above is solely for reference. Cooking time and results are affected by the preferred degree of doneness, starting temperature as well as the quantity, size and shape of food and containers.

Operation Instructions

■ Setting the Clock

When the appliance is first powered on, it will beep and returned to standby mode. The default clock display is 12:00. The display panel lights up completely.



The combi steamer returned to energy saving mode if no button is pressed or door is opened for 5 minutes. Under energy saving mode, display will be turned off, only the power button can be used. Press the power button to exit the energy saving mode and back to the startup screen.

Example: Set the clock to the current time 13:20.

Steps:

1. On the standby screen, press and hold the setting button  for 3 seconds. The hour digits flash.
(as shown in the diagram below)



2. Set the hour by turning the knob. When the hour reaches 13, press the knob to confirm.
(as shown in the diagram below) The display will change to the minute setting automatically. The minute digits flash.



3. Set the minute by turning the knob. When the minute reaches 20, press the knob to confirm.
(as shown in the diagram below)



4. Time setting is complete. (as shown in the diagram below)



Important: If no action is taken within 5 minutes during the setting process, all settings will be cancelled and the display will return to the standby screen. The combi steamer is in standby.

Operation Instructions

■ Steam Mode

Steam cooking preserves the original taste, nutrients and color of food. It is suitable for steaming vegetables, meat and seafood or braising soup. Always ensure the water tank is filled before using this mode.

	Temperature	Time
Default Setting	100°C	30 mins
Setting Range	50°C - 110°C	5 mins - 6 hours and 59 mins

Example: Set the cooking time to 1 hour and 40 minutes; cooking temperature is 90°C.

Steps:

1. In standby mode, turn the knob clockwise to  Steam Mode. The icon will flash. Press the knob to confirm (as shown in the diagram below). The display will jump to hour setting automatically.



2. Turn the knob until the hour display shows 01. Press the knob to confirm (as shown in the diagram below). The display will jump to minute setting automatically.



3. Turn the knob until the minute display shows 40. Press the knob to confirm (as shown in the diagram below). The display will jump to temperature setting automatically.



4. Turn the knob until the temperature display shows 90°C. Press the knob to confirm (as shown in the diagram below).



5. Setting is complete. The combi steamer will start cooking.

Operation Instructions

■ Turbo Convection Mode

Cooking time is shortened in this mode to bake and roast food quickly. It is suitable for baking large meat and cakes. It is recommended to place aluminum foil or baking paper onto the baking tray before cooking.

	Temperature	Time
Default Setting	180°C	30 mins
Setting Range	100°C - 230°C	5 mins - 3 hours and 59 mins

Example: Set the cooking time to 40 minutes; cooking temperature is 210°C.

Steps:

1. In standby mode, turn the knob clockwise to  Turbo Convection Mode. The icon will flash. Press the knob to confirm (as shown in the diagram below). The display will jump to hour setting automatically.



2. Press the knob to confirm the 00 hour setting. (as shown in the diagram below). The display will jump to minute setting automatically.



3. Turn the knob until the minute display shows 40. Press the knob to confirm (as shown in the diagram below). The display will jump to temperature setting automatically.



4. Turn the knob until the temperature display shows 210°C. Press the knob to confirm (as shown in the diagram below).



5. Setting is complete. The combi steamer will start cooking.

Operation Instructions

■ Upper/ Bottom Grill/ Conventional Bake Mode

Three grill modes are available: upper grill, bottom grill and conventional bake (upper and bottom grill). You can select a suitable mode according to the types of food and cooking result that you are looking for. It is recommended to place aluminum foil or baking paper onto the baking tray before cooking.

Upper Grill Mode: Suitable for roasting baking food or at a final stage of roasting or baking. It helps browning the surface of your dish.

Bottom Grill Mode: Suitable for baking in the final stage or for food that needs to be cooked from the bottom periodically during cooking, e.g. pizzas, macaroon.

Conventional Mode: Traditional single-level baking and grilling mode. Heat is evenly released from the top and bottom. Suitable for cooking meat, fish, etc., and particularly suitable for cakes with moist ingredients at the top.

	Temperature	Time
Default Setting	180°C	30 mins
Setting Range	100°C - 230°C	5 mins - 3 hours and 59 mins

Example: Set the cooking time to 40 minutes; cooking temperature is 210°C.

Steps:

1. In standby mode, turn the knob clockwise to  or  or  Mode. Icon of the selected grill mode will flash. Press the knob to confirm (as shown in the diagram below). The display will jump to hour setting automatically.



2. Press the knob to confirm the 00 hour setting (as shown in the diagram below). The display will jump to minute setting automatically.



3. Turn the knob until the minute display shows 40. Press the knob to confirm (as shown in the diagram below). The display will jump to temperature setting automatically.



4. Turn the knob until the temperature display shows 210°C. Press the knob to confirm (as shown in the diagram below).



5. Setting is complete. The combi steamer will start cooking.

Operation Instructions

■ Convection Mode

The upper and lower heaters and rear fan operate simultaneously in this mode. Suitable for all baking dishes, such as meat, seafood, pizzas, bread and cookies, pastries and desserts. It is recommended to place aluminum foil or baking paper onto the baking tray before cooking.

	Temperature	Time
Default Setting	180°C	30 mins
Setting Range	100°C - 230°C	5 mins - 3 hours and 59 mins

Example: Set the cooking time to 40 minutes; cooking temperature is 210°C.

Steps:

1. In standby mode, turn the knob clockwise to  Convection Mode. The icon will flash. Press the knob to confirm (as shown in the diagram below). The display will jump to hour setting automatically.



2. Press the knob to confirm the 00 hour setting (as shown in the diagram below). The display will jump to minute setting automatically.



3. Turn the knob until the minute display shows 40. Press the knob to confirm (as shown in the diagram below). The display will jump to temperature setting automatically.



4. Turn the knob until the temperature display shows 210°C. Press the knob to confirm (as shown in the diagram below).



5. Setting is complete. The combi steamer will start cooking.

Operation Instructions

■ Forced Air Mode

The appliance comes with a rear fan which distributes the hot air produced by the rear heater evenly inside the oven. Foods on different levels are heated evenly. It can be used in cooking multiple levels. It is recommended to place aluminum foil or baking paper onto the baking tray before cooking.

	Temperature	Time
Default Setting	180°C	30 mins
Setting Range	100°C - 230°C	5 mins - 3 hours and 59 mins

Example: Set the cooking time to 40 minutes; cooking temperature is 210°C.

Steps:

1. In standby mode, turn the knob clockwise to  Forced Air Mode. The icon will flash. Press the knob to confirm (as shown in the diagram below). The display will jump to hour setting automatically.



2. Press the knob to confirm the 00 hour setting (as shown in the diagram below). The display will jump to minute setting automatically.



3. Turn the knob until the minute display shows 40. Press the knob to confirm (as shown in the diagram below). The display will jump to temperature setting automatically.



4. Turn the knob until the temperature display shows 210°C. Press the knob to confirm (as shown in the diagram below).



5. Setting is complete. The combi steamer will start cooking.

Operation Instructions

■ Forced Air + Steam Mode

Cooking food with hot air and steam to prevent moisture loss during high temperature cooking. The rear fan provides good circulation of hot air to ensure even heating on multiple levels. This mode is suitable for all types of food. It is recommended to place aluminum foil or baking paper onto the baking tray before cooking. Always ensure the water tank is filled before using this mode.

	Temperature	Time
Default Setting	180°C	30 mins
Setting Range	100°C - 230°C	5 mins - 6 hours and 59 mins

Example: Set the cooking time to 40 minutes; cooking temperature is 210°C.

Steps:

1. In standby mode, turn the knob clockwise to  Forced Air + Steam Mode. The icon will flash. Press the knob to confirm (as shown in the diagram below). The display will jump to hour setting automatically.



2. Press the knob to confirm the 00 hour setting (as shown in the diagram below). The display will jump to minute setting automatically.



3. Turn the knob until the minute display shows 40. Press the knob to confirm (as shown in the diagram below). The display will jump to temperature setting automatically.



4. Turn the knob until the temperature display shows 210°C. Press the knob to confirm (as shown in the diagram below).



5. Setting is complete. The combi steamer will start cooking.

Operation Instructions

■ Convection + Steam Mode

This mode combines upper, lower heat, hot air and steam cooking. It is a perfect all-in-one combination cooking. Adding steam during the cooking process can prevent moisture loss during high temperature cooking. Suitable for cooking all types of food, such as large cuts of meat or baking moist cakes. It is recommended to place aluminum foil or baking paper onto the baking tray before cooking. Always ensure that the water tank is filled before using this mode.

	Temperature	Time
Default Setting	180°C	30 mins
Setting Range	100°C - 230°C	5 mins - 6 hours and 59 mins

Example: Set the cooking time to 40 minutes; cooking temperature is 210°C.

Steps:

1. In standby mode, turn the knob clockwise to  Convection + Steam Mode. The icon will flash. Press the knob to confirm (as shown in the diagram below). The display will jump to hour setting automatically.



2. Press the knob to confirm the 00 hour setting (as shown in the diagram below). The display will jump to minute setting automatically.



3. Turn the knob until the minute display shows 40. Press the knob to confirm (as shown in the diagram below). The display will jump to temperature setting automatically.



4. Turn the knob until the temperature display shows 210°C. Press the knob to confirm (as shown in the diagram below).



5. Setting is complete. The combi steamer will start cooking.

Operation Instructions

■ Proving Mode

This mode works with steam to ensure stable high temperature and humidity inside the oven. It allows dough (for pizza or bread) to rise quicker in a stable environment, and is used for fermenting dough for pizzas or bread. Always ensure that the water tank is filled before using this mode.

	Temperature	Time
Default Setting	35°C	30 mins
Setting Range	30°C - 40°C	5 mins - 6 hours and 59 mins

Example: Set the cooking time to 40 minutes; cooking temperature is 35°C.

Steps:

1. In standby mode, turn the knob clockwise to  Proving Mode. The icon will flash. Press the knob to confirm (as shown in the diagram below). The display will jump to hour setting automatically.



2. Press the knob to confirm the 00 hour setting (as shown in the diagram below). The display will jump to minute setting automatically.



3. Turn the knob until the minute display shows 40. Press the knob to confirm (as shown in the diagram below). The display will jump to temperature setting automatically.



4. Turn the knob to confirm the 35°C temperature setting (as shown in the diagram below).



5. Setting is complete. The combi steamer will start cooking (as shown in the diagram below).



Operation Instructions

■ Bread Reheat Mode

Bread is reheated at a regulated temperature and steam is added to reheat bread that tastes just like freshly-baked. Two heating modes are available: Room temperature bread and refrigerated bread. Always ensure that the water tank is filled before using this mode.

Suggested cooking time: Reheating time for frozen bread: about 10-15 minutes; Reheating time for room temperature bread: about 8-13 minutes. It is recommended to add 5-10 minutes for bread with fillings. This suggested cooking time is solely for reference. Cooking time is affected by the bread's quantity, size, type and personal taste.

	Temperature	Time
Default Setting	10 mins	"1" Refrigerated bread
Setting Range	5 - 59 mins	"1" Refrigerated bread / "2" Room temperature bread

Example: Cooking bread that has been refrigerated. Set the cooking time to 25 minutes

Steps:

1. In standby mode, turn the knob clockwise to  Bread Reheat Mode. The icon will flash. Press the knob to confirm (as shown in the diagram below). The display will jump to minute setting automatically.



2. Turn the knob until the minute display shows 25. Press the knob to confirm (as shown in the diagram below). The display will jump to mode options automatically.



3. The combi steamer will enter bread type options. Default option is "1", refrigerated bread reheat mode. Press the knob to confirm (as shown in the diagram below).



If you wish to change the mode, turn the knob until mode "2" is displayed if necessary. Press the knob to confirm.

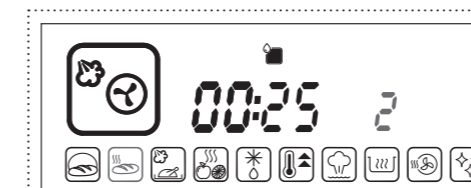

4. Setting is complete. The combi steamer will start cooking (as shown in the diagram below).

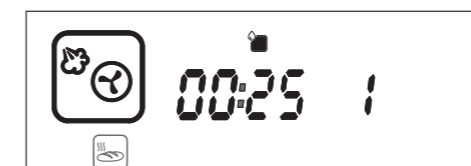

Important: The function of "Combination Button: Cavity temperature display" is not available in this mode.

Operation Instructions

■ Slow Cook Mode

Steam is injected to maintain temperature inside the oven for slow cooking. Low temperature is used, meat and seafood can be preserved the original flavor without overcooking. Food can be placed in vacuum bags. Always ensure that the water tank is filled before using this mode.

	Temperature	Time
Default Setting	60°C	30 mins
Setting Range	50°C - 90°C	5 mins - 6 hours and 59 mins

Example: Set the cooking time to 40 minutes; cooking temperature is 60°C.

Steps:

1. In standby mode, turn the knob clockwise to  Slow Cook Mode. The icon will flash. Press the knob to confirm (as shown in the diagram below). The display will jump to hour setting automatically.



2. Press the knob to confirm the 00 hour setting (as shown in the diagram below). The display will jump to minute setting automatically.



3. Turn the knob until the minute display shows 40. Press the knob to confirm (as shown in the diagram below). The display will jump to temperature setting automatically.



4. Press the knob to confirm 60°C temperature setting. (as shown in the diagram below).



5. Setting is complete. The combi steamer will start cooking (as shown in the diagram below).



Operation Instructions

■ Drying Fruit Mode

Food is dehydrated with hot air in low heat. Suitable for preparing dried fruit and vegetable slices or meat jerkies.

	Temperature	Time
Default Setting	80°C	60 mins
Setting Range	40°C - 90°C	5 mins - 12 hours and 59 mins

Example: Set the cooking time to 2 hours; cooking temperature is 90°C.

Steps:

1. In standby mode, turn the knob clockwise to  Drying Fruit Mode. The icon will flash. Press the knob to confirm (as shown in the diagram below). The display will jump to hour setting automatically.

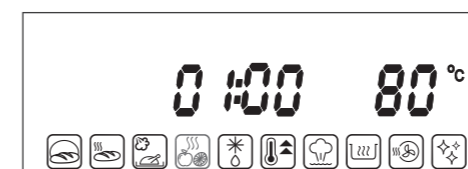

2. Turn the knob until the hour display shows 02. Press the knob to confirm (as shown in the diagram below). The display will jump to minute setting automatically.



3. Press the knob to confirm the 00 minute setting (as shown in the diagram below). The display will jump to temperature setting automatically.



4. Turn the knob until the temperature display shows 90°C. Press the knob to confirm (as shown in the diagram below).



5. Setting is complete. The combi steamer will start cooking (as shown in the diagram below).

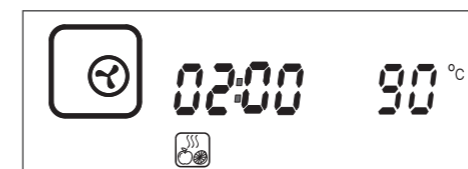

Operation Instructions

■ Defrost Mode

Defrost chilled or frozen food with steam. Always ensure that the water tank is filled before using this mode.

	Temperature	Time
Default Setting	55°C	30 mins
Setting Range	50°C - 60°C	5 mins - 6 hours and 59 mins

Example: Set the cooking time to 1 hour and 40 minutes; defrosting temperature is 60°C.

Steps:

1. In standby mode, turn the knob clockwise to  Defrost Mode. The icon will flash. Press the knob to confirm (as shown in the diagram below). The display will jump to hour setting automatically.



2. Turn the knob until the hour display shows 01. Press the knob to confirm (as shown in the diagram below). The display will jump to minute setting automatically.



3. Turn the knob until the minute display shows 40. Press the knob to confirm (as shown in the diagram below). The display will jump to temperature setting automatically.



4. Turn the knob until the temperature display shows 60°C. Press the knob to confirm (as shown in the diagram below).



5. Setting is complete. The combi steamer will start cooking (as shown in the diagram below).

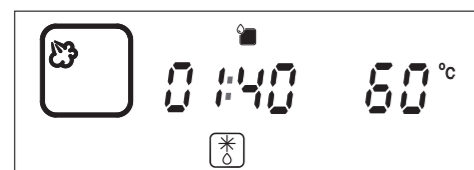

Operation Instructions

■ Preheat Mode

The Preheat Mode can be operated with steam or baking mode. The oven will be heated to preset temperature.

	Steam Preheating	Baking Preheating
	Temperature	Temperature
Default Setting	100°C	180°C
Setting Range	50°C - 110°C	100°C - 230°C

Oven will automatically adjust the cooking time according to set temperature. "END" will be displayed and an audio tone will be heard when the temperature reaches the preset temperature. Current time is displayed during preheating. Always ensure that the water tank is filled before using steam preheating.

Example: Set the steam preheating temperature to 100°C.

Steps:

1. In standby mode, turn the knob clockwise to  Preheat Mode. The icon will flash. Steam is the default setting. Press the knob to confirm (as shown in the diagram below).



2. The display will jump to temperature setting automatically. Press the knob to confirm the default temperature 100°C (as shown in the diagram below).



3. Setting is complete. The combi steamer will start preheating (as shown in diagram below).



Operation Instructions

Example: Set the baking preheating temperature to 200°C.

Steps:

1. In standby mode, turn the knob clockwise to Preheating Mode. The icon will flash. Steam is the default setting. Turn the knob to select the baking preheating mode, and then press the knob to confirm (as shown in the diagram below).



2. The display will jump to temperature setting automatically. Turn the knob until the display shows 200°C. Press the knob to confirm (as shown in the diagram below).



3. Setting is complete. The combi steamer will start preheating (as shown in the diagram below).



When preheating is complete, the display will show "END" and an audio tone will be heard (as shown in the diagram below). After preheating the combi steamer, you can select other cooking modes to continue your cooking as required.



Important: The function of "Adjust or Increase the Cooking Time during/after Cooking is Completed" is not available in this mode.

Operation Instructions

■ Sterilization Mode

At sterilizing mode, high temperature 110°C is used to sterilize dinnerware, cutlery or feeding bottles. Always ensure that the water tank is filled before using this mode.

	Temperature	Time
Default Setting	110°C	30 mins
Setting Range	Cannot be adjusted	5 mins - 6 hours and 59 mins

Example: Set the cooking time to 35 minutes.

Steps:

1. In standby mode, turn the knob clockwise to  Sterilization Mode. The icon will flash. Press the knob to confirm (as shown in the diagram below). The display will jump to hour setting automatically.



2. Turn the knob to confirm the 00 hour setting (as shown in the diagram below). The display will jump to minute setting automatically.



3. Turn the knob until the minute display shows 35. Press the knob to confirm (as shown in the diagram below).



4. Setting is complete. The combi steamer will start cooking (as shown in the diagram below).



Operation Instructions

■ Keep Warm Mode

Keeping food warm with hot air. Suitable for keeping cooked dishes warm.

	Temperature	Time
Default Setting	55°C	30 mins
Setting Range	50°C - 60°C	5 mins - 3 hours and 59 mins

Example: Set the cooking time to 1 hours and 30 minutes; cooking temperature is 60°C.

Steps:

1. In standby mode, turn the knob clockwise to  Keep Warm Mode. The icon will flash. Press the knob to confirm (as shown in the diagram below). The display will jump to hour setting automatically.



2. Turn the knob until the hour display shows 01. Press the knob to confirm (as shown in the diagram below). The display will jump to minute setting automatically.



3. Press the knob to confirm the "30" minute setting (as shown in the diagram below). The display will jump to temperature setting automatically.



4. Turn the knob until the temperature display shows 60°C. Press the knob to confirm (as shown in the diagram below).



5. Setting is complete. The combi steamer will start cooking (as shown in the diagram below).

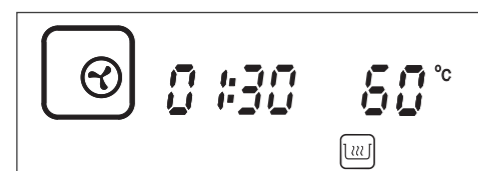

Operation Instructions

■ Cavity Drying Mode

In this mode, the oven is heated to a high temperature so any excessive moisture and steam are evaporated. This function is used for drying the oven after any steam cooking modes.

	Temperature	Time
Default Setting	Cannot be adjusted	25 mins
Setting Range	Cannot be adjusted	Cannot be adjusted

Steps:

1. In standby mode, turn the knob clockwise to  Cavity Drying Mode. The icon will flash. Press the knob to confirm (as shown in the diagram below).



2. The combi steamer will start cooking (as shown in the diagram below).





Important:

1. The function of "Combination Button: Cavity temperature display" is not available in this mode.
2. The function of "Adjust or Increase the Cooking Time during/after Cooking is Completed" is not available in this mode.

■ Descaling Mode

Water used in steaming mode may result in scale inside cavity and water pipe.

“Descaling” icon  will be on once combi steamer has reached 100hrs steam related cooking time to remind the user to run the descaling programme mode. The light will stay on until the descaling is performed.

Descaling is carried out in three stages that involve one descaling process and two descaling and cleaning processes. The user has to change the liquid in the tank 3 times during the entire cleaning process. It is also necessary to empty the drip tray by cleaning up. Icon  will be lighted to remind cleaning up the drip tray is needed. Also, descaler is required for this mode. For satisfactory results, follow the suggested dosage for descaler and water below:

Stage 1: Descaling. Running time is 30 minutes. Suggested dosage: 50ml descaling agent and 500ml water.



Stage 2: 1st descaling and cleaning process. Running time is 10 minutes. Suggested dosage: 550ml pure water.

Stage 3: 2nd descaling and cleaning process. Running time is 10 minutes. Suggested dosage: 550ml pure water.

	Temperature	Time
Default Setting	Cannot be adjusted	50 mins
Setting Range	Cannot be adjusted	Cannot be adjusted

Steps:

1. Stage 1: Descaling

- Fill the water tank up to the level of the descaling icon  with 50ml descaling agent and 500ml pure water.
- In standby mode, turn the knob clockwise to  Descaling Mode. The icon will flash. Press the knob to confirm (as shown in the diagram below).





- The descaling mode will start (as shown in the diagram below).





- Stage 1 takes 30 minutes. When done, the time display digits will flash and an audio tone will sound to indicate stage 1 is complete.  Drip tray cleaning reminder icon will light up on the display panel to remind the user to empty the drip tray.
- Pour out the dirty liquid and put the drip tray back into place.

2. Stage 2: 1st descaling and cleaning process

- Open the oven door, fill the water tank up to the level of the descaling icon  with 550ml pure water.
- Put the water tank back into place and close the oven door. Descaling and cleaning will begin automatically.
- When done, the time display digits will flash and an audio tone will sound to indicate stage 2 is complete.  Drip tray cleaning reminder icon will light up on the display panel to remind the user to empty the drip tray.
- Pour out the dirty liquid and put the drip tray back into place.

3. Stage 3: 2nd descaling and cleaning process

- Open the oven door. Fill the water tank up to the level of the descaling icon  with 550ml pure water.
- Put the water tank back into place and close the oven door. Descaling and cleaning will begin automatically.
- When done, the display will show “END” and an audio tone will sound.  Drip tray cleaning reminder icon will light up on the display panel to remind the user to empty the drip tray.
- Pour out the dirty liquid and put the drip tray back into place.

4. Descaling is complete.

Important:

- The function of “Combination Button: Cavity temperature display” is not available in this mode.
- The function of “Adjust or Increase the Cooking Time during/after Cooking is Completed” is not available in this mode.
- Descaling mode will be interrupted if the steps of descaling mode is taken in the wrong way (including pause during the descaling process or open and close the oven door not following instructions etc). Please restart descaling mode and follow the instructions in the manual.

■ Preset Function

You must set the clock before using the preset function. For instructions on clock setting, please see “Setting the Clock” on page 60 of this instruction manual.

Example: The current time is 16:30. You want to preset cooking time for the Bottom Grill Mode. Cooking time is 40 minutes and temperature is 210°C. Cooking will stop at 18:00.

Steps:

1. In standby mode, turn the knob clockwise  Bottom Grill Mode. The icon will flash. Press the knob to confirm (as shown in the diagram below). The display will jump to hour setting automatically.



2. Press the knob to confirm the 00 hour setting (as shown in the diagram below). The display will jump to minute setting automatically.



3. Turn the knob until the minute display shows 40. Press the knob to confirm (as shown in the diagram below). The display will jump to temperature setting automatically.



4. Turn the knob until the temperature display shows 210°C. Press the setting button  to confirm (as shown in the diagram below).



5. The screen for presetting the finishing time will be seen. The clock will go back to current time display, i.e. 16:30. The “16” digits will flash. The  preset function icon at the top of the display panel will also flash to indicate preset setting is in process (as shown in the diagram below).



6. Turn the knob until the hour display shows 18. Press the knob to confirm (as shown in the diagram below). The display will jump to minute setting automatically.

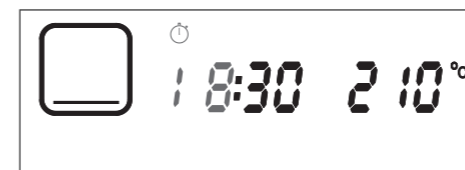



7. Turn the knob until the minute display shows 00. Press the knob to confirm.



8. The  preset function icon of the display panel will flash. Display will change from operating time back to the current time 16:30, indicating preset setting is complete (as shown in the diagram below).



A. Checking Preset Function Status

Press and hold the setting button  for 3 seconds to check the preset stop time. The preset function icon will flash. Press and hold the setting button  for 3 seconds again to return to the preset function screen.

B. Cancelling Preset Function:

To cancel any preset function setting, press the  power button directly. The combi steamer will return to the standby screen automatically.

Important: Preset Function is available in 9 Mainly Cooking Modes, Bread Reheat Mode, Slow Cook Mode and Drying Fruit Mode. (See “Control Panel – Major Features/ Description of Major Features on P.54-57 for details)

Suggestion: Preset cooking operation may be cancelled if children touch the screen accidentally. To avoid this, activate the child lock function after setting the preset function. For instructions on setting the child lock, please see “Control Panel – Basic Functions” on page 52 of this instruction manual. The child lock will not affect cooking. The combi steamer will start cooking normally at the preset time.

Operation Instructions

■ Adjust or Increase the Cooking Time during/after Cooking is Completed

A. Adjust the cooking time during cooking process



You can extend or shorten the cooking time and the temperature as required during the cooking process.

Example: Change the cooking time and temperature settings from 01:40 and 90°C to 02:00 and 100°C.

Steps:

1. During cooking, press the knob to interrupt and pause the cooking. The time display will flash (as shown in the diagram below).



2. Press the setting button . The display will go to the reset cooking time screen automatically. The hour digit flashes, and the  “Extended Cooking Time” icon lights up on the display (as shown in the diagram below).



3. Turn the knob until the hour display shows 02. Press the setting button  to confirm (as shown in the diagram below). The display will jump to minute setting automatically.



4. Turn the knob until the minute display shows 00. Press the setting button  to confirm (as shown in the diagram below). The display will jump to temperature setting automatically.



5. Turn the knob until the temperature display shows 100°C. Press the knob to confirm (as shown in the diagram below).



6. Setting is complete. Cooking will be resumed with new settings (as shown in the diagram below).





Operation Instructions

B. Increase the cooking time after cooking is completed

You can increase the cooking time after cooking is completed. Temperature cannot be adjusted.

	Temperature	Time
Setting Range	Cannot be adjusted	1 – 59 mins

When cooking is completed, the “END” will be shown on display and an audio tone sounds. The  “Extended Cooking Time” icon will light up on the display and the  “drip tray cleaning reminder” icon will flash for 3 minutes. (Note: the drip tray cleaning reminder icon will light up only if the steam mode has been in operation) (As shown in the diagram below).



To increase the cooking time, follow the steps below:

Example: Cooking is completed and need to increase the cooking time by 3 minutes.

Steps:

1. Press the knob to confirm to increase the cooking time, the display will jump to minute setting automatically.



2. Turn the knob until the minute display shows 03. Press the knob to confirm (as shown in the diagram below).



3. Setting is complete. Cooking will resume with added cooking time under previous settings (as shown in the diagram below).



Note: If no action is taken within 3 minutes after cooking is completed, the combi steamer will return to standby mode.

■ Residual Heat Indicator

In standby or energy-saving mode the  “Residual Heat Indicator” icon will be shown to warn that cavity exceed 50°C and is not suitable for cleaning (as shown in the diagram below). The icon will be off until cavity drops below 50°C. Users should not clean the appliance until the icon is off.



■ Child Lock

Steamer is equipped with child lock so that children cannot switch on or change any setting accidentally.

A. Activating the Child Lock:

Press and hold the  “Child Lock” button for 3 seconds. Child lock is enabled. The “Child Lock” icon lights up (as shown in the diagram below).

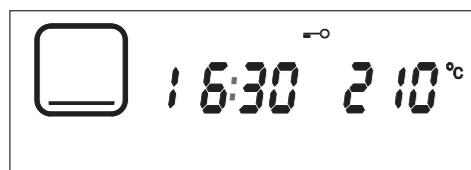

B. Cancelling the Child Lock:

Press and hold the “Child Lock” button for 3 seconds to disable the child lock function. The “Child Lock” icon goes off.

■ Cleaning and Maintenance

- Under normal circumstances, cleaning is the only maintenance required.
- Cleaning and maintenance should only be carried out when the combi steamer is cool and the  Residual Heat Indicator icon disappeared. Disconnect the power plug from the main power supply before cleaning. Do not use any steam cleaner to clean this appliance.
- To avoid corrosion which would shorten the useful life of your combi steamer, always keep it clean. Always clean the appliance after use.
- To avoid damage to the combi steamer body, control panel, oven walls and accessories, do not use any cleaning cloth that contains metal, scrubbing cleaners, steel brush or cloth with a rough surface for cleaning. Use a sponge or cloth soaked in gentle detergent or kitchen towel paper sprayed with glass cleaner to clean the appliance. Always make sure the cavity (including the bottom) is completely dried after use.
- Salt is a corrosive substance that would result in rust stains if left to build up inside the oven. Acidic sauces, such as ketchup, mustard and preserves, contain chemicals like chlorine and acids which would damage the stainless steel surface.
- Do not allow grease and food debris to remain on the oven door and door seal. If the door seal is not kept clean, the oven door may fail to close when the appliance is in operation. This would cause damage to the front and sides of the combi steamer.
- After each use:
 - Empty the black drip tray under the oven door to prevent overflow, splash and soiling of the worktop. (The drip tray can be removed. It collects condensation water every time after use when door is opened)
 - Empty the water tank.
 - Always leave the door opened for 15-30 minutes or run the Cavity Drying Mode to dry the oven and door frame.
- If the oven is very dirty, run the Sterilization Mode (110°C) to remove grease and dirt with steam for 30 minutes before cleaning. Do not start cleaning until the appliance has cooled down. For stubborn grease stains, repeat these steps several times. Never use any cleaning cloth that contains metal, scrubbing cleaners, steel brush or cloth with a rough surface for cleaning.
- It is suggested to run the Descaling Mode at least once a month or when the descaling icon lights up.
- Tap water, drinking water or distilled water is suggested for steaming function. Avoid using mineral water.
- The water tank must be checked at least once a month. Clean it if necessary and put it back correctly.
- Disconnect the main power if the appliance will not be used for a long period. Keep the oven clean and put the appliance in a dry place away from corrosive gases.
- After every use, clean and air dry the oven (including the top, sides and bottom). If discoloration is detected at the bottom or inside the oven, remove the stains with a stainless steel cleaner (e.g. Wpro Steel Cleaner).

■ How to Remove the Back Panel

A. Dismantling the Back Panel

1. With the socket tool, turn anticlockwise to remove the screw. Dismantle the back panel (as shown in the diagram below).

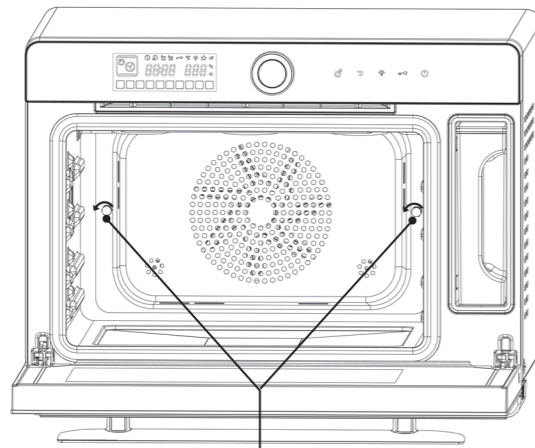

With the socket tool, turn anticlockwise to remove the screw.

2. Clean the back panel (as shown in the diagram below).

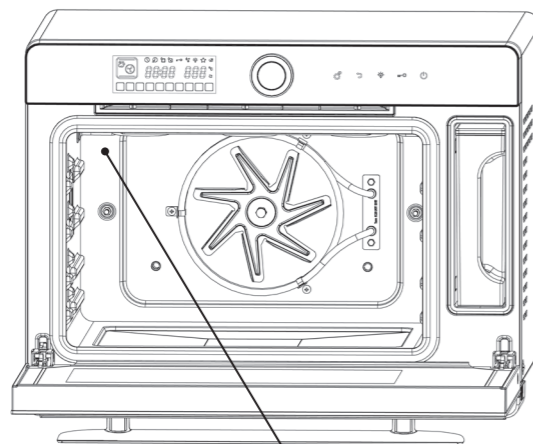

After dismantling the back panel, clean the rear oven plate and back panel.

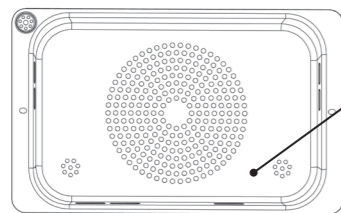

B. Assembly the Back Panel

Put the back panel inside the oven, matching the screw holes in the rear plate. Insert the 2 original screws and turn clockwise until tight and secure.

Important: Exercise caution during the whole process to avoid cutting your hands or scratching the oven surface.

■ How to Lower the Upper Heater

1. Put your thumbs on heater's mounting stainless steel bracket (left and right side of the round nut). Push back gently towards the arrow position as shown below.

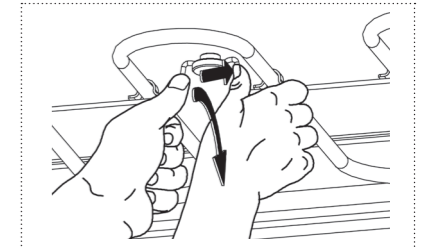
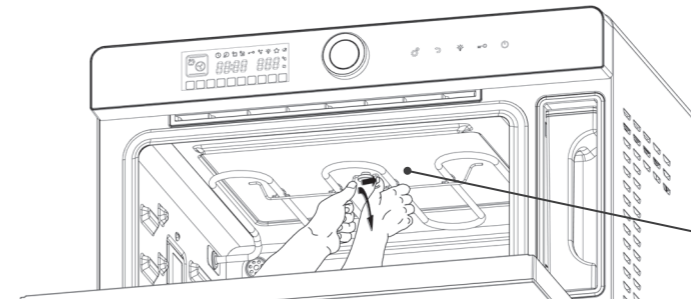

Put your thumbs on heater's mounting stainless steel bracket (left and right side of the round nut) and push back gently. The heater will be lowered.

2. You can clean the top of the oven now (as shown in the diagram below).

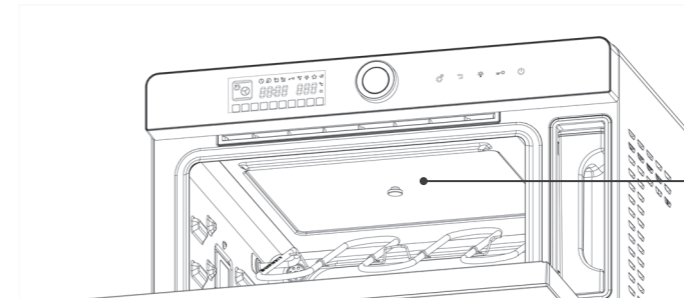

The heater will be lowered for easy cleaning.

3. After cleaning, gently press the upper heater backwards to snap into place.

Important:

1. Both thumbs and gentle force is required to press backwards for the steel bracket to easily lock into place.
2. Cleaning should only be carried out when the combi steamer is cool and the  Residual Heat Indicator icon is disappeared.

■ Troubleshooting

A. Possible Problems

	Problem	Cause	Solution
1	No Display	Combi steamer is not connected to power supply	Ensure it is connected to power supply
		Malfunction of power socket	Check if other electrical appliances work normally
		Power cords is not working	Contact after-sales service
2	Combi steamer is not working	Power supply plug is not connected correctly	Try to plug in the power supply again
		Oven door is not closed properly	Close the oven door again
		Water tank is not in a correct position	Put the water tank back correctly
		Circuit board is damaged	Contact after-sales service
3	Display is not working properly	Child lock is enabled	Disable the child lock
		Display is damaged	Contact after-sales service
	Circuit board is damaged		
4	Lots of Water or steam can be found during cooking	Door seal is damaged	Contact after-sales service
		Oven door is not closed tightly	Close the oven door tightly again
5	Oven light is not working	Light is damaged	Contact after-sales service
		Control board is damaged	
6	Fan motor fails to work properly	Fan motor is damaged	Contact after-sales service
		Control board is damaged	
7	Control panel is not working properly	Control panel is out of order	Contact after-sales service
		Control board is damaged	
8	No steam	Water tube is damaged	Contact after-sales service
		Water pump is damaged	
		Water tank is empty or not in place	
9	Water leakage	The water tank is not in a correct position	Fill the water tank and put it back correctly

B. Following conditions are normal

	Condition	Cause
1	Fame and smell can be detected during the first time of use	These are emitted by the protective oil and it is normal.
2	Noise can be heard using any steam related mode	This is normal during water pumping into machine for steaming.
3	Water condensation can be found around the ventilation vent or door	The combi steamer produces a large amount of steam under steam cooking mode. Most of the steam will be vented from the frontal ventilation and some condensation water will be found around the ventilation vent.
4	The fan continues to work after cooking is finished	The fan will continue to run for 3 minutes after each cooking mode for cooling purpose to discharge oven heat completely. It is normal.
5	White powder can be found around the air inlet	This is water scale. It is normal. If white powder (water scale) is detected, it is recommended to run the Descaling Mode for cleaning purpose.
6	Bottom and cavity of oven's color has yellowing.	Stainless steel will generate yellow marks when heated and not kept clean. It is recommended to clean the combi steamer after each use to avoid the yellowing issue caused.

■ Product Specifications

Model	CS2320
Rated Voltage and Frequency	220~240V / 50~60Hz
Rated Input Power	2100W
Product Dimension (H x W x D)	405 x 530 x 457 mm
Cavity Dimension (H x W x D)	244 x 387 x 342 mm
Oven Capacity	32L
Net Weight	Approximately 25 kg



星級服務 STAR SERVICE

查詢熱線 Star Hotline

香港 Hong Kong : 2406 9138

澳門 Macau : 0800157

送貨查詢熱線 Delivery Hotline : 2407 3126

