

Whirlpool

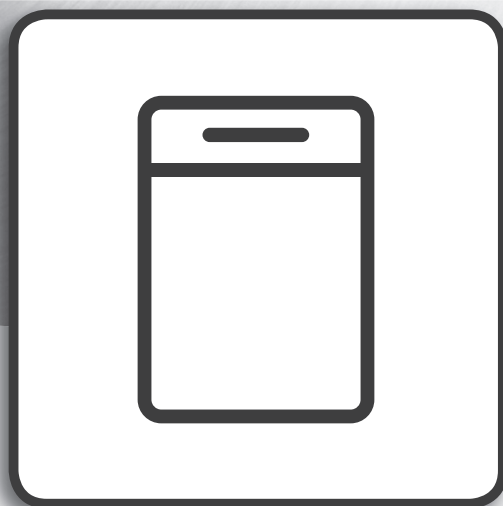

User Manual

使用說明書

Model : WSFE2B19UK

產品型號 : WSFE2B19UK



www.whirlpool.com.hk

ENGLISH 3

繁體中文 16

USER MANUAL



THANK YOU FOR BUYING A WHIRLPOOL PRODUCT.

In order to receive a more complete assistance,
please register your appliance on www.whirlpool.com.hk

INDEX

| | |
|---|--------------|
| USER MANUAL | 3 |
| Product Description | 4 |
| Appliance | 4 |
| Control Panel | 4 |
| First Time Use (Salt, Rinse Aid and Detergent) | 5 |
| Programs Table | 6 |
| Programs Description | 6 |
| Options and Functions | 7 |
| Loading the Racks | 8 |
| Daily Use | 9 |
| Advice and Tips | 9 |
| Care and Maintenance | 10 |
| Cleaning the filter assembly | 10 |
| Cleaning the spray arms | 10 |
| Cleaning the water inlet hose | 10 |
| Troubleshooting | 11 |
| Health & Safty Guide | 12-13 |
| Installation Guide | 14-15 |

DAILY REFERENCE GUIDE



THANK YOU FOR BUYING A WHIRLPOOL PRODUCT.
In order to receive a more complete assistance, please register your appliance on: www.whirlpool.com.hk

Before using the appliance carefully read Health and Safety guide.

PRODUCT DESCRIPTION

APPLIANCE

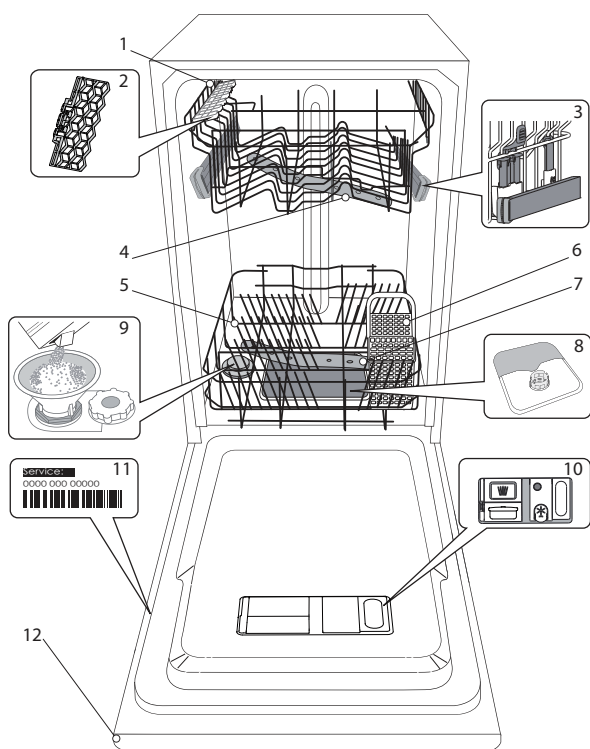

1. Upper rack
2. Foldable flaps
3. Upper rack height adjuster
4. Upper spray arm
5. Lower rack
6. Cutlery basket
7. Lower spray arm
8. Filter Assembly
9. Salt reservoir
10. Detergent and Rinse Aid dispensers
11. Rating plate
12. Control panel

CONTROL PANEL

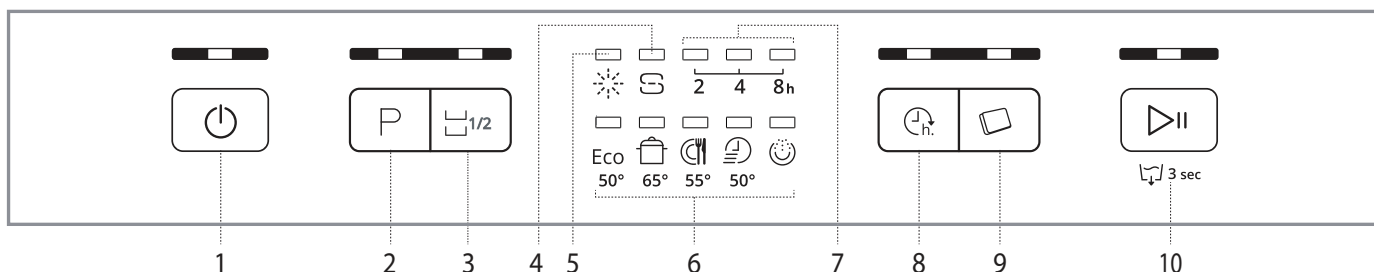

1. On-Off/Reset button with indicator light
2. Program selection button with indicator light
3. Half Load button with indicator light
4. Salt refill indicator light
5. Rinse Aid refill indicator light
6. Program indicator lights
7. Delay indicator light
8. Delay button with indicator light
9. Tablet (Tab) button with indicator light
10. Start/Pause button with indicator light / Drain out

FIRST TIME USE

SALT, RINSE AID AND DETERGENT

ADVICE REGARDING THE FIRST TIME USE

After installation, remove the stoppers from the racks and the retaining elastic elements from the upper rack.

FILLING THE SALT RESERVOIR

The use of salt prevents the formation of LIMESCALE on the dishes and on the machine's functional components.

- It is important that the salt reservoir be never empty.
- It is important to set the water hardness.

The salt reservoir is located in the lower part of the dishwasher (see *PRODUCT DESCRIPTION*) and should be filled when the **SALT REFILL indicator light**  in the control panel is lit.

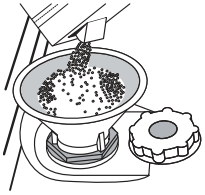

1. Remove the lower rack and unscrew the reservoir cap (anticlockwise).
2. Only the first time you do this: fill the salt reservoir with water.
3. Position the funnel (see figure) and fill the salt reservoir right up to its edge (approximately 1 kg); it is not unusual for a little water to leak out.
4. Remove the funnel and wipe any salt residue away from the opening.

Make sure the cap is screwed on tightly, so that no detergent can get into the container during the wash program (this could damage the water softener beyond repair).

Whenever you need to add salt, we recommend carrying out the procedure before the washing cycle is started.

SETTING THE WATER HARDNESS

To allow the water softener to work in a perfect way, it is essential that the water hardness setting is based on the actual water hardness in your house. This information can be obtained from your local water supplier.

The factory setting is for average (3) water hardness.

- Switch on the appliance by pressing the ON/OFF button.
- Switch off the appliance by pressing the ON/OFF button.
- Hold down button START/Pause for 5 seconds, until you hear a beep.
- Switch on the appliance by pressing the ON/OFF button.
- The program indicator light of the current set level flashes.
- Press button **P** to select the desired hardness level (see *WATER HARDNESS TABLE*).

| Level | | °dH | °fH |
|-------|-----------|---------|---------|
| 1 | Soft | 0 - 6 | 0 - 10 |
| 2 | Medium | 7 - 11 | 11 - 20 |
| 3 | Average | 12 - 17 | 21 - 30 |
| 4 | Hard | 17 - 34 | 31 - 60 |
| 5 | Very hard | 35 - 50 | 61 - 90 |

- Switch off the appliance by pressing the ON/OFF button.

Setting is complete!

As soon as this procedure is complete, run a program without loading.

Only use salt that has been specifically designed for dishwashers.

After the salt has been poured into the machine, the SALT REFILL indicator light switches off.

If the salt container is not filled, the water softener and the heating element may be damaged as a result.

FILLING THE RINSE AID DISPENSER

Rinse aid makes dish DRYING easier. The rinse aid dispenser **A** should be filled when the **RINSE AID REFILL**  indicator light in the control panel is lit.

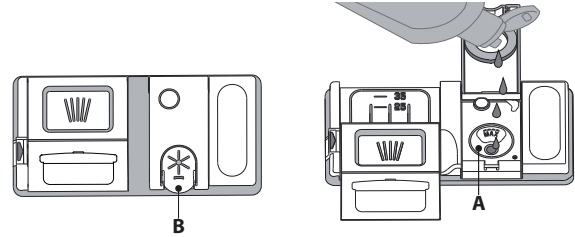

1. Open the dispenser **B** by pressing and pulling up the tab on the lid.
2. Pour in the rinse aid (max.110 ml), making sure it does not overflow from the dispenser. If this happens, clean the spill immediately with a dry cloth.
3. Press the lid down until you hear a click to close it.

NEVER pour the rinse aid directly into the appliance tub.

ADJUSTING THE DOSAGE OF RINSE AID

If you are not completely satisfied with the drying results, you can adjust the quantity of rinse aid used.

- Switch the dishwasher on using the ON/OFF button.
- Switch it off using the ON/OFF button.
- Press button START/Pause three times - a beep will be heard.
- Switch it on using the ON/OFF button.
- The program indicator light of the current set level flashes.
- Press button **P** to select the level of rinse aid quantity to be supplied.
- Switch it off using the ON/OFF button.

Setting is complete!

If the rinse aid level is set to 1 (ECO), no rinse aid will be supplied. The LOW RINSE AID indicator light will not be lit if you run out of rinse aid. A maximum of 4 levels can be set according to the dishwasher model. The factory setting is specific to the model, please follow instruction above to check this for your machine.

- If you see bluish streaks on the dishes, set a low number (2-3).
- If there are drops of water or limescale marks on the dishes, set a mid-range number (4-5).

FILLING THE DETERGENT DISPENSER

To open the detergent dispenser use the opening device A. Introduce the detergent into the dry dispenser B only. Place the amount of detergent for pre-washing directly inside the tub.

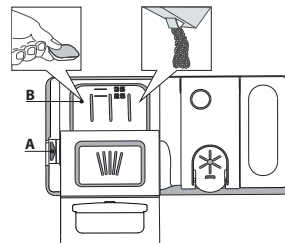

1. When measuring out the detergent refer to the mentioned earlier information to add the proper quantity. Inside the dispenser **B** there are indications to help the detergent dosing.
2. Remove detergent residues from the edges of the dispenser and close the cover until it clicks.
3. Close the lid of the detergent dispenser by pulling it up until the closing device is secured in place.

The detergent dispenser automatically opens up at the right time according to the program.

If all-in-one detergents are used, we recommend using the **TABLET** button, because it adjusts the program so that the best washing and drying results are always achieved.

PROGRAMS TABLE

| Program | Drying phase | Available options *) | Detergent container | | Default Duration of wash program (h:min)**) | Water consumption (litres/cycle) | Energy consumption (kWh/cycle) |
|-------------|--------------|----------------------|---------------------|---|---|----------------------------------|--------------------------------|
| | | | Tub | B | | | |
| 1 Eco | Eco 50° | | ✓ | ✓ | 4:00 | 11.5 | 0.83 |
| 2 Intensive | 65° | | - | ✓ | 2:30 | 15.0 | 1.50 |
| 3 Normal | 55° | | - | ✓ | 2:30 | 15.0 | 1.30 |
| 4 Rapid 30' | 50° | | - | ✓ | 0:30 | 8.5 | 0.50 |
| 5 Pre-Wash | - | | - | - | 0:10 | 4.5 | 0.01 |

ECO program data is measured under laboratory conditions according to European Standard EN 50242.

Pre-treatment of the dishes is not needed before any of the programs.

*) Not all options can be used simultaneously.

***) The duration of the program shown on the display or in the booklet is an estimate calculated on standard conditions. The actual time may vary depending on many factors such as temperature and pressure of the incoming water, room temperature, amount of detergent, quantity and type of load, load balancing, additional selected options and sensor calibration. The sensor calibration can increase program duration up to 20 min.

Standby consumption: Left-on mode consumption: 5 W - Off mode consumption: 0.5 W

PROGRAMS DESCRIPTION

Instructions on wash cycle selection.

1 ECO

Normally soiled crockery. Standard program, the most efficient in terms of its combined energy and water consumption.

2 INTENSIVE

Program recommended for heavily soiled crockery, especially suitable for pans and saucepans (not to be used for delicate items).

3 NORMAL

Mixed soil. For normally soiled dishes with dried food residues.

4 RAPID 30'

Program to be used for lightly-soiled dishes with no dried food residues. (Ideal for 2 place settings)

5 PRE-WASH

Use to refresh crockery planned to be washed later. No detergent to be used with this program.

Notes:

Please note that cycles like Rapid or Fast are most effective for lightly soiled dishes.

To reduce consumption even further, only run the dishwasher when it is full.

OPTIONS AND FUNCTIONS

OPTIONS can be selected directly by pressing the corresponding button (see CONTROL PANEL).

If an option is not compatible with the selected program see PROGRAMS TABLE, the corresponding LED flashes rapidly 3 times and beeps will sound. The option will not be enabled.



DELAY

It is possible to delay the start time of the program by 2, 4 or 8 hours:

1. After selecting the desired program and any other options, press the DELAY button. The indicator light will go on.
2. Select the desired delay time by pressing the DELAY button repeatedly. The 2 hours, 4 hours and 8 hours indicator lights will go on in succession. If the DELAY button is pressed again, the option is deselected and the indicator light goes off.
3. After the selection process, the countdown will begin if the START/PAUSE button is pressed. The selected delay-period indicator light is on and the Start/Pause button lights up (fixed light).
4. Once this time has elapsed, the DELAY indicator light goes off and the program begins.

The DELAY function cannot be set once a program has started.



TABLET (Tab)

This setting allows you to optimize the performance of the program according to the type of detergent used. Press the TABLET button (the indicator light will light up) if you use combined detergents in tablet form (rinse aid, salt and detergent in 1 dose).

If you use powder or liquid detergent, this option should be off.



1/2 HALF LOAD

If there are not many dishes to be washed, a half load cycle may be used in order to save water, electricity and detergent. Select the program and press the HALF LOAD button: the indicator light will light up. Press the HALF LOAD button to deselect this option.

Remember to halve the amount of detergent.



DRAIN OUT

To stop and cancel the active cycle, the Drain Out function can be used.

A long press of START/PAUSE button, will activate the DRAIN OUT function. The active program will be stopped and the water in the dishwasher will be drained out.

LOADING THE RACKS

UPPER RACK

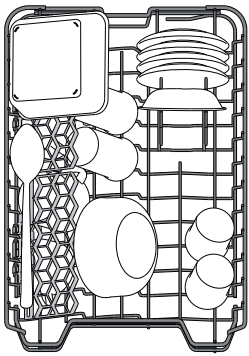

Load delicate and light dishes: glasses, cups, saucers, low salad bowls.

(loading example for the upper rack)

LOWER RACK

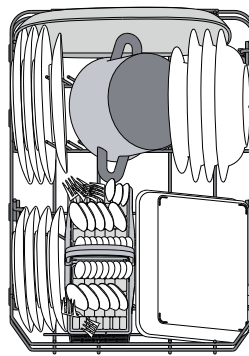

For pots, lids, plates, salad bowls, cutlery etc... Large plates and lids should ideally be placed at the sides to avoid interferences with the spray arm.

(loading example for the lower rack)

ADJUSTING THE HEIGHT OF THE UPPER RACK

The height of the upper basket can be adjusted: high position to place bulky crockery in the lower basket and low position to make the most of the tip-up compartments by creating more space upwards.

The upper rack is equipped with a **Upper Rack height adjuster** (see figure), without pressing the levers, lift it up by simply holding the rack sides, as soon as the rack is stable in its upper position. To restore to the lower position, press the levers (**A**) at the sides of the rack and move the basket downwards.

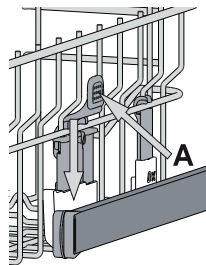

We strongly recommend that you do not adjust the height of the rack when it is loaded.

NEVER raise or lower the basket on one side only.

FOLDABLE FLAPS WITH ADJUSTABLE POSITION

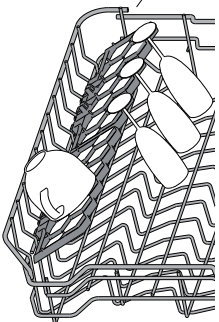

The side foldable flaps can be positioned at three different heights to optimize the arrangement of crockery inside the rack. Wine glasses can be placed safely in the foldable flaps by inserting the stem of each glass into the corresponding slots. For optimum drying results incline the foldable flaps more. To change the inclination, pull up the foldable flap, slide it slightly and position it as you wish.

CUTLERY BASKET

It is fitted with top grids for improved cutlery arrangement. It must only be positioned at the front of the lower rack.

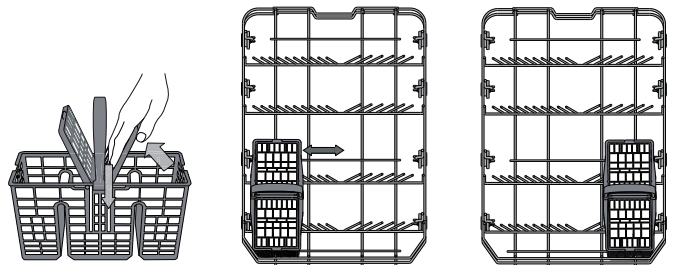

Knives and other utensils with sharp edges must be placed in the cutlery basket with the points facing downwards or they must be positioned horizontally in the tip-up compartments on the upper rack.

DAILY USE

1. CHECK WATER CONNECTION

Check that the dishwasher is connected to the water supply and that the top is open.

2. SWITCH ON THE DISHWASHER

Press the ON/OFF button.

3. LOAD THE RACKS

(see LOADING THE RACKS)

4. FILLING THE DETERGENT DISPENSER

(see PROGRAMS TABLE).

5. CHOOSE THE PROGRAM AND CUSTOMISE THE CYCLE

Select the most appropriate program in accordance with the type of crockery and its soiling level (see PROGRAMS DESCRIPTION) by pressing the **P** button.

Select the desired options (see OPTIONS AND FUNCTIONS).

6. START

Start the wash cycle by pressing the START/PAUSE button. When the program starts you hear a beep.

7. END OF WASH CYCLE

The end of the wash cycle is indicated by beeps and by the flashing of the wash cycle indicator on the panel. Open the door and switch off the appliance by pressing the ON/OFF button. Wait for a few minutes before removing the crockery - to avoid burns. Unload the racks, beginning with the lower one.

The machine will switch off automatically during certain extended periods of inactivity, in order to minimise electricity consumption. If the crockery is only lightly soiled or if it has been rinsed with water before being placed in the dishwasher, reduce the amount of detergent used accordingly.

MODIFYING A RUNNING PROGRAM

If a wrong program was selected, it is possible to change it, provided that it has only just begun: press and hold the ON/OFF button, the machine will switch off. Switch the machine back on using the ON/OFF button and select the new wash cycle and any desired options; start the cycle by pressing the START/PAUSE button.

ADDING EXTRA CROCKERY

Without switching off the machine, open the door (**be ware of HOT steam!**) and place the crockery inside the dishwasher. Close the door and press the START/PAUSE button the cycle will begin from the point at which it was interrupted.

ACCIDENTAL INTERRUPTIONS

If the door is opened during the wash cycle, or if there is a power cut, the cycle stops. Once the door has been closed or the electricity supply is restored, to start again the cycle from where it was interrupted, press the START/PAUSE button.

ADVICE AND TIPS

TIPS

Before loading the baskets, remove all food residues from the crockery and empty the glasses. **You do not need to rinse beforehand under running water.** Arrange the crockery so that it is held in place firmly and does not tip over; and arrange the containers with the openings facing down-wards and the concave/convex parts placed obliquely, thus allowing the water to reach every surface and flow freely.

Warning: lids, handles, trays and frying pans do not prevent the sprayer arms from rotating. Place any small items in the cutlery basket. Very soiled dishes and pans should be placed in the lower basket because in this sector the water sprays are stronger and allow a higher washing performance. After loading the appliance, make sure that the sprayer arms can rotate freely.

HYGIENE

To avoid odour and sediment which can be accumulated in the dishwasher please run a high temperature program at least one a month. Use a tea spoon of detergent and run it without the loading to clean your appliance.

UNSUITABLE CROCKERY

- Wooden crockery and cutlery.
- Delicate decorated glasses, artistic handicraft and antique crockery. Their decorations are not resistant.
- Parts in synthetic material which do not withstand high temperatures.
- Copper and tin crockery.
- Crockery soiled with ash, wax, lubricating grease or ink.

The colours of glass decorations and aluminium/silver pieces can change and fade during the washing process. Some types of glass (e.g. crystal objects) can become opaque after a number of wash cycles too.

DAMAGE TO GLASS AND CROCKERY

- Only use glasses and porcelain guaranteed by the manufacturer as dishwasher safe.
- Use a delicate detergent suitable for crockery.
- Collect glasses and cutlery from the dishwasher as soon as the wash cycle is over.

CARE AND MAINTENANCE

CLEANING THE FILTER ASSEMBLY

Regularly clean the filter assembly so that the filters do not clog and that the waste water flows away correctly.

The filter assembly consists of three filters which remove food residues from the washing water and then recirculate the water: to obtain the best washing results, you need to keep them clean.

The dishwasher must not be used without filters or if the filter is loose.

After several washes, check the filter assembly and if necessary clean it thoroughly under running water, using a non-metallic brush and following the instructions below:

1. Turn the cylindrical filter **A** in an anti-clockwise direction and pull it out (Fig 1).
2. Remove the cup filter **B** by exerting a slight pressure on the side flaps (Fig 2).
3. Slide out the stainless-steel plate filter **C** (Fig 3).
4. Inspect the trap and remove any food residues. **NEVER REMOVE** the wash-cycle pump protection (black detail) (Fig 4).

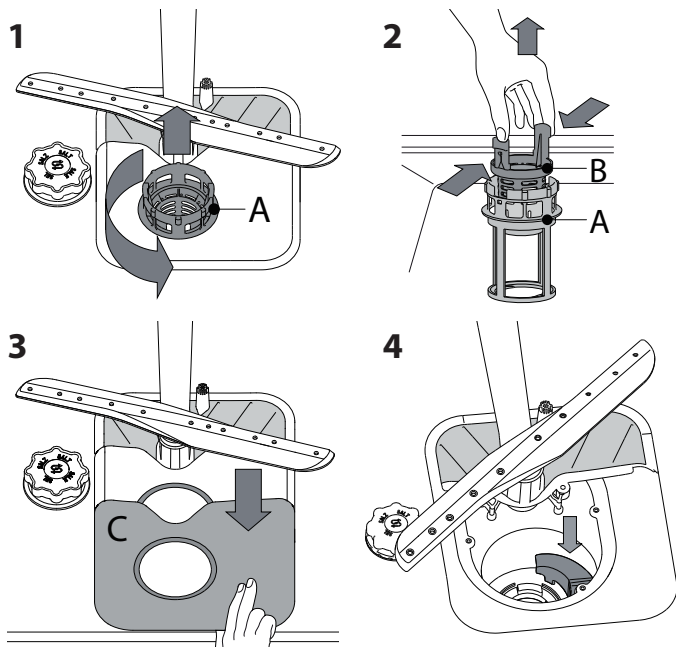

After cleaning the filters, re-place the filter assembly and fix it in position correctly; this is essential for maintaining the efficient operation of the dishwasher.

CLEANING THE SPRAY ARMS

On occasions, food residue may become encrusted onto the spray arms and block the holes used to spray the water. It is therefore recommended that you check the arms from time to time and clean them with a small non-metallic brush.

To remove the upper spray arm, turn the plastic locking ring in an anti-clockwise direction. The upper spray arm should be replaced so that the side with the greater number of holes is facing upwards.

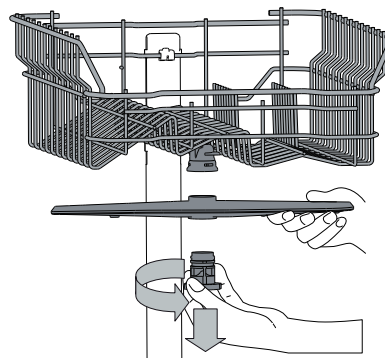

The lower spray arm may be removed by pulling it upwards.

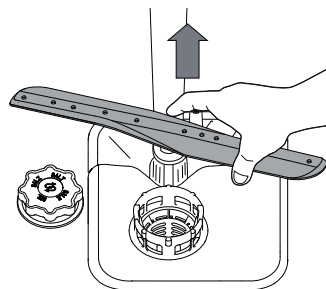

CLEANING THE WATER INLET HOSE

If the water hoses are new or have not been used for an extended period of time, let the water run to make sure it is clear and free of impurities before performing the necessary connections. If this precaution is not taken, the water inlet could become blocked and damage the dishwasher.

TROUBLESHOOTING

Your dishwasher may not work properly.

Before contacting the Service Centre check if the problem can be solved by going through the following list.

| PROBLEMS | POSSIBLE CAUSES | SOLUTIONS |
|--|--|--|
| The dishwasher won't start or does not respond to com-mands. | The appliance has not been plugged in properly. | Insert the plug into the socket. |
| | Power outage. | The dishwasher starts automatically when the power returns. |
| | The dishwasher door is not closed. | Vigorously push the door until you hear the "click". |
| | It does not respond to commands. | Switch off the appliance by pressing the ON/OFF button, switch it back on after approximately one minute and reset the program. |
| The dishwasher won't drain. | The wash cycle has not finished yet. | Wait until the wash cycle finishes. |
| | The drain hose is bent. | Check that the drain hose is not bent (see INSTALATION INSTRUCTION). |
| | The sink drain pipe is blocked. | Clean the sink drain pipe. |
| | The filter is clogged up with food residues. | Clean the filter (see CLEANING THE FILTER ASSEMBLY). |
| The dishwasher makes excessive noise. | The dishes are rattling against each. | Position the crockery correctly (see LOADING THE RACKS). |
| | An excessive amount of foam has been produced. | The detergent has not been measured out correctly or it is not suitable for use in dishwashers (see FILLING THE DETERGENT DISPENSER). Reset dishwasher by pressing the DRAIN button (see OPTIONS AND FUNCTIONS) and run new program without detergent. |
| The dishes are not clean. | The crockery has not been arranged properly. | Arrange the crockery correctly (see LOADING THE RACKS). |
| | The spray arms cannot rotate freely, being hindered by the dishes. | Arrange the crockery correctly (see LOADING THE RACKS). |
| | The wash cycle is too gentle. | Select an appropriate wash cycle (see PROGRAMS TABLE). |
| | An excessive amount of foam has been produced. | The detergent has not been measured out correctly or it is not suitable for use in dishwashers (see FILLING THE DETERGENT DISPENSER). |
| | The cap on the rinse aid compartment has not been shut correctly. | Make sure the cap of the rinse aid dispenser is closed. |
| | The filter is soiled or clogged. | Clean the filter assembly (see CARE AND MAINTENANCE). |
| | There is no salt. | Fill the salt reservoir (see FILLING THE SALT RESERVOIR). |

MAINTENANCE AND TROUBLESHOOTING GUIDE

For more information, see the *Use and Care Guide*
The *Use and Care Guide* can be obtained by:

- After-Sales Service; phone number see in warranty booklet.
- Download from website: www.whirlpool.com.hk

CONTACTING AFTER-SALES SERVICE

When you contact the After-Sales Service, you must provide the codes shown on the rating plate attached to the left or right side inside the door of the dishwasher. The phone number is listed in the warranty booklet or on the website: www.whirlpool.com.hk

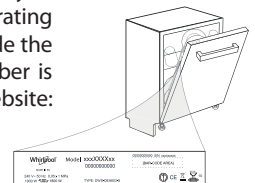

HEALTH & SAFETY GUIDE

IMPORTANT TO BE READ AND OBSERVED

Before using the appliance, read these safety instructions. Keep them nearby for future reference. These instructions and the appliance itself provide important safety warnings, to be observed at all times. The manufacturer declines any liability for failure to observe these safety instructions, for inappropriate use of the appliance or incorrect setting of controls.

⚠ Very young children (0-3 years) should be kept away from the appliance. Young children (3-8 years) should be kept away from the appliance unless continuously supervised. Children from 8 years old and above and persons with reduced physical, sensory or mental capabilities or lack of experience and knowledge can use this appliance only if they are supervised or have been given instructions on safe use and understand the hazards involved. Children must not play with the appliance. Cleaning and user maintenance must not be carried out by children without supervision.

PERMITTED USE

⚠ CAUTION: the appliance is not intended to be operated by means of an external switching device, such as a timer, or separate remote controlled system.

⚠ This appliance is intended to be used in household and similar applications such as: staff kitchen areas in shops, offices and other working environments; farm houses; by clients in hotels, motels, bed & breakfast and other residential environments.

⚠ The maximum number of place settings is shown in the product sheet.

⚠ The door should not be left in the open position - risk of tripping. The open appliance door can only support the weight of the loaded rack when pulled out. Do not rest objects on the door or sit or stand on it.

⚠ WARNING: Dishwasher detergents are strongly alkaline. They can be extremely dangerous if swallowed. Avoid contact with the skin and eyes and keep children away from the dishwasher when the door is open. Check that the detergent receptacle is empty after completion of the wash cycle.

⚠ WARNING: Knives and other utensils with sharp points must be loaded in the basket with their points down or placed in a horizontal position - risk of cuts.

⚠ This appliance is not for professional use. Do not use the appliance outdoors. Do not store explosive or flammable substances (e.g. gasoline or aerosol cans) inside or near the appliance - risk of fire. The appliance must be used only to wash domestic dishes in accordance with the instructions in this manual. The water in the appliance is not potable. Use only detergent and rinse additives designed for an automatic dishwasher. When adding a water softener (salt), run one cycle

immediately with the machine empty, to avoid corrosion damage to internal parts. Store the detergent, rinse aid and salt out of reach of children. Shut off the water supply and unplug or disconnect the power before servicing and maintenance. Disconnect the appliance in the event of any malfunction.

INSTALLATION

⚠ The appliance must be handled and installed by two or more persons - risk of injury. Use protective gloves to unpack and install - risk of cuts. Connect the dishwasher to the water mains using only new hose sets. The old hose sets should not be reused. All hoses must be securely clamped to prevent them coming loose during operation. All local waterboard regulations must be complied with. Water supply pressure 0.05 - 1.0 MPa. The appliance must be placed against the wall or built into furniture to limit the access to its rearside. For dishwashers having ventilation openings in the base, the openings must not be obstructed by a carpet.

⚠ Installation, including water supply (if any) and electrical connections, and repairs must be carried out by a qualified technician. Do not repair or replace any part of the appliance unless specifically stated in the user manual. Keep children away from the installation site. After unpacking the appliance, make sure that it has not been damaged during transport. In the event of problems, contact the dealer or your nearest After-sales Service. Once installed, packaging waste (plastic, styrofoam parts etc.) must be stored out of reach of children - risk of suffocation. The appliance must be disconnected from the power supply before any installation operation - risk of electrical shock. During installation, make sure the appliance does not damage the power cable - risk of fire or electrical shock. Only activate the appliance when the installation has been completed.

If installing the dishwasher at the end of a row of units making the side panel accessible, the hinge area must be covered to avoid risk of injury. The inlet water temperature depends on the dishwasher model. If the installed inlet hose is marked "25° C Max", the maximum allowed water temperature is 25°C. For all other models the maximum allowed water temperature is 60°C.

Do not cut hoses and, in the case of appliances fitted with a waterstop system, do not immerse the plastic casing containing the inlet hose in water. If hoses are not long enough, contact your local dealer. Make sure the inlet and drain hoses are kink-free and are not crushed. Before using the appliance for the first time, check the water inlet and drain hose for leaks. Make sure that the feet are stable and resting on the floor, adjusting them as required, and check that the dishwasher is perfectly levelled using a spirit level.

ELECTRICAL WARNINGS

The rating plate is on the edge of the dishwasher door (visible when the door is open).

 It must be possible to disconnect the appliance from the power supply by unplugging it if plug is accessible, or by a multi-pole switch installed upstream of the socket and the appliance must be earthed, in conformity with national electrical safety standards.

 Do not use extension leads, multiple sockets or adapters. The electrical components must not be accessible to the user after installation. Do not use the appliance when you are wet or barefoot. Do not operate this appliance if it has a damaged power cable or plug, if it is not working properly, or if it has been damaged or dropped.

 If the supply cord is damaged, it must be replaced with an identical one by the manufacturer, its service agent or similarly qualified persons in order to avoid a hazard - risk of electrical shock.

If the fitted plug is not suitable for your socket outlet, contact a qualified technician. Do not pull the power supply cable. Do not immerse the mains cord or plug in water. Keep the cord away from hot surfaces.

CLEANING AND MAINTENANCE

 **WARNING: Ensure that the appliance is switched off and disconnected from the power supply before performing any maintenance operation - risk of electrical shock. Never use steam cleaning equipment.**

DISPOSAL OF PACKAGING MATERIALS

The packaging material is 100% recyclable and is marked with the recycle symbol . The various parts of the packaging must therefore be disposed of responsibly and in full compliance with local authority regulations governing waste disposal.

DISPOSAL OF HOUSEHOLD APPLIANCES

This appliance is manufactured with recyclable or reusable materials. Dispose of it in accordance with local waste disposal regulations. For further information on the treatment, recovery and recycling of household electrical appliances, contact your local authority, the collection service for household waste or the store where you purchased the appliance. This appliance is marked in compliance with European Directive 2012/19/EU, Waste Electrical and Electronic Equipment (WEEE). By ensuring this product is disposed of correctly, you will help prevent negative consequences for the environment and human health.

The  symbol on the product or on the accompanying documentation indicates that it should not be treated as domestic waste but must be taken to an appropriate collection center for the recycling of electrical and electronic equipment.

ENERGY SAVING TIPS

ECO: it is the standard cleaning cycle, it is suitable to clean normally soiled tableware and that it is the most efficient programme in terms of its combined energy and water consumption for that type of tableware.

INSTALLATION GUIDE

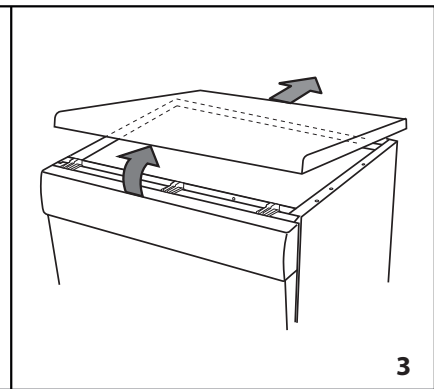
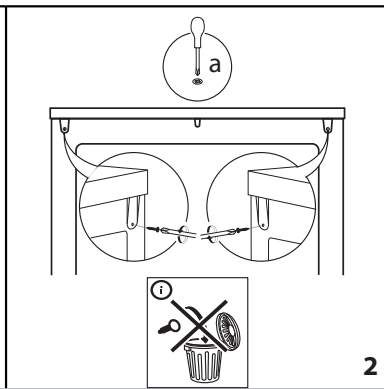
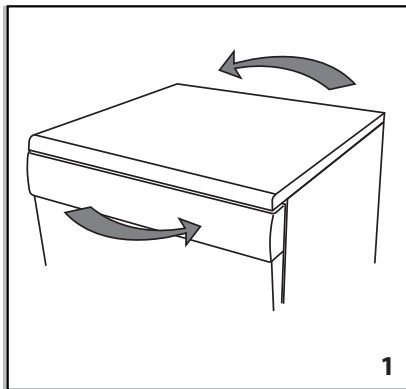
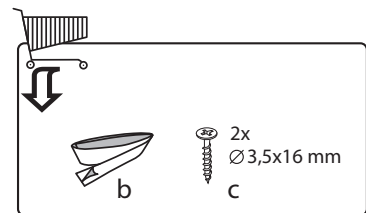
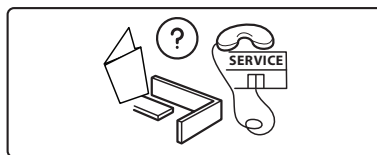
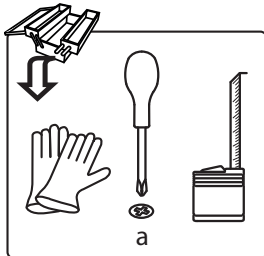
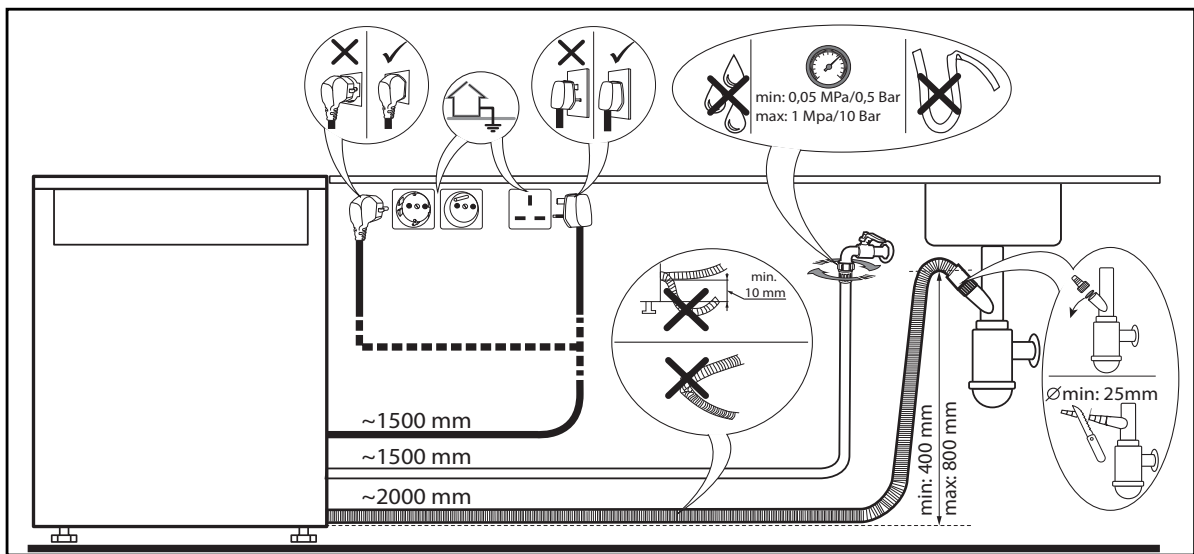
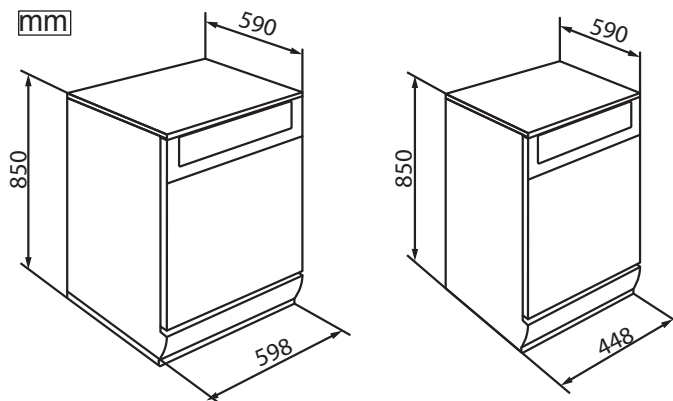

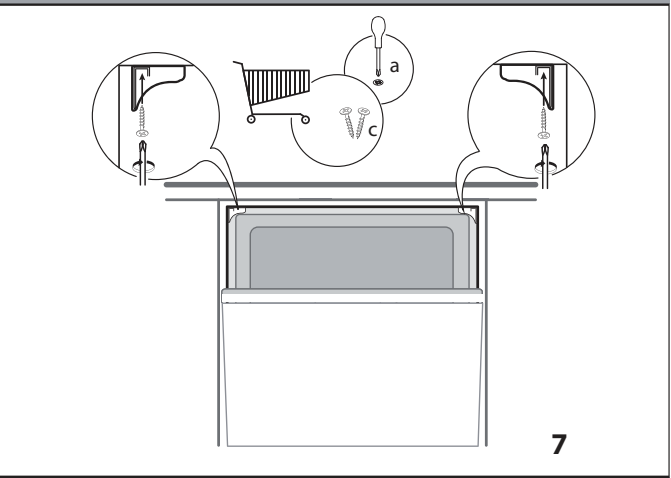
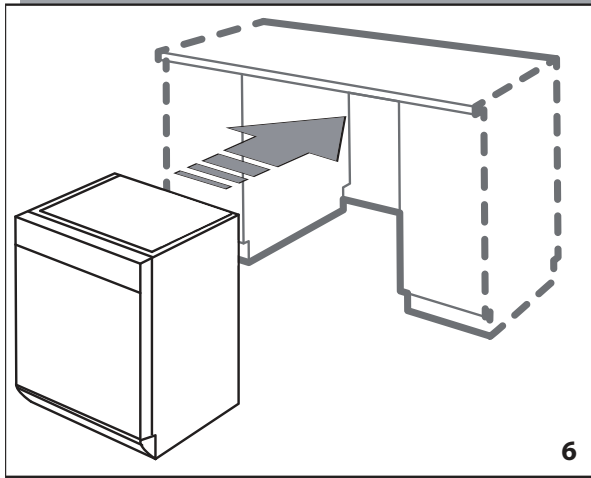
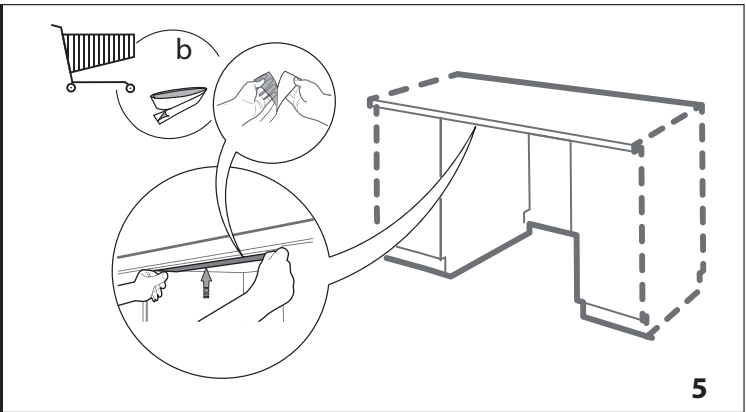
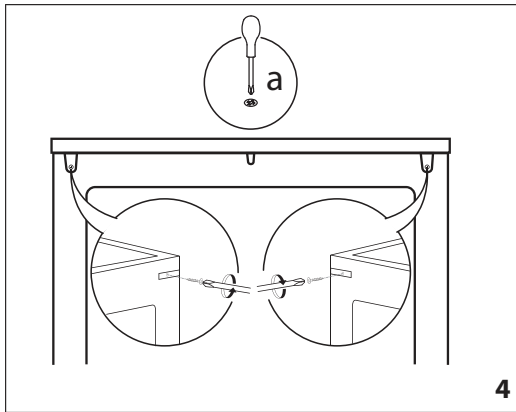

使用說明書



感謝您購買惠而浦產品
為了獲得更完善的服務，
請於www.whirlpool.com.hk註冊您的產品

索引

| | |
|--------------------------------|--------------|
| 使用說明書 | 16 |
| 產品介紹 | 17 |
| 產品結構 | 17 |
| 控制面板 | 17 |
| 首次使用 (洗碗碟機專用軟水劑、吹乾劑、清潔劑) | 18 |
| 程序表 | 19 |
| 程序 | 19 |
| 選項及功能 | 20 |
| 裝置層架 | 21 |
| 日常使用 | 22 |
| 建議及提示 | 22 |
| 保養及維修 | 23 |
| 清潔過濾器組件 | 23 |
| 清潔噴灑臂 | 23 |
| 清潔進水口軟管 | 23 |
| 故障排除 | 24 |
| 健康及安全指引 | 25-26 |
| 安裝指引 | 27-28 |

使用說明書



感謝您購買惠而浦產品
為了獲得更完善的服務，
請於www.whirlpool.com.hk註冊您的產品

使用洗碗碟機前請先細閱產品安全指引

產品介紹

產品結構

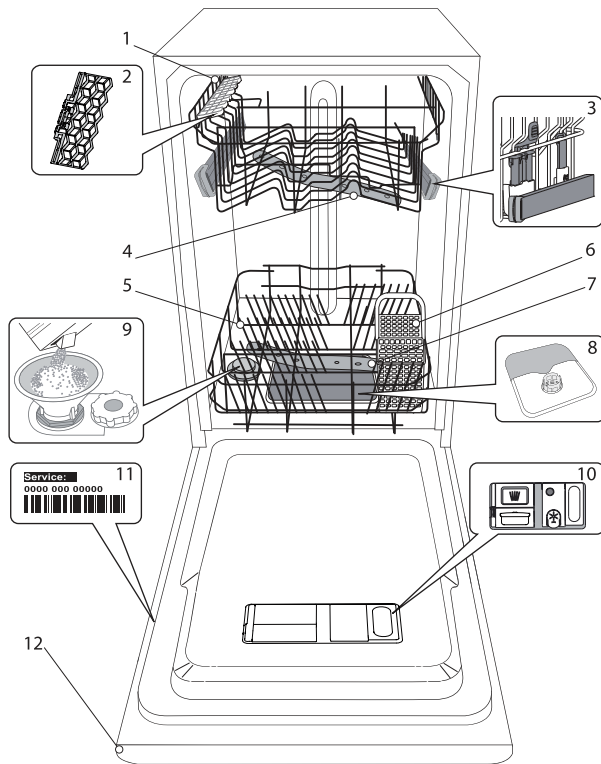

1. 上層餐具層架
2. 可摺疊盛載架
3. 上層餐具層架高度調節器
4. 上層噴灑臂
5. 下層餐具層架
6. 餐具籃
7. 下層噴灑臂
8. 過濾器組件
9. 洗碗碟機專用軟水劑儲存器
10. 洗碗碟機專用清潔劑及吹乾劑儲存器
11. 銘牌
12. 控制面板

控制面板

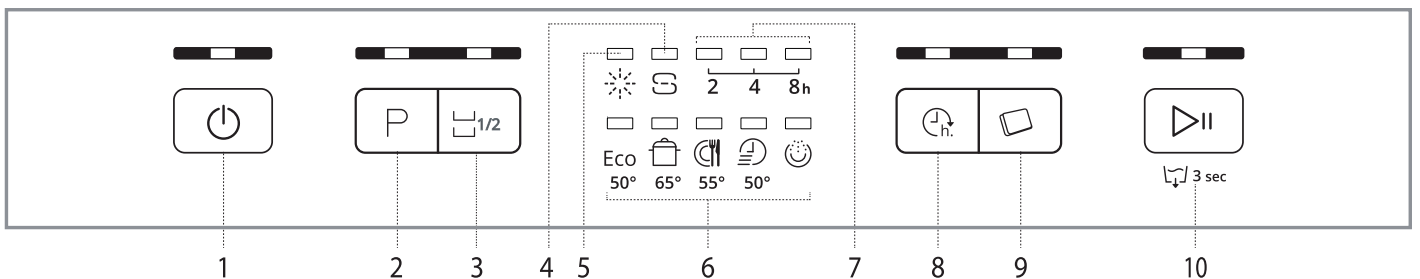

1. 電源「開/關/重設」鍵及指示燈
2. 「程序」鍵及指示燈
3. 「半量清洗」鍵及指示燈
4. 「洗碗碟機專用軟水劑注入提示」指示燈
5. 「洗碗碟機專用吹乾劑注入提示」指示燈
6. 「程序」指示燈
7. 「預校開機時間」指示燈
8. 「預校開機時間」鍵及指示燈
9. 「洗碗碟機專用清潔片」鍵及指示燈
10. 「啟動/暫停」鍵及指示燈 / 排水鍵

首次使用

洗碗碟機專用軟水劑、吹乾劑、清潔劑

首次使用的建議

安裝機件完畢後，首先將層架上的栓塞及上層層架的彈性緩衝物件移除。

注入專用軟水劑

使用洗碗碟機專用軟水劑可防止餐具及機件上形成水垢。

- 注意：專用軟水劑儲存器不可空著。
- 注意：必須設定水的硬度。

專用軟水劑儲存器位於洗碗碟機內底部(請參閱「程序」篇章)。必須於控制面板上的「專用軟水劑注入提示」指示燈  亮起時將儲存器注滿。

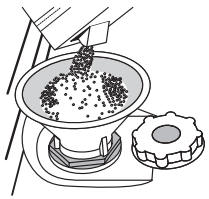

1. 拉出下層層架，扭開儲存器的蓋子(逆時針方向)。
2. 將水填滿儲存器(只限第一次使用時)。
3. 放置漏斗(見左圖)並倒入專用軟水劑(約1公斤)；若過程中有少量水洩漏，實屬正常。
3. 移除漏斗，並擦去開口處的專用軟水劑殘留物。

確認儲存器的蓋子已擰緊，以確保在清洗過程中沒有清潔劑進入儲存器內(這可能會損壞軟水劑而無法修復)。

每當您需要添加專用軟水劑時，我們建議在清洗程序開始前進行添加。

設定水的硬度

為了使軟水劑能完善地運作，我們必須確保水的硬度設置是依照家居水喉水的硬度而定。有關信息可從本地供水商獲得。一般的出廠設置為平均(3)水硬度。

- 按下電源「開/關/重設」鍵，以啟動洗碗碟機。
- 按下電源「開/關/重設」鍵，以關閉洗碗碟機。
- 按住「啟動/暫停」鍵5秒，直至聽到「咁」一聲。
- 按下電源「開/關/重設」鍵，以啟動洗碗碟機。
- 當前水硬度的所屬級別指示燈會閃爍。
- 按下「程序」鍵 P 以選擇所需的水硬度水平(請參閱「軟水/硬水程度表」)。

| 軟水/硬水程度表 | | | |
|----------|----|---------|---------|
| 程度 | | °dH | °fH |
| 1 | 軟 | 0 - 6 | 0 - 10 |
| 2 | 中度 | 7 - 11 | 11 - 20 |
| 3 | 平均 | 12 - 17 | 21 - 30 |
| 4 | 硬 | 17 - 34 | 31 - 60 |
| 5 | 最硬 | 35 - 50 | 61 - 90 |

- 按下電源「開/關/重設」鍵，以關閉洗碗碟機。
- 設置完成！
完成上述步驟後，立即於不加载碗碟的情況下運行一次程序。
只能使用專為洗碗機設計的專用軟水劑。
倒入專用軟水劑後，「洗碗碟機專用軟水劑注入提示」指示燈將熄滅。
若沒有加入專用軟水劑，軟水劑和加熱配件可能因此而損壞。

注入吹乾劑

吹乾劑可使碗碟更容易乾透，必須於控制面板上的「洗碗碟機吹乾劑注入提示」指示燈亮起  時將吹乾劑注入吹乾劑盒A內。

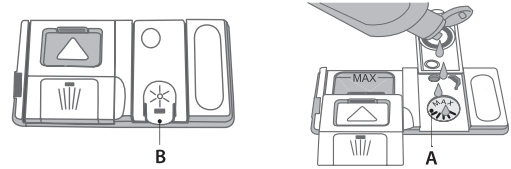

1. 按下及拉起吹乾劑盒蓋子(B)。
2. 小心地倒入吹乾劑(最多110ml)直至填滿盒子，避免液體溢出。若吹乾劑滲漏，請立即用乾布抹乾。
3. 按下蓋子，直至聽到「喀嗒」一聲，以確認關閉蓋子。

切勿將吹乾劑直接倒入洗碗碟機內桶。

調整吹乾劑的劑量

若乾透程度未如理想，可以調整吹乾劑的使用量以加強效果。

- 按下電源「開/關/重設」鍵，以啟動洗碗碟機。
 - 按下電源「開/關/重設」鍵，以關閉洗碗碟機。
 - 按住「啟動/暫停」鍵5秒，直至聽到「咁」一聲。
 - 按下電源「開/關/重設」鍵，以啟動洗碗碟機。
 - 當前吹乾劑的所屬水平指示燈會閃爍。
 - 按下「程序」鍵 P 以選擇所需吹乾劑的劑量級別。
 - 按下電源「開/關/重設」鍵，以關閉洗碗碟機。
- 設置完成！

若吹乾劑級別設置為1(ECO)，系統將不會使用吹乾劑，若吹乾劑已用畢，「洗碗碟機專用吹乾劑注入提示」指示燈將不會亮起。根據洗碗碟機型號，最多可設置4個級別。此型號設有特定的原廠設定，請根據上述指引檢查洗碗碟機的設定。

- 如果你看到餐具上有藍色條紋，請設置較小的數字(2-3)。
- 如果餐具上有水滴或水垢，請設置一個較大的數字(4-5)。

注入清潔劑

按一下(A)鍵打開清潔劑盒。請確保清潔劑只放入乾爽的裝置B內，然後把用於預洗的清潔劑份量直接倒入內桶。

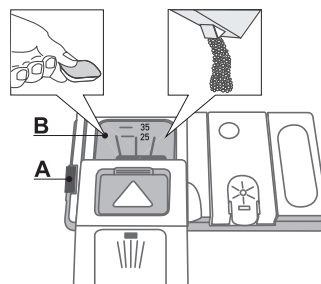

1. 測量清潔劑時，請參閱「程序表」以添加適當的份量。
裝置B內設有份量指標供參考。
2. 移除清潔劑盒框邊多餘的清潔劑殘留物。關閉蓋子直至聽到「喀嗒」一聲。
3. 拉起清潔劑盒的蓋子，直至關閉裝置到位，清潔劑盒的蓋子關上。

根據程序，清潔劑盒會在合適的時間自動打開。

如果使用多合一清潔片，我們建議使用「洗碗碟機專用清潔片」按鈕，因為程序會調整至獲得最佳的洗滌和烘乾的效果。

程序表

| 程序 | 乾燥 烘乾 | 可用選項* | 清潔劑 儲存位置 | | 預設清洗 程序時間 (小時:分鐘)** | 耗水量 (公升/循環) | 能源消耗 (千瓦小時/循環) |
|-----------------------|----------|-------|-------------|-----|---------------------------|----------------|-------------------|
| | | | 內桶 | 裝置B | | | |
| 1. 省電洗 Eco 50° | ✓ | | ✓ | ✓ | 4:00 | 11.5 | 0.83 |
| 2. 密集洗 65° | ✓ | | - | ✓ | 2:30 | 15.0 | 1.50 |
| 3. 日日洗 55° | ✓ | | - | ✓ | 2:30 | 15.0 | 1.30 |
| 4. 30分鐘快洗 50° | - | | - | ✓ | 0:30 | 8.5 | 0.50 |
| 5. 預洗(冷水) - | - | | - | - | 0:10 | 4.5 | 0.01 |

省電洗程序的數據是實驗室根據歐洲標準EN 50242的條件下而測量。

所有清洗程序開啟前，碗碟皆不需預先進行特別處理。

*) 並非所有選項都可以同時使用。

***) 顯示器或本說明書中顯示的清洗程序時間是根據標準條件計算的估計值。實際時間可能因許多因素而異，例如進水的溫度和壓力、室溫、清潔劑的數量、負載量和類型、負載平衡、使用的選項和傳感器的校準。傳感器校準可將清洗程序時間延長至20分鐘。待機功率消耗：備用模式功率消耗：5 W - 關閉模式功率消耗：0.5 W

程序

清洗程序的詳細說明。

1. 省電洗

適用於一般骯髒的餐具，此為標準清洗程序，在能源消耗和耗水量方面，綜合消耗的結果來看，效率為最高。

2. 密集洗

建議用於嚴重骯髒的餐具，特別適用於平底鍋和燉鍋(不適用於精緻易碎的物品)。

3. 日日洗

適用於一般骯髒的餐具，可用作一般日常清洗程序，程序可在更短的時間內達至最佳的清潔效能。

4. 30分鐘快洗

程序用於輕度骯髒並其表面沒有乾透的食物殘渣的餐具(用作清洗2套餐具表現最理想)。

5. 預洗(冷水)

適用於待洗的餐具。此程序不需使用任何清潔劑。

備註：

「快速」程序是清洗輕度骯髒的餐具最佳選擇。

只於洗碗機裝滿時才運行清洗程序，以進一步減少能源消耗。

選項及功能

透過按下相應按鈕，可直接揀選所需選項(請參閱「控制面板」篇章)。

如果某個選項與所選程序不兼容(請參閱「程序表」篇章)，相應的LED指示燈將快速閃爍3次，並發出「呖」聲。屆時該選項將不會被啟用。



「預校開機時間」

可選擇延遲2小時、4小時或8小時才啟動清洗程序。

1. 選擇程序和所需選項。按下「預校開機時間」按鈕，相關指示燈將會亮起。
2. 重複按下「預校開機時間」按鈕以選取所需延遲時間，「2小時」、「4小時」、「8小時」的指示燈將會相應地亮起。若此時再次按下「預校開機時間」按鈕，延遲選項將被取消，而相關指示燈亦會熄滅。
3. 選取完成後，按下「啟動/暫停」鍵，計時器開始倒數。所選延遲時間的指示燈將會亮起，而「啟動/暫停」鍵的指示燈亦會發出固定亮光。
4. 時間結束後，指示燈熄滅，清洗程序便會自動開始。

一旦清洗程序啟動，將無法再設置「預校開機時間」選項。



「洗碗碟機專用清潔片」

此設置允許您根據所用清潔劑的類型來優化程序的表現。按下「洗碗碟機專用清潔片」按鈕，如果您使用片劑形式的多合一洗碗碟機專用清潔片(軟水劑、吹乾劑和清潔劑)，相應的符號將亮起。

如果使用洗碗碟機專用清潔粉末或清潔液，則應關閉此選項。



「半量清洗」

如所需清洗的餐具數量不多，可以使用半量清洗設定，以節省水、電和清潔劑。選擇程序並按下「半量清洗」按鈕：按鈕上方的指示燈將會亮起。

再次按下「半量清洗」鍵可取消選項。
請將清潔劑的量減半。



「排水」

清洗程序運行中的時候，若需要中途停止/取消清洗程序，可以使用「排水」功能。

長按「啟動/暫停」鍵，啟動「排水」功能，清洗程序將被終止，洗碗碟機內的水亦會被排走。

裝置層架

上層層架

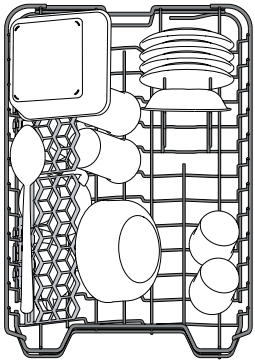

(上層層架的加載示範)

擺放精緻和輕巧的器具：
玻璃、杯子、碟子、沙拉碗。

下層層架

用於煲、蓋、碟子、沙拉碗、餐具等。
大型碟子和蓋子應放在兩側，以避免阻擋噴灑臂。

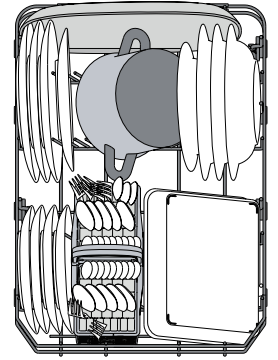

(下層層架的加載示範)

調整上層層架高度

上層餐具層架的高度可以調節：調高後，以便在下層層架和低位置放置較大型的器具；調低後，可為上層騰出更多空間。

上層層架備配有**高度調節器**(見圖)，不需按下手柄，只需握住層架兩側即可將其抬起並固定位置。要恢復到較低位置，請按下上層層架兩側的桿A並向下移動籃子。

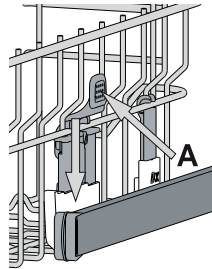

我們強烈建議於層架載滿時不要調節層架高度。
切勿僅升高/降低單側層架。

餐具籃

餐具籃表面佈滿方格供放置不同餐具。
餐具籃必須放於下層層架的前方。

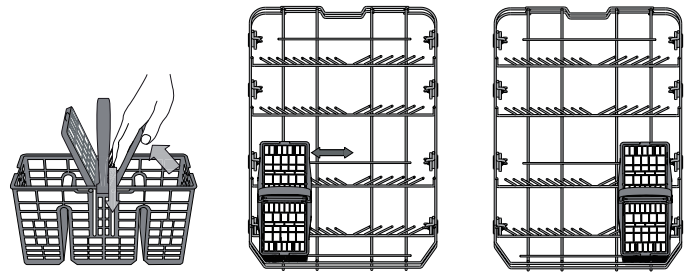

餐刀和其它具有鋒利邊緣的餐具必須刀尖朝下放置於餐具籃內或水平放置於上層層架的固定組件上。

可調節位置的可摺疊盛載架

側面可摺疊的盛載架可以設定在三個不同的高度，以優化機架內的餐具放置。將酒杯腳卡在可摺疊的盛載架上，令酒杯可以安放於洗碗碟機內。

摺疊盛載架，增加其傾斜度，可達至最佳烘乾效果。

如欲改變盛載架的傾斜度，請拉起可摺疊翻蓋，輕輕滑動並根據需要定位。

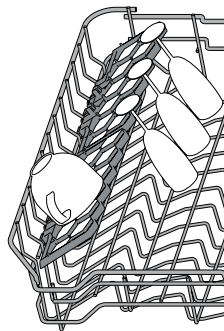

日常使用

1. 檢查水喉連接

檢查洗碗碟機是否連接到供水系統並且頂部是否打開。

2. 開啟洗碗碟機

按下電源「開/關 / 重設」鍵。

3. 負載層架

(請參看「裝置層架」篇章)。

4. 注入清潔劑盒

(請參看「程序表」)。

5. 選擇程序並自訂選項

按下「程序」(P)按鈕，根據餐具類型及其污染程度選擇最合適的程序 (參見「程序」說明)。

選擇所需的選項 (請參閱「選項和功能」篇章)。

6. 開始

按「啟動/暫停」鍵開始清洗程序。程序啟動時，您會聽到「呖」聲。

7. 結束清洗程序

清洗程序結束時會發出連續的「呖」聲，顯示屏會顯示「END」。打開門，按電源「開/關/重設」鍵，以關閉設備。數分鐘後才取出餐具 - 以免燙傷。從下層層架開始卸載。

若洗碗碟機靜止一段時間，設備將會自動關閉，以減少電力消耗。如果餐具只是輕微弄髒，或者在放入洗碗碟機之前已經用水沖洗過，那麼可適當地減少清潔劑的使用量。

修改運行中的程序

如果選擇了錯誤的程序，可於程序剛啟動時作出修改：按住電源「開/關 / 重設」鍵關閉機器。使用電源「開/關 / 重設」鍵重新啟動機器，再次選擇新的洗滌程序和所需的選項。按「啟動/暫停」鍵開始程序。

添加額外餐具

不需關閉機器，打開門 (注意：小心熱蒸氣!) 將餐具放入洗碗碟機內，關門並按「啟動/暫停」鍵，程序將從中斷點開始重啟。

運行中的程序中斷

如果在清洗程序期間打開門或者斷電，清洗程序會暫停。當機門關閉或電源恢復後，按「啟動/暫停」鍵，程序將再次從中斷點開始重啟。

建議及提示

小貼士

在裝入餐具層架前，先清空玻璃餐具內所有物件，並從餐具中去除所有的食物殘渣。不需要預先沖洗餐具。

適當放置餐具使其牢牢固定於層架上，不會翻倒。將容器開口朝向下放置，凹/凸部分傾斜放置，從而令水能觸及每個表面並自由流動。

警告：蓋子、手柄、托盤和煎鍋不會阻止噴灑臂旋轉。

將所有小物品放在餐具籃中。

非常骯髒的餐具和平底鍋應放置於下層層架裡，因為在這個區域噴水更強，洗滌效能更高。

完成放置餐具及層架後，必須確保噴灑臂可以自由旋轉。

衛生

為避免氣味和沈澱物積聚於洗碗碟機內，請至少每月運行一次高溫程序。使用茶匙份量的清潔劑，並在沒有裝載的情況下運行高溫程序來清潔您的設備。

不合適的餐具

- 木製餐具。
- 精緻裝飾的玻璃，藝術工藝品和古董。
- 合成材料中不能承受高溫的物件。
- 銅和錫餐具。
- 被灰、蠟、潤滑脂或油墨弄髒的餐具。

在清洗過程中，玻璃和鋁/銀碎片裝飾的顏色會發生變化和褪色。某些類型的玻璃(例如水晶)也可能在多次清洗程序後變得不透明。

對玻璃餐具和其它餐具的損害

- 只能使用製造商保證的適用於洗碗碟機玻璃和餐具。
- 使用適合精緻餐具的清潔劑。
- 清洗程序結束後，立即從洗碗碟機中取出玻璃餐具和其它餐具。

保養及維修

清潔過濾器組件

定期清潔過濾器組件，使過濾器不會堵塞，並使污水正確排出。過濾器組件由三個過濾器組成，可以清除洗滌水中的殘留物，然後再循環過濾水：為了獲得最佳的清洗效果，您需要保持過濾器清潔。

如果沒有過濾器或過濾器鬆脫，洗碗碟機將不能正常運作。多次清洗後，檢查過濾器組件，如有必要，使用非金屬刷子在水流下徹底清潔，並按照以下說明操作：

1. 沿逆時針方向轉動圓柱形過濾器A並將其拉出(圖1)。
2. 通過在側翼上施加輕微壓力來移除杯式過濾器B(圖2)。
3. 滑動不鏽鋼板式過濾器C(圖3)。
4. 檢查排水閥並清除任何殘留物。切勿拆除洗滌循環泵保護器(黑色細節)(圖4)。

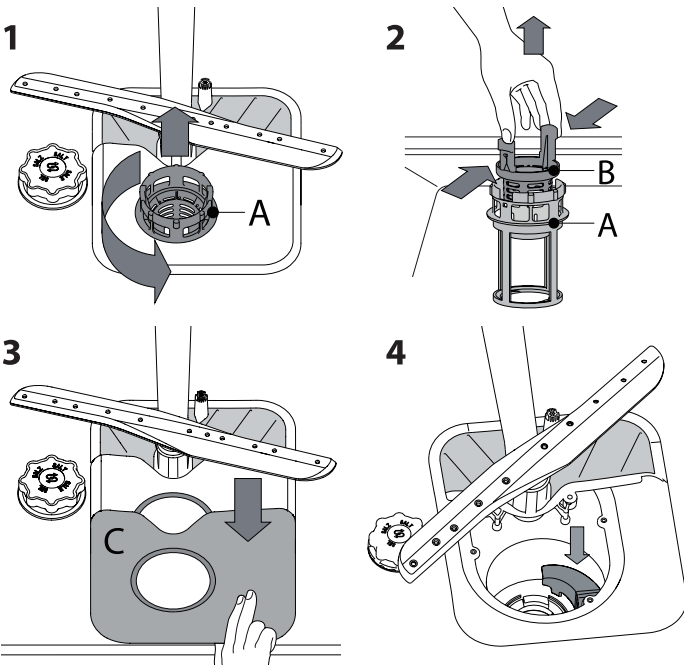

為確保洗碗碟機的運行暢順及有效，清潔過濾器後，必須重新將過濾器組件固定到正確位置。

清潔噴灑臂

食物殘渣有時可能會殘留在噴灑臂的外殼上，並堵塞噴水孔。因此，我們建議您時常檢查噴灑臂，並用細小的非金屬刷子清潔它們。

如要卸上下層噴灑臂，請按逆時針方向轉動塑料鎖緊環。裝上層噴灑臂時，使孔數較多的一側朝上。

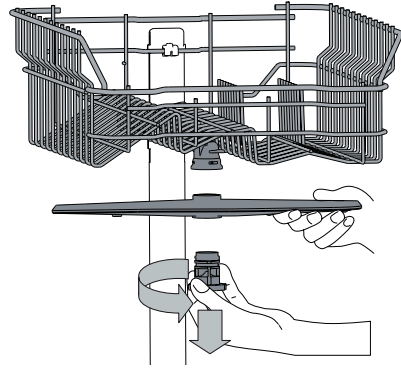

可以通過向上拉動下層噴灑臂來移除下層噴灑臂。

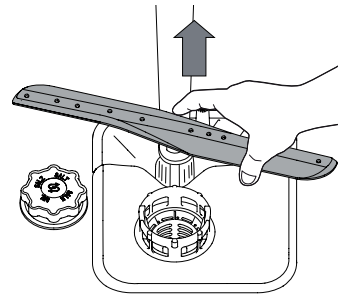

清潔進水口軟管

如果水管是新的或長時間未使用，請在進行必要的連接之前讓水運行以確保其清澈且無雜質。如果不採取這種預防措施，進水口可能會堵塞並損壞洗碗碟機。

故障排除

此洗碗碟機可能因為某些原因而不能正常運作。
聯絡售後服務中心之前，建議先自行進行檢查，看問題是否可以使用以下列表的簡易方法解決。

| 問題 | 可能原因 | 解決方法 |
|--------------------|--------------------|---|
| 洗碗碟機無法啟動或不能依據指令運作。 | 設備的電源插頭未正確連接。 | 將電源插頭插入插座。 |
| | 電源故障。 | 電源恢復後洗碗碟機會自動啟動。 |
| | 洗碗碟機的機門沒有完全關閉。 | 大力推門，直到聽到「喀嗒」一聲。 |
| | 操作沒有依據指令運作。 | 按電源「開/關 / 重設」鍵關閉設備，大約一分鐘後重新打開，然後重置程序。 |
| 洗碗碟機無法排水。 | 清洗程序尚未完成。 | 等待清洗程序結束。 |
| | 排水喉扭曲。 | 檢查排水喉確保沒有扭曲 (請參閱「安裝指引」篇章)。 |
| | 水槽的排水喉阻塞。 | 清潔水槽的排水喉。 |
| | 過濾器被食物殘渣堵塞。 | 清潔過濾器 (請參閱「清潔過濾器組件」篇章)。 |
| 洗碗碟機操作時噪音過大。 | 每套器具都在發出「叮叮噹噹」聲音。 | 正確安置餐具 (請參閱「裝置層架」篇章)。 |
| | 過多的泡沫形成。 | 未能正確測量清潔劑，或清潔劑不適合用於該洗碗碟機 (請參閱「注入清潔劑」篇章)。按「排水」鍵重置洗碗碟機 (請參閱「選項和功能」篇章)，無須加入清潔劑並重新運行程序。 |
| 餐具沒有完全潔淨。 | 餐具沒有安放適當位置。 | 正確安置餐具 (請參閱「裝置層架」篇章)。 |
| | 噴灑臂受到餐具的阻礙，不能自由旋轉。 | 正確安置餐具 (請參閱「裝置層架」篇章)。 |
| | 清洗程序太溫和。 | 選擇合適的清洗程序 (請參閱「程序表」篇章)。 |
| | 過多的泡沫形成。 | 未能正確測量清潔劑，或清潔劑不適合用於洗碗碟機 (請參閱「注入清潔劑」篇章)。 |
| | 清潔劑儲存器的蓋子未正確關閉。 | 確保清潔劑儲存器的蓋子已關閉。 |
| | 過濾器骯髒或堵塞。 | 清潔過濾器組件 (請參閱「保養及維修」篇章)。 |
| | 無加入洗碗碟機專用軟水劑。 | 加入洗碗碟機專用軟水劑 (請參閱「注入專用軟水劑」篇章)。 |

維修和故障排除指引

如要獲得更多資訊，請參閱「使用說明及安裝指南」。
「使用說明及安裝指南」可以透過以下方式獲取：

- 請致電保用證上顯示的號碼，聯絡售後服務中心。
- 於網站內可下載：www.whirlpool.com.hk

致電售後服務中心

當您致電售後服務中心前，您必須提供安裝在洗碗碟機門內左側或右側的銘牌上顯示的代碼，請致電保用證上顯示的號碼，或按照以下網址上的指引：
www.whirlpool.com.hk

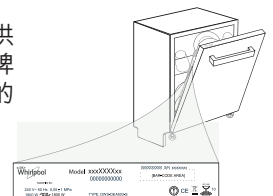

健康與安全指引

重要事項：請閱讀並遵循

使用洗碗碟機前請先細閱產品安全指引。請妥善保存此產品安全指引及使用說明作將來參考。本手冊和洗碗碟機本身提供重要的安全警告，請按需要隨時讀取及查察。不當的使用及不當的操作可能會導致的風險，製造商將不負任何責任。

⚠️ 除非得到持續監視，否則幼兒(0-3歲)和兒童(3-8歲)應遠離洗碗碟機。洗碗碟機可由8歲以上之兒童及身體、感官或精神障礙或經驗知識不足的人士操作，前提是此等人士已接受洗碗碟機的安全指導及指引，且瞭解使用洗碗碟機的相關危險。兒童不可胡亂玩弄洗碗碟機。未經指導，兒童不可進行洗碗碟機的清潔及保養工作。

允許使用

注意：此洗碗碟機不能透過外部控制器或遙控裝置進行操作。

⚠️ 此洗碗碟機設計只適用於家居或下列之類似環境：如一般商店、辦公室及其它工作環境的職員專用廚房；農莊；供入住酒店、汽車旅館及其它住宅式旅店之顧客使用；提供簡單住宿及早餐服務之旅舍。

⚠️ 此洗碗碟機最多可放置的標準餐具數目已經列明於產品說明書上。

⚠️ 洗碗碟機門不應保持常開狀態，以防有傾倒風險。洗碗碟機門只能承托拉出已負載的餐具層架時的重量。不要擺放任何物件、坐或站立於洗碗碟機門上。

⚠️ 警告：洗碗碟機清潔劑帶有強烈鹼性。若吞下，可造成嚴重危險。應避免清潔劑接觸皮膚及眼睛，並令兒童遠離已打開機門的洗碗碟機。清洗程序完結後，應清空清潔劑儲存器。

⚠️ 警告：刀及其它帶有鋒利邊緣的器皿及餐具必須刀尖朝下水平放置於餐具層架，避免割傷風險。

⚠️ 此洗碗碟機並非用作專業用途。請勿於室外使用此產品。洗碗碟機內及洗碗碟機旁邊切勿擺放具爆炸性或易燃的物件(例如燃油或壓縮噴霧罐)，避免起火風險。

此洗碗碟機只適用於按照此產品說明書指引下清洗家居碗碟。洗碗碟機內的水不能飲用。

請只使用專為洗碗碟機而設的洗碗碟機專用清潔劑及吹乾劑。

當加入洗碗碟機專用軟水劑後，立即於無負載的情況下運行一次清洗程序，可避免因腐蝕而損壞內部機件。請把洗碗碟機專用清潔劑、吹乾劑及軟水劑存放於兒童不能觸及的地方。

於檢查及維修洗碗碟機前，請先關閉供水水喉，並切斷電源。當遇到機件故障，亦應立即切斷洗碗碟機的供水及供電。

安裝

⚠️ 此洗碗碟機建議由兩個或更多的人進行安裝處理，避免受傷風險。使用防護手套來執行所有拆封和安裝操作，避免割傷風險。

必須使用新水喉管將洗碗碟機連接至主水管。不能重用舊的水喉管。洗碗碟機運行過程中必須確保所有水喉安全裝上，防止鬆脫。必須遵循本地水公司的法規連接水喉管。供水壓力介乎0.05至1.0MPa之間。

洗碗碟機必須靠牆放置或內置於廚櫃內，以確保機件背部不會被觸碰。於底部備有通風口的洗碗碟機，必須確保地毯沒有阻擋或覆蓋通風口。

⚠️ 安裝，包括供水(如有)及電線接駁，必須由合資格的技術人員按照製造商的說明和本地標準安全法規進行維修。除非在用戶手冊特別聲明，切勿維修或更換任何洗碗碟機的部件。兒童應遠離洗碗碟機安裝地點。拆開洗碗碟機後，確認它沒有在運輸過程中損壞。在出現問題時，請聯絡經銷商或售後服務中心。

當完成安裝後，包裝材料(如塑膠、發泡膠件等)，應置於幼童無法取得的地方，避免意外的風險。此洗碗碟機進行安裝前，必先斷開它的電源連接避免觸電危險。進行安裝時，確保洗碗碟機電源線沒有損壞，避免火災或觸電危險。只有當安裝步驟完成後才可啟動洗碗碟機。

若洗碗碟機被安裝在廚櫃末端，令側面板外露，必須遮蓋鉸鏈位置，避免受傷風險。

進水溫度視乎洗碗碟機型號而定。入水喉上標注「最高25°C」，則表示最高進水溫度是25°C，其他沒有標示的型號，最高進水溫度是60°C。

請勿修剪水喉。若洗碗碟機備有防溢系統，請勿把入水喉的塑膠包裝浸入水中。

若喉管不夠長，請聯絡本地經銷商。請確保入水喉及出水喉沒有出現打結及被擠壓的情況。於首次使用洗碗碟機前，請檢查入水喉及出水喉有沒有漏水。

確保洗碗碟機的四隻腳穩固坐落在地面上，如有需要，可作調整，並檢查洗碗碟機是否完全處於水平位置(利用水平尺量度)。

電氣警告

銘牌位於洗碗碟機機門的邊緣(當洗碗碟機機門打開時就能看見)。

⚠ 插座必須能夠拔掉，以切斷電源，或安裝設有開關鍵的插座及按照本地的電器安全標準法連接地線。

⚠ 請勿使用接駁電線或萬能插座，安裝後電線部份不可被使用者易於接觸。手濕或赤腳時請勿使用本產品。若本產品的電源線或插頭有損壞，不能正常運作，或受損，請勿操作。

⚠ 如果電源線損壞，必須根據相同產品更換電源線。電源線只能由製造商指定的技術人員更換以避免觸電的危險。

若洗碗碟機所配置的插頭與插座不相配，請聯絡合資格技術人員。切勿拉扯電源線。

請不要將電源線及插頭浸於水中。應保持電源線遠離高溫的表面。

清潔和保養

⚠ 警告：執行任何維修或清潔操作之前，請先關閉及拔下電源插頭，避免觸電風險。切勿使用蒸氣清洗本產品。

處理包裝物料

包裝材料完全可回收，並設有可回收標誌 ：包裝的各個部分必須根據當前本地廢品處理法規進行處理。

廢棄家用電器

必須根據當前本地廢品處理法規進行處理。有關處理、修復和回收本產品的詳細資訊，請聯繫售後服務中心、家庭廢品處理服務中心或您購買本產品的商店。

本洗碗碟機依照有關廢棄電器和電子設備(WEEE)的歐盟標準 2012/19/EU 標示。確保以正確的方式廢棄本產品，可避免因不當的廢棄處理方式而對環境和人體健康造成潛在的負面影響。

這符號  表示此機器不能作為家庭廢品處理。應將它交給回收電器和電子設備的適用收集點。

節約能源貼士

省電洗：這是標準清洗程序，適用於清洗一般骯髒的餐具，這亦是在能源消耗和耗水量方面，綜合消耗的結果來看，效率最高的清洗程序。

安裝指引

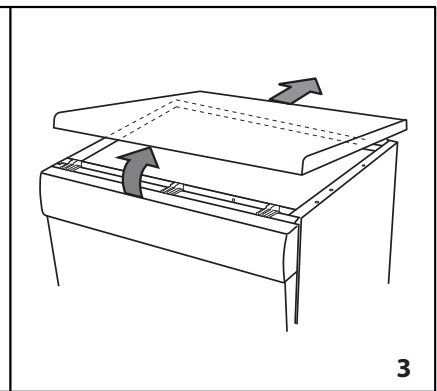
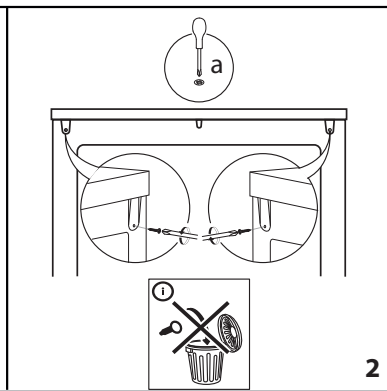
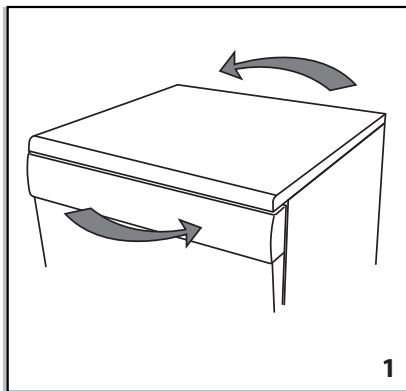
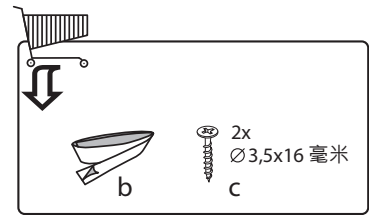
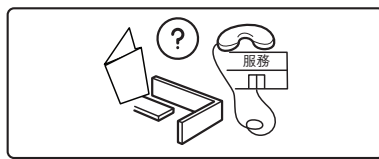
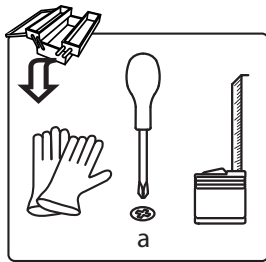
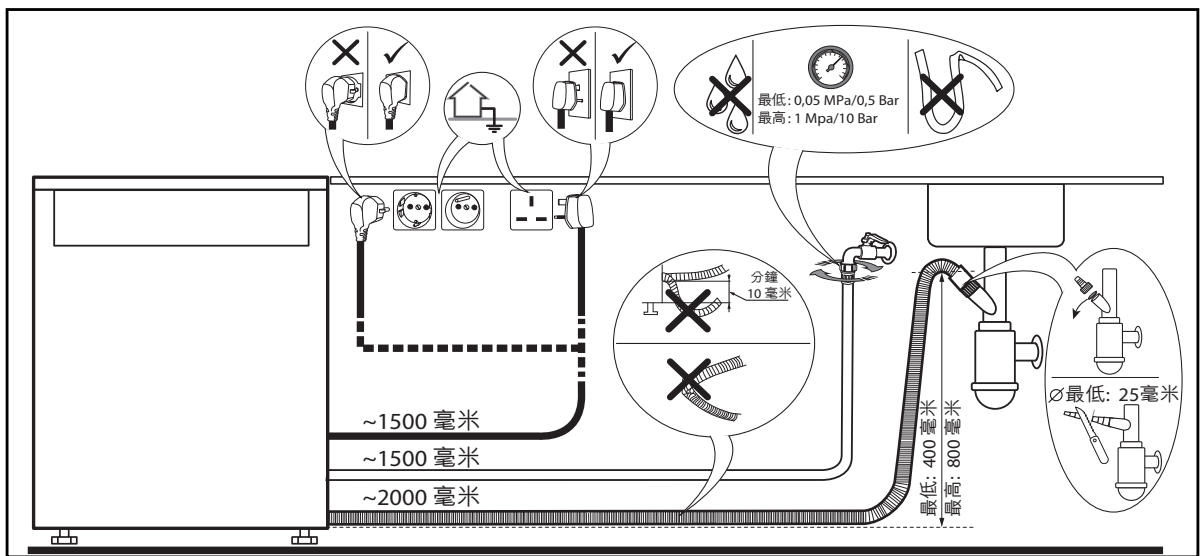
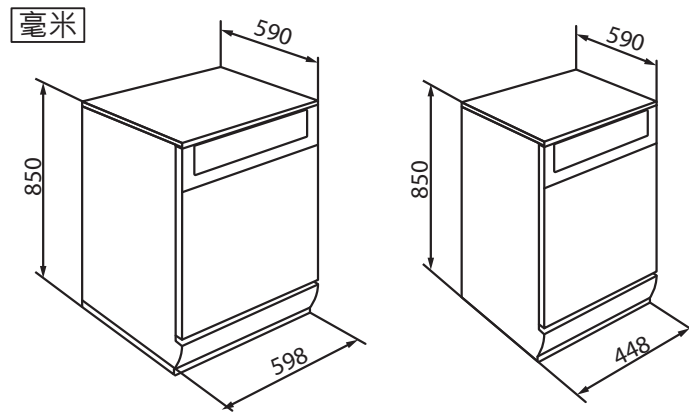

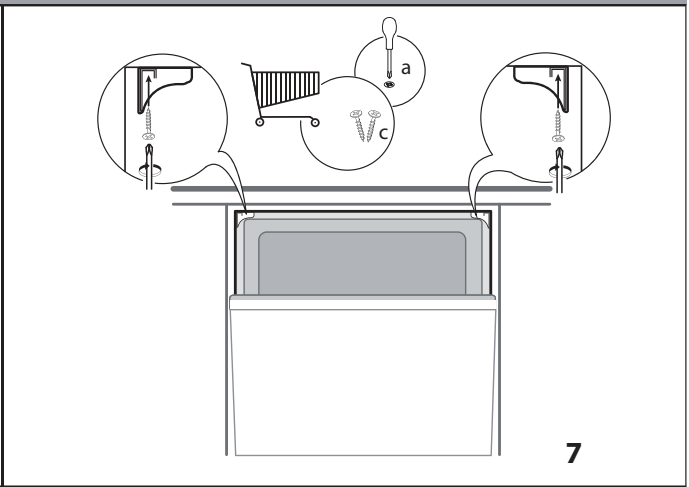
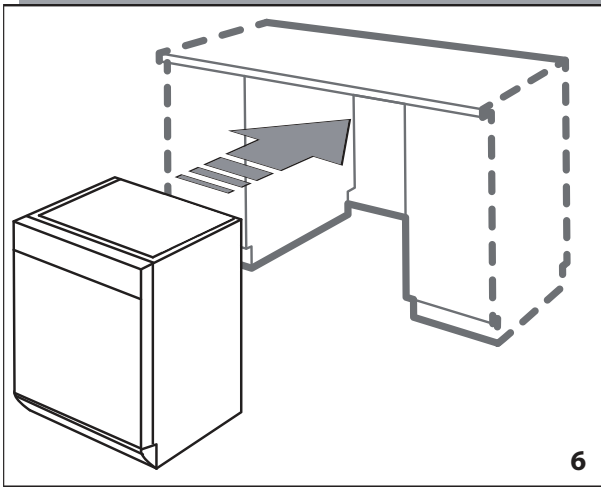
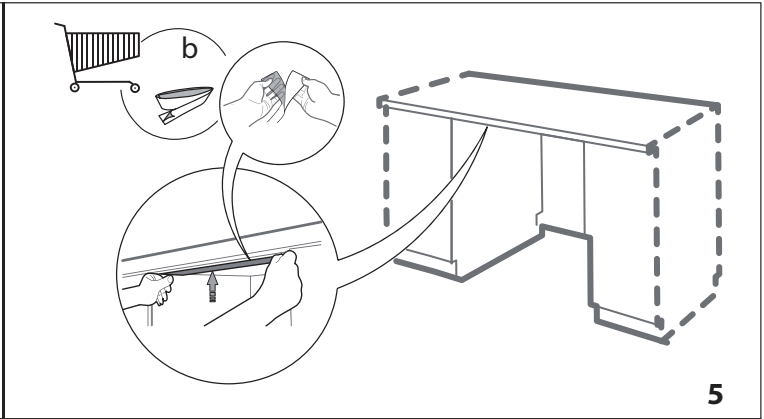
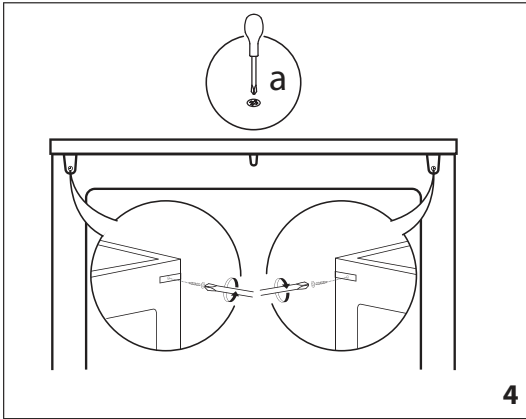

Whirlpool® Registered trademark/TM Trademark of Whirlpool group of companies
 All rights reserved - <http://www.whirlpool.com.hk>

Whirlpool® 註冊商標 / 惠而浦集團的TM商標
 版權所有 翻印必究 - <http://www.whirlpool.com.hk>

