

Whirlpool

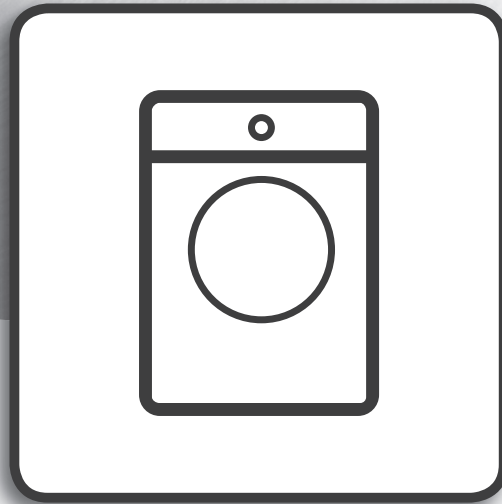

Health & Safety, Use & Care and Installation guide
產品安全指引、使用說明及安裝指南

Model : WFCR 96430

產品型號 : WFCR 96430



www.whirlpool.com.hk

ENGLISH 3

繁體中文 26

ENGLISH

USER MANUAL



THANK YOU FOR BUYING AN WHIRLPOOL PRODUCT.
For even more complete user support, register your
appliance at www.whirlpool.com.hk

Index

Health and Safety guide

SAFETY INSTRUCTIONS	5
IMPORTANT TO BE READ AND OBSERVE.....	5

User manual

PRODUCT DESCRIPTION	7
APPLIANCE	7
CONTROL PANEL.....	7
DETERGENT DISPENSER	8
TECHNICAL SPECIFICATIONS FOR THE WATER CONNECTION	9
DOOR	9
HOW TO USE THE APPLIANCE.....	10
FIRST TIME USE	10
DAILY USE	10
HINTS AND TIPS.....	12
PROGRAMME CHART.....	13
PROGRAMMES.....	14
OPTIONS AND FUNCTIONS.....	15
CLEANING AND MAINTENANCE.....	16
CLEANING THE WASHER DRYER EXTERNALLY.....	16
CHECKING THE WATER INTAKE HOSE.....	17
CLEANING THE FILTERS IN THE WATER INTAKE HOSE	18
CLEANING THE DETERGENT DISPENSER.....	19
CLEANING THE WATER FILTER / DRAINING THE RESIDUAL WATER.....	20

TRANSPORT AND HANDLING.....	22
TROUBLESHOOTING	23
CUSTOMER SUPPORT SERVICE.....	25
INSTALLATION GUIDES	49

SAFETY INSTRUCTIONS

Before using the appliance, read these safety instructions. Keep them nearby for future reference. These instructions and the appliance itself provide important safety warnings, to be observed at all times. The manufacturer declines any liability for failure to observe these safety instructions, for inappropriate use of the appliance or incorrect setting of controls.

⚠ Very young children (0-3 years) should be kept away from the appliance. Young children (3-8 years) should be kept away from the appliance unless continuously supervised. Children from 8 years old and above and persons with reduced physical, sensory or mental capabilities or lack of experience and knowledge can use this appliance only if they are supervised or have been given instructions on safe use and understand the hazards involved. Children must not play with the appliance. Cleaning and user maintenance must not be carried out by children without supervision. Never open the door forcibly or use it as a step.

PERMITTED USE

⚠ **CAUTION:** The appliance is not intended to be operated by means of an external switching device, such as a timer, or separate remote controlled system.

⚠ This appliance is intended to be used in household and similar applications such as: staff kitchen areas in shops, offices and other working environments; farm houses; by clients in hotels, motels, bed & breakfast and other residential environments.

⚠ Do not load the machine above the maximum capacity (kg of dry cloth) indicated in the programme table.

⚠ This appliance is not for professional use. Do not use the appliance outdoors.

⚠ Do not use any solvents (e.g. turpentine, benzene), detergents containing solvents, scouring powder, glass or general purpose cleaners, or flammable fluids; do not machine wash fabrics that have been treated with solvents or flammable liquids.

⚠ Do not dry unwashed items in the tumble dryer.

⚠ Items that have been soiled with substances such as cooking oil, acetone, alcohol, petrol, kerosene, spot removers, turpentine, waxes and wax removers should be washed in hot water with an extra amount of detergent before being dried in the tumble dryer.

IMPORTANT TO BE READ AND OBSERVE

⚠ Items such as foam rubber (latex foam), shower caps, waterproof textiles, rubber backed articles and clothes or pillows fitted with foam rubber pads should not be dried in the tumble dryer.

⚠ Fabric softeners, or similar products, should be used as specified by the fabric softener instructions.

⚠ The final part of a tumble dryer cycle occurs without heat (cool down cycle) to ensure that the items are left at a temperature that ensures that the items will not be damaged.

⚠ Never stop a tumble dryer before the end of the drying cycle unless all items are quickly removed and spread out so that the heat is dissipated.

⚠ During the drying phase, the door tends to get quite hot.

⚠ Do not use the appliance to dry clothes that have been washed with flammable solvents (e.g. trichlorethylene).

⚠ Do not use the appliance to dry foam rubber or similar elastomers.

⚠ Make sure that the water tap is turned on during the drying cycles.

⚠ Remove all objects from pockets such as lighters and matches.

INSTALLATION

⚠ The appliance must be handled and installed by two or more persons - risk of injury. Use protective gloves to unpack and install - risk of cuts.

If you want to stack a dryer on top of your washing machine, first contact our After-Sales Service or your specialist dealer to verify whether this is possible. This is only possible if the dryer is attached to the washing machine by means of appropriate stacking kit available through our After-Sales Service or your specialist dealer.

⚠ Move the appliance without lifting it by the worktop or top lid.

⚠ Installation, including water supply (if any) and electrical connections and repairs must be carried out by a qualified technician. Do not repair or replace any part of the appliance unless specifically stated in the user manual. Keep children away from the installation site. After unpacking the appliance, make sure that it has not been damaged during transport. In the event of problems, contact the dealer or your nearest After-sales Service. Once installed, packaging waste (plastic, styrofoam parts etc.)

must be stored out of reach of children - risk of suffocation. The appliance must be disconnected from the power supply before any installation operation - risk of electric shock. During installation, make sure the appliance does not damage the power cable - risk of fire or electric shock. Only activate the appliance when the installation has been completed.

⚠ Do not install your appliance where it may be exposed to extreme conditions, such as: poor ventilation, temperatures below 5 °C or above 35 °C.

⚠ When installing the appliance make sure that the four feet are stable and resting on the floor, adjusting them as required, and check that the appliance is perfectly level using a spirit level.

⚠ If the appliance is being installed on wood or "floating" floors (certain parquet and laminate materials), secure a 60 x 60 x 3 cm (at least) sheet of plywood to the floor then place the appliance on top of this.

⚠ Connect the water inlet hose(s) to the water supply in accordance with the regulations of your local water company.

⚠ For cold fill only models: do not connect to the hot water supply.

⚠ For models with hot fill: the hot water inlet temperature must not exceed 60 °C.

⚠ The washing machine is fitted with transport bolts to prevent any possible damage to the interior during transport. Before using the machine, it is imperative that the transport bolts are removed. After their removal, cover the openings with the 4 enclosed plastic caps.

⚠ After installation of the device, wait a few hours before starting it so that it acclimates to the environmental conditions of the room.

⚠ Make sure that the ventilation openings in the base of your washing machine (if available on your model) are not obstructed by a carpet or other material.

⚠ Use only new hoses to connect the appliance to the water supply. The old hose-sets should not be reused.

⚠ The supply water pressure must be in the 0.1-1 Mpa range.

ELECTRICAL WARNINGS

⚠ It must be possible to disconnect the appliance from the power supply by unplugging it if plug is accessible, or by a multi-pole switch installed upstream of the socket in accordance with the wiring rules and the appliance must be earthed in conformity with national electrical safety standards.

⚠ Do not use extension leads, multiple sockets or adapters. The electrical components must not be accessible to the user after installation.

Do not use the appliance when you are wet or barefoot. Do not operate this appliance if it has a damaged power cable or plug, if it is not working properly, or if it has been damaged or dropped.

⚠ If the supply cord is damaged, it must be replaced with an identical one by the manufacturer, its service agent or similarly qualified persons in order to avoid a hazard - risk of electric shock.

CLEANING AND MAINTENANCE

⚠ **WARNING:** Ensure that the appliance is switched off and disconnected from the power supply before performing any maintenance operation; never use steam cleaning equipment - risk of electric shock.

DISPOSAL OF PACKAGING MATERIALS

The packaging material is 100% recyclable and is marked with the recycle symbol .

The various parts of the packaging must therefore be disposed of responsibly and in full compliance with local authority regulations governing waste disposal.

DISPOSAL OF HOUSEHOLD APPLIANCES

This appliance is manufactured with recyclable or reusable materials. Dispose of it in accordance with local waste disposal regulations. For further information on the treatment, recovery and recycling of household electrical appliances, contact your local authority, the collection service for household waste or the store where you purchased the appliance. This appliance is marked in compliance with European Directive 2012/19/EU, Waste Electrical and Electronic Equipment (WEEE). By ensuring this product is disposed of correctly, you will help prevent negative consequences for the environment and human health.

The symbol  on the product or on the accompanying documentation indicates that it should not be treated as domestic waste but must be taken to an appropriate collection center for the recycling of electrical and electronic equipment.



PRODUCT DESCRIPTION

APPLIANCE

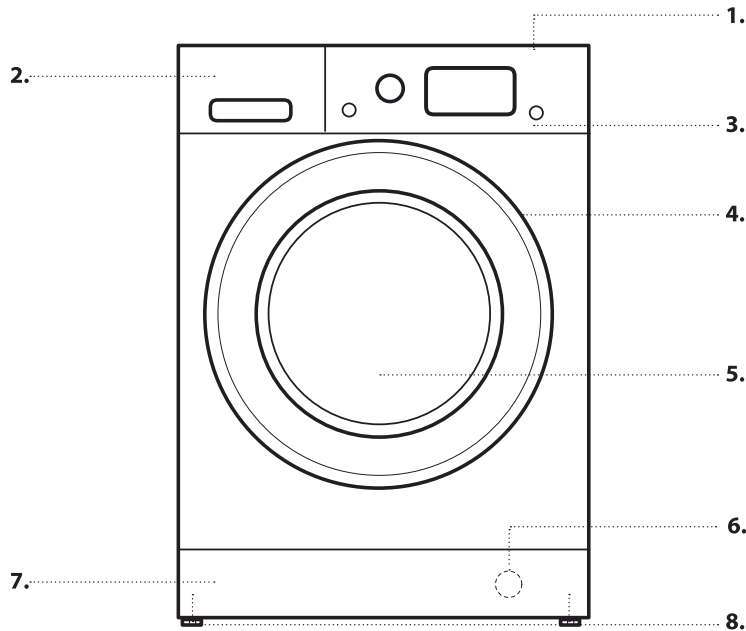

1. Top
2. Detergent dispenser
3. Control Panel
4. Lid handle
5. Door
6. Water filter - behind kick panel
7. Removable kick panel
8. Adjustable feet (2)

CONTROL PANEL

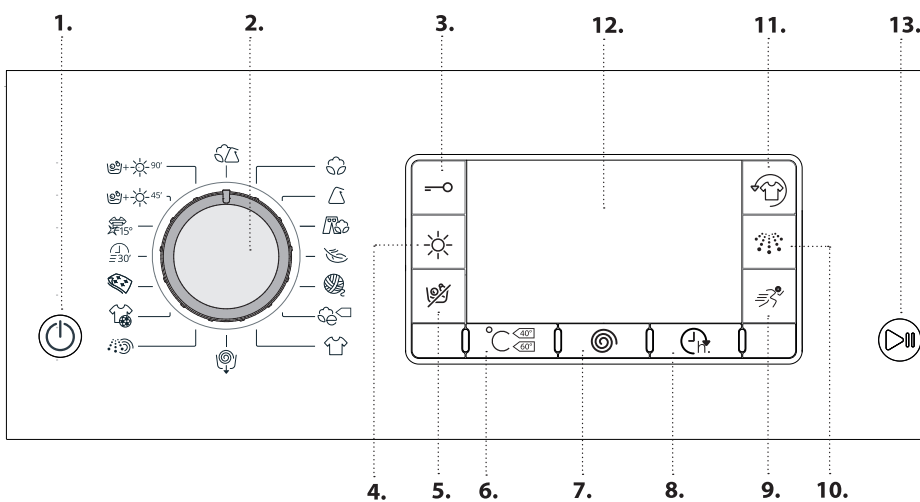

1. On/Off button
2. Programme selector
3. Key Lock button
4. Drying settings button
5. Dry Only Button
6. Temperature button
7. Spin button
8. Delay timer button
9. Rapid button
10. Intensive Rinse button
11. FreshCare+ button
12. Display
13. Start/Pause button

DETERGENT DISPENSER

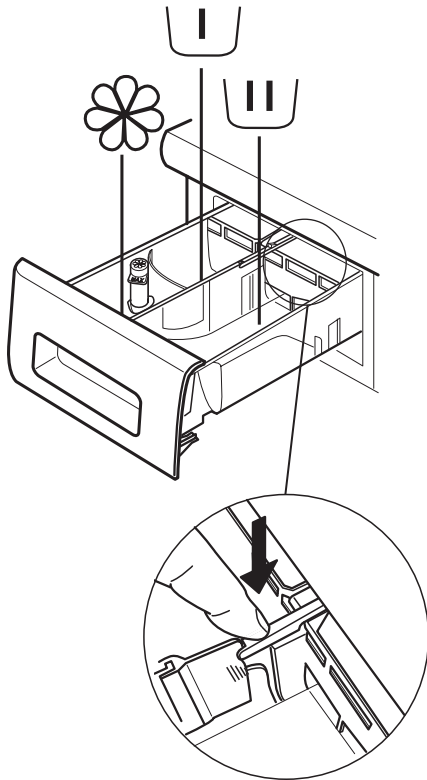

Prewash Compartment
• Detergent for prewash



Main Wash Compartment
• Detergent for the main wash
• Stain remover
• Water softener



Softener compartment
• Softener
• Liquid starch
Pour softener or starch solution into the compartment without exceeding the "max" level.

Release button
(press to remove tray for cleaning).

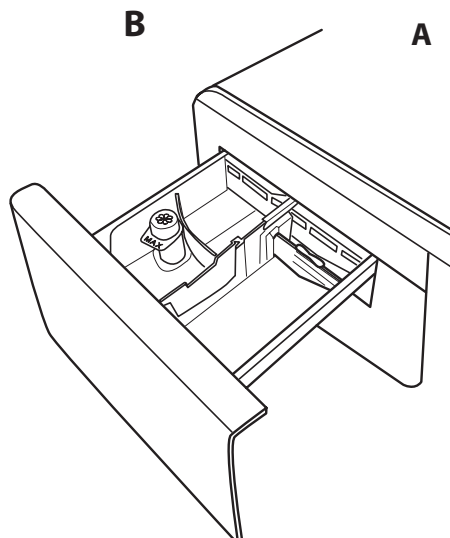

Preferably use the partition **A** when washing with a liquid detergent for washing, to ensure that the correct quantity of detergent is used (the partition is included in the bag containing the instructions).
Move the partition into slot **B** when using detergent powder.

TECHNICAL SPECIFICATIONS FOR THE WATER CONNECTION

INPUT WATER	Cold
WATER TAP	Threaded attachment for 3/4" flexible hose
MINIMUM WATER INTAKE PRESSURE	100 kPa (1 bar)
MAXIMUM WATER INTAKE PRESSURE	1000 kPa (10 bar)

DOOR

To open the door, pull the handle.

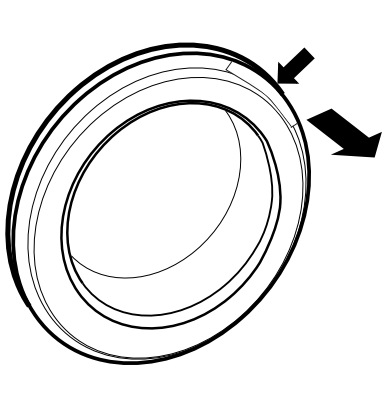



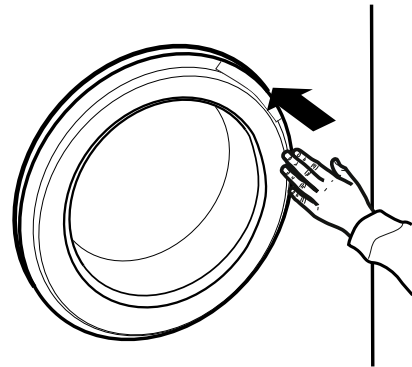

To close the door, push on the handle until it clicks.







HOW TO USE THE APPLIANCE

FIRST TIME USE

See the section *DAILY USE* for instructions on selecting and starting a programme.



The first time the machine is switched on, you will be asked to select the language and the display will automatically show the language selection menu. To select the desired language press the °C and  buttons; to confirm the selection press the  button. To change the language switch off the machine and press buttons , ,  simultaneously until an alarm is heard: the language-selection menu will be displayed again.

To change the display luminosity, which by default is set to the medium value, switch the machine off then simultaneously press buttons ,  and  until the buzzer sounds. Press buttons °C and  to choose the desired level of luminosity then confirm by pressing button .

DAILY USE

For more information on functions, a more detailed guide may be requested or downloaded from the website following the instructions given on the last page.

1. LOADING LAUNDRY.



- Prepare the laundry, following the recommendations given in the section "HINTS AND TIPS". - Open the door and load the laundry into the drum, without exceeding the maximum load capacities indicated in the *Programme Chart*. 
- Close the door, pressing until the latch audibly locks, and check that there is no laundry trapped between the door glass and the rubber seal.  

2. OPEN THE WATER TAP

Check that the washer dryer is connected correctly to the water mains. Open the water tap. 

FIRST CYCLE OPERATION

Remove any manufacturing debris:

1. Select the  programme with a temperature setting of 60 °C.
2. Pour a small quantity of detergent powder into the main wash compartment of the detergent dispenser (maximum 1/3 of the quantity the detergent manufacturer recommends for lightly soiled laundry). 
3. Start the programme **without loading the washer dryer machine** (with empty drum).

3. SWITCHING ON THE WASHER DRYER MACHINE.

Press button ; the lamp  flashes slowly.

4. SELECTING A PROGRAMME AND CUSTOMISING A CYCLE.

The following functions are possible with this appliance:

- Wash only
- Wash and dry
- Dry only

Wash only

Select the required programme with the PROGRAMME selector dial. The display will show the name and duration of the cycle. The washer dryer machine automatically displays the maximum temperature and spin speed settings possible for the selected programme. Adjust the temperature and/or spin speed settings if needed with the relative buttons.

- Press button °C to cycle through progressively lower temperature settings until cold wash is set ("-" shown on display).
- Press button  to cycle through progressively lower spin speed settings until the spin cycle is turned off ("-" shown on display). Pressing the button again sets the highest possible setting.

Select the required options (if necessary).

- Press the button to select the option; the respective button lamp illuminates.
- Press the button again to cancel the option; the lamp extinguishes.

! If the selected option is not compatible with the programme set, an error warning tone sounds and the wording "No Selection" is shown on the display. The option is not selected.

Wash and dry

To wash and dry a load with no interruption between the wash and dry cycles, make sure that the load does not exceed the maximum permissible drying load for the selected programme (see the column "Max. load for drying cycle" in the *Programme chart*).

1. Follow the instructions given in the paragraph "Wash Only" to select and, if necessary, customise the required programme.
2. Press  to select the required drying mode. Two drying modes are available: automatic or timer.

- Automatic drying with selectable levels:

In automatic drying mode, the washer dryer machine dries the laundry until the set level of dryness is reached. Pressing button  once automatically selects the highest drying level available for the selected programme. Press the button again to reduce the drying level.

The following levels are available:



Cupboard extra dry : suitable for garments which need to be dried completely, such as sponges and bathrobes.

Cupboard dry : laundry is completely dry and ready to be put away in the wardrobe without ironing.

Hanger dry : laundry is left slightly damp to minimise creasing. Garments must be hung to air dry completely.

Iron dry : garments are left reasonably damp to make ironing easier.

- Timer drying mode:

Press button  repeatedly to set timer drying mode. After cycling through all the automatic drying levels, continue pressing button  until the desired time is displayed. Values from 180 to 30 minutes are settable.

To wash a load of laundry larger than the maximum permissible load for drying (see the column "Max. load for drying cycle" in the *Programme chart*), remove a few garments once the washing cycle has finished before starting the drying cycle. Proceed as follows:



1. Follow the instructions given in the paragraph "Wash Only" to select and, if necessary, customise the required programme.
2. Do not include a drying cycle.
3. Once the washing cycle is finished, open the door and remove a few garments to reduce the load. Now follow the instructions for "Dry only".

N.B.: always allow a cooling down period after drying before opening the door.

When using the two preset cycles  and  it is not necessary to select and start a drying cycle.

Dry only

This function is used to simply dry a wet load washed previously in the washer dryer or by hand.

1. Select a suitable programme for the laundry you want to dry (e.g. select cotton to dry wet cotton laundry).
2. Press button  to dry without a wash cycle.
3. Press  to select the required drying mode. Two drying modes are available: automatic drying by levels or drying by time.

- Automatic drying with selectable levels:

In automatic drying mode, the washer dryer machine dries the laundry until the set level of dryness is reached. Pressing button  once automatically selects the highest drying level available for the selected programme. Press the button again to reduce the drying level.

The following levels are available:

Cupboard extra dry : suitable for garments which need to be dried completely, such as sponges and bathrobes.

Cupboard dry : laundry is completely dry and ready to be put away in the wardrobe without ironing.

Hanger dry : laundry is left slightly damp to minimise creasing. Garments must be hung to air dry completely.

Iron dry : garments are left reasonably damp to make ironing easier.



- Timer drying mode:

Press button  repeatedly to set timer drying mode. After cycling through all the automatic drying levels, continue pressing button  until the desired time is displayed.

Values from 180 to 30 minutes are settable. N.B.: always allow a cooling down period after drying before opening the door.

5. **USING THE CORRECT AMOUNT OF DETERGENT.** Pull out the tray and pour detergent into the relative compartments as described in "Detergent dispenser". This is only necessary when using a wash only or a wash + dry programme.

6. **DELAYING THE START OF A PROGRAMME.** To set a programme to start at a later time, see the section "Options and Functions".

7. **STARTING A PROGRAMME.** Press the START/PAUSE button. The relative indicator lamp illuminates, the door locks and the door open  symbol extinguishes. To change a programme while a cycle is in progress, press START/PAUSE to pause the washer dryer (the START/ PAUSE lamp flashes amber slowly); then select the required cycle and press START/PAUSE again. To open the door while a cycle is in progress, press START/PAUSE; the door may be opened if the  symbol lights. Press the START/PAUSE button again to resume the programme from where it was paused.

8. CANCELLING A RUNNING PROGRAMME (IF NECESSARY)



Press and hold the button  until the washer dryer stops.

If the water level and temperature are low enough, the door unlocks and may be opened. The door remains locked if there is water in the drum. To unlock the door, switch the washer dryer on, select the

 programme and turn the spin function off by setting the spin speed to “- -”. The water is emptied and the door unlocks at the end of the programme.

9. SWITCHING THE WASHER DRYER OFF AT THE END OF A PROGRAMME.

At the end of the cycle, the message “Cycle end” is shown on the display. The door can only be opened when the  symbol lights. Check that the door unlocked symbol is lit, then open the door and take out the laundry.

Press  to switch the washer dryer off. To save energy, if the washer dryer is not switched off manually with the  button, it turns off automatically approximately 30 minutes after the end of the programme.

Leave the door ajar to let the interior of the washer dryer dry.

HINTS AND TIPS

RULES FOR SEPARATING LAUNDRY





- Fabric type / indications on label (cotton, mixed fibres, synthetic, wool, handwash items)
- Colour (separate coloured garments from whites, wash new coloured items separately)
- Size (wash items of different sizes in the same load to improve washing efficacy and weight distribution in the drum)
- Delicates (place small items – such as nylon stockings – and garments with clasps – such as braziers – in a laundry bag or in a pillow case with a zip).

EMPTY POCKETS

- Objects such as coins or safety pins can damage laundry and the washer dryer drum.

WASH SYMBOLS ON GARMENT LABELS

The value given in the tub symbol is the maximum temperature possible for washing the garment.

-  Normal mechanical action
-  Reduced mechanical action
-  Much reduced mechanical action
-  Hand wash only
-  Do not wash

CLEAN THE WATER FILTER REGULARLY

- This is needed to prevent the filter from blocking and preventing the water from draining correctly. See the section “Cleaning and Maintenance” / “Cleaning the water filter” in the detailed guide that may be requested or downloaded from the website.

SAVING ENERGY AND PROTECTING THE ENVIRONMENT

- Keeping within the load limits indicated in the programme chart will optimise energy, water and detergent consumption and reduce washing times.
- Do not exceed the detergent quantities recommended by the detergent manufacturer.
- Save energy by using a 60°C instead of a 90°C wash programme, or by using a 40°C instead of a 60°C wash programme. We recommend using the  60°C programme for cotton garments, which is longer but uses less energy.
- To save energy and time when washing and drying, select highest spin speed available for the programme to reduce the residual water remaining in the garments at the end of the wash cycle.

PROGRAMME CHART

Programme	Available temperatures	Max. spin speed (rpm)	Dry Only	Max. load for wash cycle (kg)	Max. load for drying cycle (kg)	Default wash cycle Duration (H:MM)	Fresh Care +	Intensive Rinse	Rapid	Detergents and additives			Recommended detergent	
										Prewash	Main	Softener	Powder	Liquid
MIXED	☀ - 40°C	1000	✓	4.5	4.5	0:59	✓	✓	✓	-	●	○	-	✓
COTTON (2)	☀ - 60°C	1400	✓	9	6	3:55	-	-	-	-	●	○	✓	✓
SYNTHETICS	☀ - 60°C	1200	✓	4.5	4.5	3:25	✓	✓	-	-	●	○	✓	✓
JEANS	☀ - 40°C	800	✓	4	4	1:35	-	✓	-	-	●	○	-	✓
DELICATES	☀ - 30°C	--	✓	1	1	1:10	-	-	-	-	●	○	-	✓
WOOL	☀ - 40°C	800	✓	2	2	1:35	-	✓	-	-	●	○	-	✓
ECO COTTON (1)	☀ - 60°C	1400	✓	9	6	3:40	✓	-	-	-	●	○	✓	✓
ECO COTTON	☀ - 40°C	1400	✓	9	6	3:55	-	-	-	-	●	○	✓	✓
WHITES	☀ - 90°C	1400	✓	9	6	2:40	✓	✓	✓	● (90°)	●	○	✓	-
SPIN + DRAIN *	-	1400	✓	9	6	0:10	-	-	-	-	-	-	-	-
RINSE + SPIN	-	1400	✓	9	6	0:50	-	✓	-	-	-	○	-	-
SPORT	☀ - 40°C	600	✓	4	4	1:45	✓	✓	-	-	●	○	-	✓
DUVET	☀ - 30°C	1000	-	2.5	-	2:00	-	✓	-	-	●	○	-	✓
RAPID 30'	☀ - 30°C	800	-	3.5	-	0:30	✓	-	-	-	●	○	-	✓
COLOURS 15°	15°C	1000	✓	4.5	4.5	1:30	✓	✓	-	-	●	○	-	✓
WASH & DRY 45'	30°C	1400	✓	1	1	0:45	-	-	-	-	●	○	-	✓
WASH & DRY 90'	30°C	1200	✓	2	2	1:30	-	-	-	-	●	○	-	✓

✓ Selectable/optional - Not selectable/applicable ● Required quantity ○ Optional quantity

For wash programmes with temperatures above 50°C, we recommend using powder detergent rather than liquid, and following the directions given on the detergent package.

* Select the programme and set the spin speed to "--" to empty only.

- 1) Test programme in compliance with standard EN 50229 (Wash): select the programme with a temperature of 60°C.
- 2) Long cotton programme: set the programme with a temperature of 40°C.

Test programme in compliance with standard EN 50229 (Drying): select the wash programme and set the drying level to "1", for both loads. The first drying cycle must be carried out with the nominal load.

The cycle duration indicated on the display or in the manual is an estimated time calculated for standard conditions. The actual cycle time may vary in relation to a number of different factors, such as inlet water temperature and pressure, ambient temperature, quantity of detergent, size and type of load, load balancing and any additional optional functions selected.

PROGRAMMES

Follow the directions indicated in the garment wash symbols.

MIXED

for washing lightly to normally soiled resilient garments in cotton, linen, synthetic fibres and mixed fibres.

COTTON

for washing normally to heavily soiled towels, underwear, table and bed linen etc. in resilient cotton and linen.

SYNTHETICS

for washing normally soiled garments made from synthetic fibres (such as polyester, polyacrylic, viscose etc.) or cotton/synthetic blends.

JEANS

Turn garments inside-out before washing and use a liquid detergent.

DELICATES

for washing particularly delicate garments. Preferably turn garments inside out before washing.

WOOL

All wool garments can be washed using programme "Wool" even those carrying the "hand-wash only" label. For best results, use special detergents and **do not exceed max kg declaration of laundry.**

ECO COTTON

for washing normally soiled cotton garments. At 40°C and 60°C, this is the standard cotton programme and the most efficient in terms of water and energy consumption.

WHITES

For washing normally to heavily soiled towels, underwear, table and bed linen, etc in resilient cotton and linen. Only when the temperature is selected at 90°C the cycle is provided with a prewash phase before main washing phase. In this case it is recommended to add detergent both, in the prewash and main wash section.

SPIN + DRAIN

spins the load then empties the water. For resilient garments.

RINSE + SPIN

rinses and then spins. For resilient garments.

SPORT

for washing lightly soiled sports clothing (tracksuits, shorts, etc.); for best results, we recommend not exceeding the maximum load indicated in the "Programme chart". We recommend using liquid detergent, and adding the amount suitable for a

DUVET

designed for washing eiderdown padded items such as double or single duvets, cushions and anoraks. It is recommended to load such padded items in the drum with the edges folded inwards and not to exceed $\frac{3}{4}$ of the drum's volume. For optimal washing, we recommend using a liquid detergent.

RAPID 30'

for washing lightly soiled garments quickly: this cycle lasts only 30 minutes, saving time and energy. Maximum load 4 Kg.

COLOURS 15°

This cycle helps protect colours by washing in cold water (15°C) and uses less energy to heat the water while still offering satisfactory wash results. Suitable for lightly soiled, unstained garments. This cycle offers wash results comparable to 40°C mixed at just 15°C.

WASH & DRY 45'

for washing and drying lightly soiled cotton and synthetic fibre garments quickly. This cycle washes and dries a laundry load of up to 1 Kg in just 45 minutes.

WASH & DRY 90'

for washing and drying cotton and synthetic fibre garments quickly. This cycle washes and dries a laundry load of up to 2 Kg in just 90 minutes.

OPTIONS AND FUNCTIONS

OPTIONS selectable directly by pressing the relative button

! If the selected option is not compatible with the programme set, an error warning tone sounds and the wording "No Selection" is shown on the display. The option is not selected.



FRESHCARE+

If associated with wash cycles, this option increases their performances by generating steam to block proliferation of the main sources of unpleasant odours inside the appliance (exclusively for the wash). After the steam phase, the machine runs a delicate cycle with slow drum rotations. When the FRESHCARE+ option is associated with drying cycles, it prevents stubborn creases from stabilising on garments, thanks to slow drum rotations. The FreshCare+ cycle starts at the end of the wash or drying cycle and continues for maximum 6 hours; it can be interrupted at any time by pressing any button on the control panel, or by turning the knob. Wait roughly 5 minutes before opening the door.



INTENSIVE RINSE

Option makes it possible to select the desired rinse type for sensitive skin. Press the button once for the "Extra +1" level, which makes it possible to select an additional rinse after the standard cycle rinse and remove all traces of detergent. Press the button again for the "Extra +2" level, which makes it possible to select two additional rinses to the standard cycle rinses; it is recommended for very sensitive skin. When the button is pressed for the third time, the "Extra +3" level is set, thus allowing the selection of 3 rinses in addition to the standard cycle's rinses. The option - started with cycles at a temperature of 40°C - makes it possible to remove major allergens such as pollen, cat and dog hair. With cycles at a temperature higher than 40° a very good level of antiallergic protection is achieved. Press the button again to go back to the "Normal rinse" rinse type. If the current adjustment can be neither set nor changed, the display will show "No Selection" or "No Change".



RAPID

If you select this option, the wash duration will be reduced by up to 50% depending on the selected cycle, thereby guaranteeing simultaneous water and energy saving. Use this cycle for lightly soiled garments.





DELAY TIMER

To set the selected programme to start at a later time, press the button to set the desired delay time. To cancel the delayed start, press the button again until the value "-- h" is shown on the display.



LOCK BUTTON

to lock the control panel, press and hold the button  for approximately 2 seconds. When the display visualises "KEY LOCK ON" the control panel is locked (with the exception of the  button). This prevents unintentional changes to programmes, especially with children near the machine.

To unlock the control panel, press and hold the button  for approximately 2 seconds.

CLEANING AND MAINTENANCE

WARNING

Be sure to turn off the washer dryer and disconnect it from its electrical power supply before performing any cleaning or maintenance operations.

Never use flammable liquids to clean the washer dryer.

CLEANING THE WASHER DRYER EXTERNALLY

Clean the washer dryer's external parts using a soft damp cloth.

Do not use generic detergents, glass detergents, abrasive powders, or other similar products to clean the control panel, as these could damage the printed elements.



CHECKING THE WATER INTAKE HOSE

Periodically check the integrity of the water intake hose. If it is found to be damaged, contact Customer Support or an authorised dealer in order to obtain a replacement hose.

Based on the type of hose:

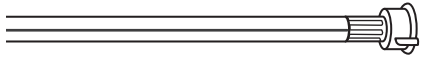
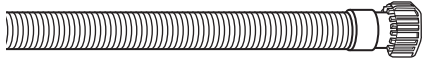

If the water intake hose has a transparent cover, periodically check to make sure that there are no areas where the colour is more pronounced. In such cases, the hose may have a leak and may need to be replaced.

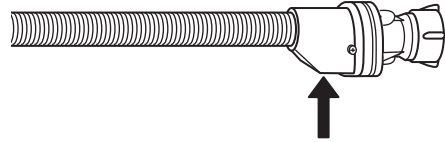
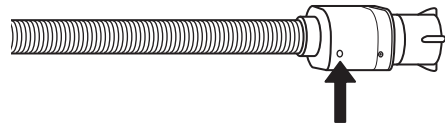

For flood protection hoses: check the safety valve's inspection window (see the arrow). If it's red, this means that the flood protection function has been engaged; in this case, the hose will have to be replaced with a new one. In order to detach the hose, press the release button (if present) and unscrew the hose.

CLEANING THE FILTERS IN THE WATER INTAKE HOSE

1. Close the water tap and unscrew the intake hose.

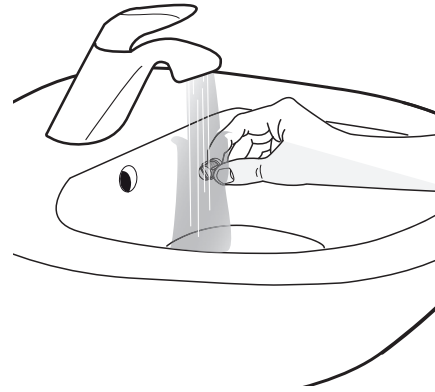
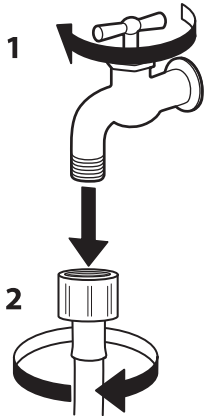

2. Thoroughly clean the mesh filter at the end of the hose using a brush.

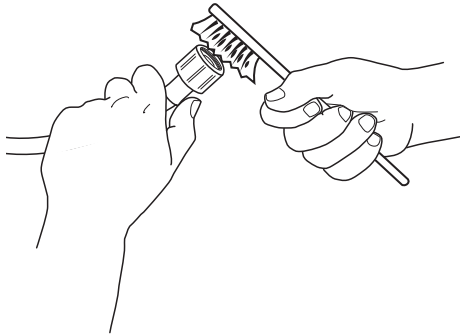

3. At this point, manually unscrew the intake hose from the back of the washer dryer. Using pliers, extract the mesh filter from the valve on the back of the washer dryer and clean it.

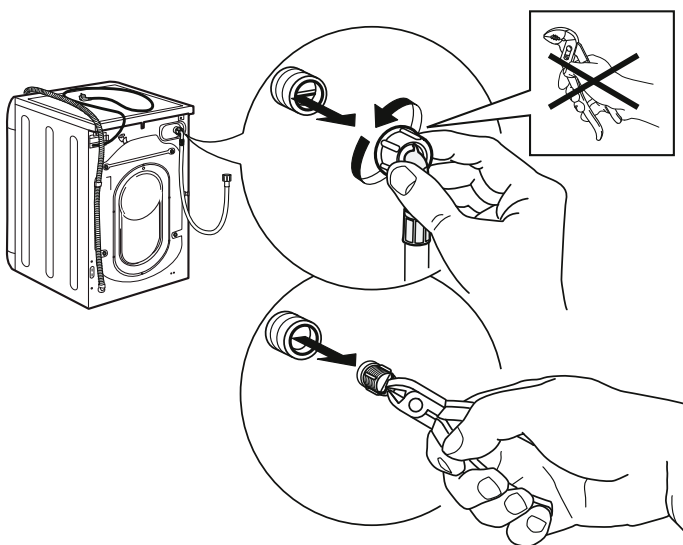

4. Re-insert the mesh filter. Reconnect the intake hose to the water tap and the washer dryer. Do not use tools to connect the intake hose. Open the water tap and check to make sure that all the connections have been tightened properly.

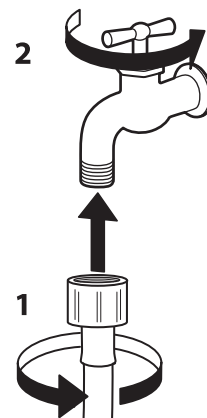
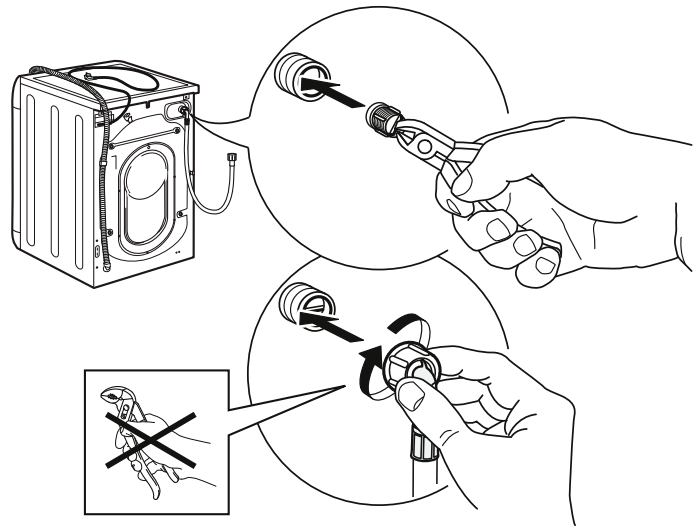

CLEANING THE DETERGENT DISPENSER

1. Remove the detergent dispenser by pressing the release button and pulling on the dispenser at the same time.

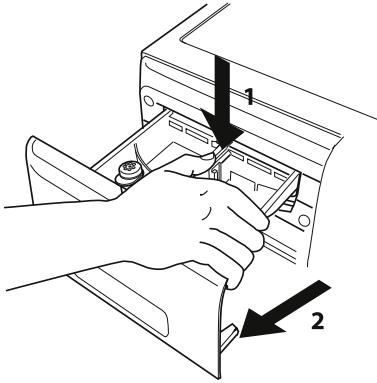

4. Dry with a soft cloth.

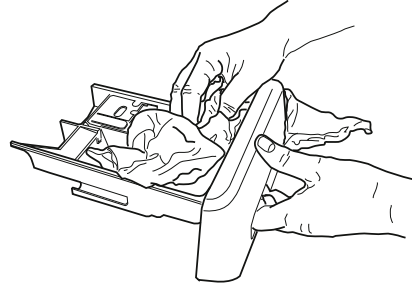

2. Remove the insert from the fabric softener compartment.

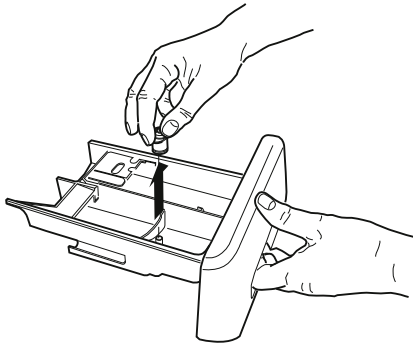

5. Re-install the detergent dispenser and close it.

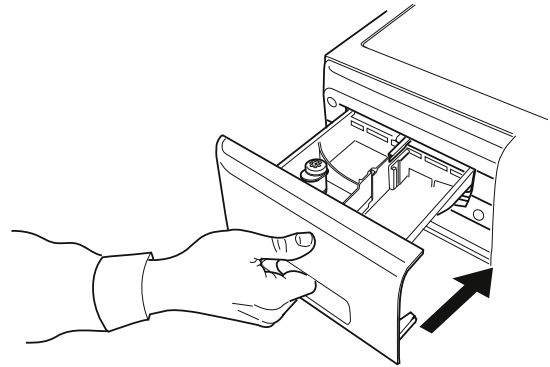

3. Wash the components under running water, taking care to remove all the detergent and fabric softener residues.

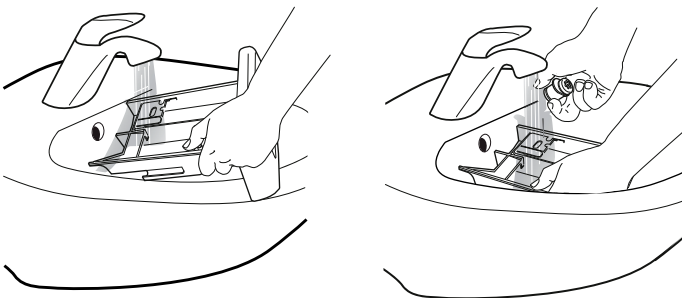

CLEANING THE WATER FILTER / DRAINING THE RESIDUAL WATER

⚠ WARNING

Make sure that the washer dryer has been shut off and disconnected from its electrical power supply before cleaning the water filter or draining the residual water. If a high temperature wash

programme has recently been used, wait for the water to cool before draining it.

The water filter should be cleaned regularly in order to prevent water from remaining inside the appliance after wash cycles due to filter obstructions.

- 1.** Remove the kick panel: Using a screwdriver, do that which is shown in the following figure.

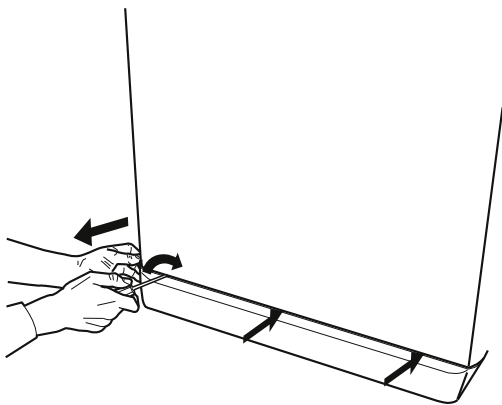

- 2.** Container for the drained water: Place a low and wide container under the water filter in order to collect the residual water.

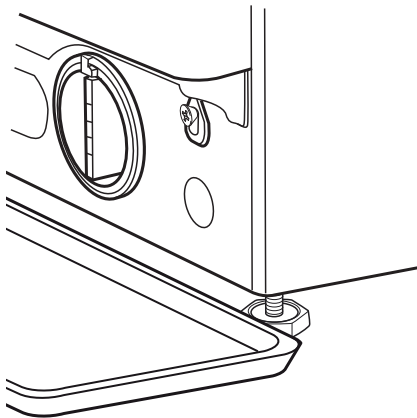

- 3.** Drain the water: Slowly turn the filter counter-clockwise until all the water has come out. Allow the water to flow out without removing the filter. Once the container is full, close the water filter by turning it clockwise. Empty the container. Repeat the procedure until all the water has been drained.

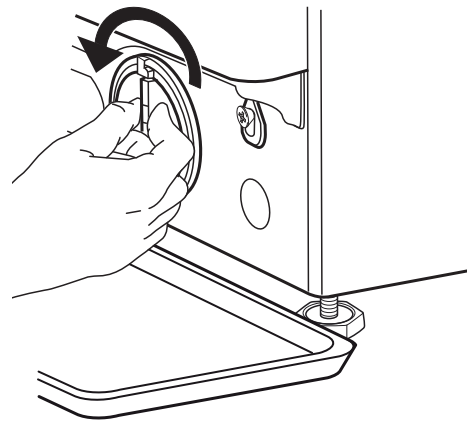

- 4.** Remove the filter: Place a cotton cloth under the water filter in order to absorb any small amounts of residual water. Next, remove the water filter by turning it counter-clockwise.

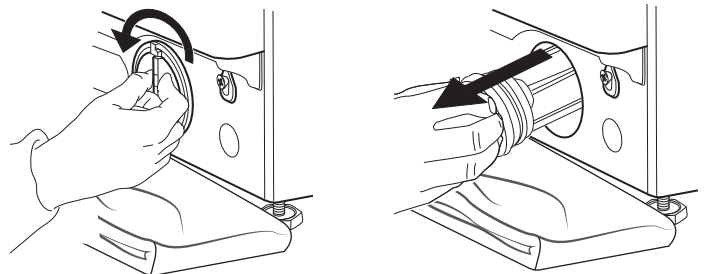

5. Clean the water filter: remove any residues from the filter and wash it under running water.

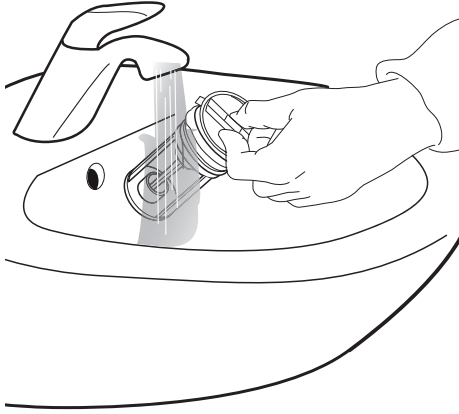

6. Insert the water filter and reinstall the kick panel: Re-insert the water filter by turning it clockwise. Turn it as far as it will go; the filter's grip should be in its vertical position. In order to check the filter's seal, pour about 1 litre of water into the detergent dispenser. Re-install the kick panel.

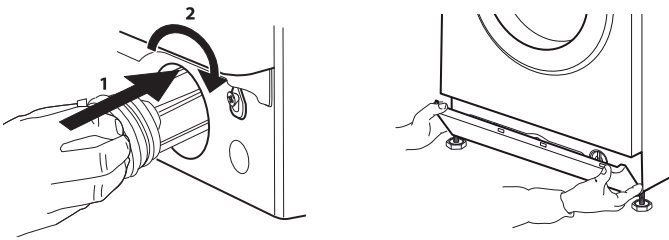

TRANSPORT AND HANDLING



WARNING

Do not lift the washer dryer while holding onto its upper surface.

- 1.** Disconnect the electrical plug and close the water tap.
- 2.** Check to make sure that the door and the detergent dispenser are securely closed.
- 3.** Disconnect the intake hose from the water tap, then disconnect the drain hose. Eliminate all the residual water from the hoses, and secure them in such a way that they will not be damaged during the transport operations.
- 4.** Reapply the transport bolts. Follow the procedure for removing the transport bolts described in the Installation Instructions, in the opposite order.
Important: never transport the washer dryer without having applied the transport bolts.

TROUBLESHOOTING

The washer dryer may sometimes not work properly for certain reasons. Before calling the Support Centre, it is recommended to check to see if the problem can be easily resolved using the following list.

Anomalies:

Possible causes / Solution:

The washer dryer does not turn on.

- The plug is not inserted into the electrical outlet, or not enough to make contact.
- There has been a power failure.
- The door is not fully closed.

The wash cycle does not start.

- The ON/OFF button has not been pressed.
- The START/PAUSE button has not been pressed.
- The water tap is not open.
- A start delay has been set.

The washer dryer does not fill with water (the message "NO WATER, Turn tap on" is shown on the display).

- The water intake hose is not connected to the tap.
- The hose is bent.
- The water tap is not open.
- The mains water supply has been shut off.
- There is not enough pressure.

The washer dryer loads and drains water continuously.

- The START/PAUSE button has not been pressed.
- The drain hose has not been installed at 65 to 100 cm from the ground.
- The end of the drain hose is immersed in water.
- The drain connector on the wall does not have an air vent. If the problem persists after having performed these checks, close the water tap, shut off the washer dryer, and call the Support Centre. If the dwelling is located on one of the uppermost floors of a building, a siphon effect can sometimes occur, thus causing the washer dryer to load and drain water continuously. Special anti-siphon valves are available on the market to prevent these types of problems.

The washer dryer does not drain or does not spin.

- The programme does not include the draining function: with certain programmes it must be activated manually.
- The drain hose is bent.
- The drain line is obstructed.

The washer dryer vibrates excessively during the spin cycle.

- At the time of installation, the drum was not properly unlocked.
- The washer dryer is not level.
- The washer dryer is squeezed between furniture and the wall.

The washer dryer leaks water.

- The water intake hose has not been tightened properly.
- The detergent dispenser is clogged.
- The drain hose has not been properly fastened.

The machine is locked and the display flashes, indicating an error code (e.g. F-01, F-..).

- Shut off the machine, disconnect the plug from the outlet, and wait about 1 minute before turning it back on. If the problem persists, call the Support Centre.

Too much foam is formed.

- The detergent is not compatible with the washer dryer (it must bear the wording "for washing machines", "for hand washing and washing machines", or something similar).
- The dosage was excessive.

The washer dryer does not dry.

- The plug is not inserted into the electrical outlet.
- There has been a power failure.
- The door is not fully closed
- A start delay has been set.
- The DRY function is set to its 0 position.

CUSTOMER SUPPORT SERVICE

BEFORE CONTACTING CUSTOMER SUPPORT

1. Try to resolve any problems you may encounter on your own by consulting the section titled.

TROUBLESHOOTING

2. Shut off the washer dryer and turn it back on to see if the problem persists.

IF THE PROBLEM PERSISTS, CONTACT CUSTOMER SUPPORT

Call the number shown on the warranty booklet, or follow the instructions provided at the **website www.whirlpool.com.hk**

Always provide:
A brief description of the problem.
The washer dryer model (see the data plate inside the door).
Your address and telephone number.

For any repairs that may be required, please contact an authorised Customer Support Centre in order to ensure that the repairs are performed correctly using original spare parts.

繁體中文

產品安全指引、使用說明及安裝指南



感謝您購買惠而浦產品
為了獲得更完善的服務，
請於www.whirlpool.com.hk註冊您的產品

索引	
產品安全指引	
安全指引	28
重要事項：請閱讀並遵循	28
使用說明	
產品介紹	30
產品	30
控制面板	30
洗衣劑盒	31
供水及水管連接資料表	32
機門	32
如何使用洗衣乾衣機	33
首次使用	33
日常使用	33
提示及應用	35
程序表	36
程序	37
選項及功能	38
清潔及保養	39
清潔洗衣乾衣機的外部	39
檢查進水喉	40
清潔進水喉的濾網	41
清潔洗衣劑盒	42
清潔濾網/排走積水	43

搬運和處理	45
故障排除	46
售後服務	48
安裝指南	49

使用洗衣乾衣機前請先細閱產品安全指引。請妥善保存此產品安全指引及使用說明作將來參考。本手冊和洗衣乾衣機本身提供重要的安全警告，請按需要隨時讀取及查察。不當的使用及不當的操作可能會導致的風險，製造商將不負任何責任。

⚠ 除非得到持續監視，否則幼兒(0-3歲)和兒童(3-8歲)應遠離洗衣乾衣機。洗衣乾衣機可由8歲以上之兒童及身體，感官或精神障礙或經驗知識不足的人士操作，前提是此等人士已接受洗衣乾衣機的安全指導及指引，且瞭解使用洗衣乾衣機的相關危險。

兒童不可胡亂玩弄洗衣乾衣機。未經指導，兒童不可進行洗衣乾衣機的清潔及保養工作。

切勿強行打開機門或以它作為踏板使用。

允許使用

⚠ 注意：此洗衣乾衣機不能透過外部控制器或遙控裝置進行操作。

⚠ 此洗衣乾衣機設計只適用於家居或下列之類似環境：如一般商店、辦公室及其他工作環境的職員專用廚房；農莊；供入住酒店、汽車旅館及其他住宅式旅店之顧客使用；提供簡單住宿及早餐服務之旅舍。

⚠ 請確保負載不超過最大乾衣量。(請參閱程序表中的指示)。

⚠ 洗衣乾衣機禁止作為商業用途。洗衣乾衣機不適合戶外使用

⚠ 切勿使用任何溶劑(如鬆節油、汽油等)、含有溶劑，去污粉，玻璃或通用清潔劑，易燃液體洗滌劑；請勿以洗衣乾衣機清洗經溶劑或易燃液體處理過的衣物。

⚠ 不要在洗衣乾衣機中乾洗未經清洗的衣服。

⚠ 物品沾了如烹調油、丙酮、乙醇、汽油、煤油、除斑、松節油、蠟物質和除蠟劑應在放入洗衣乾衣機烘乾之前，先以額外洗衣劑並用熱水清洗。

⚠ 不要在洗衣乾衣機中乾洗未經清洗的衣服。

⚠ 物品如泡沫橡膠(膠乳泡沫)、淋浴帽、防水織物、橡膠備份製品和衣服或裝有泡沫橡膠墊的枕頭不應放入洗衣乾衣機進行烘乾。

⚠ 衣物柔順劑或類似產品應按照柔順劑產品內的說明使用

⚠ 乾衣程序的最後一個階段是無熱(冷卻階段)，以確保衣物保持在一個溫度水平而不導致衣物損壞。

⚠ 除非迅速地取出所有衣物並攤開散熱，否則於乾衣程序結束之前，請勿停止洗衣乾衣機。

⚠ 在乾衣過程，機門會因應過程運行而漸漸變得很熱

⚠ 請勿使用此洗衣乾衣機來乾洗用易燃溶劑(如三氯乙烯)清洗過的衣服。

⚠ 請不要使本機來乾洗泡沫橡膠(膠乳泡沫)或相類似有彈性的物質。

⚠ 確保在乾衣過程中水龍頭是打開。

⚠ 移除衣物袋子內所有物品如打火機，火柴等。

安裝

⚠ 此洗衣乾衣機建議由兩個或更多的人進行安裝處理，避免受傷風險。使用防護手套來執行所有拆封和安裝操作，避免割傷風險。如果要在洗衣乾衣機頂部放置乾衣機，請首先聯繫我們的售後服務中心或您的經銷商，以確認是否可行。只允許使用我們的售後服務中心或您的經銷商提供的專業疊裝工具將乾衣機固定在洗衣乾衣機上。

⚠ 請勿提拉頂板來移動洗衣乾衣機。

⚠ 安裝，包括供水(如有任何接駁電線)，必須由合資格的技術人員按照製造商的說明和本地標準安全法規進行維修。除非在用戶手冊特別聲明，切勿維修或更換任何洗衣乾衣機的部件。兒童應遠離洗衣乾衣機安裝地點。拆開洗衣乾衣機後，確認它沒有在運輸過程中損壞。在出現問題時，請聯絡經銷商或售後服務中心。當完成安裝後，包裝棄掉的材料(如塑膠，發泡膠件等)，應置於幼童無法取得的地方，避免意外的風險。此洗衣乾衣機進行安裝前，必先斷開它的電源連接避免觸電危險。進行安裝時，確保洗衣乾衣機電源線沒有損壞，避免火災或觸電危險。只有當安裝步驟完成後才可啟動洗衣乾衣機。

⚠ 不要在極端的情況下安裝洗衣乾衣機，如：通風不良，溫度低於5°C或高於35°C。

⚠ 確保洗衣乾衣機的四隻腳穩固坐落在地面上，如需，可作調整，並檢查洗衣乾衣機是否完全處於水平位置(利用水平尺量度)。

⚠ 如果是木地板或所謂的「浮隔地板」，(例如某些鑲木或層壓地板)，請將機器放在至少寬/深為60x60厘米以及厚度至少3厘米的一塊夾板上。

⚠ 根據本地供水公司的法規將進水喉管連接到水龍頭上。

⚠ 設計只能使用冷水的型號：切勿連接有熱水供應的水龍頭上。

⚠ 對於帶有熱水供水的型號：熱水進水的溫度絕對不能超過60°C。

⚠ 本洗衣乾衣機用運輸螺栓作固定，以防止運輸途中對其內部造成任何損壞。使用機器前必須拆除運輸螺栓。然後，請使用4個附帶的塑膠蓋把開口蓋。



⚠ 安裝完成後等待數小時使其恢復適合室內的環境，才可開始使用。

⚠ 確保地毯或其他材料不會阻塞洗衣乾衣機底部的通風孔(如您的型號適用)。

⚠ 必須使用新水喉將洗衣乾衣機連接到水源。用過的水喉絕對不能重新使用。

⚠ 水壓必須於0.1 -1 MPa內。

電器警告

⚠ 插座必須能夠拔掉，以切斷電源，或安裝設有開關鍵的插座及按照本地的電器安全標準法連接地線。

⚠ 請切勿使用接駁電線或多頭插座，安裝後電線部份不可被使用者易於接觸。手濕或赤腳接觸到水時請勿使用本產品。若本產品的電源線或插頭有損壞，不能正常運作，或受損，請勿操作。

⚠ 如果電源線損壞，必須根據相同產品更換電源線。電源線只能由符合製造商指導和現行的安全法規合格的技術人員更換以避免觸電的危險。

清潔和保養

⚠ 注意：執行任何維修或清潔操作之前，請先關閉及拔下電源插頭。切勿使用蒸氣清洗本產品。

處理包裝物料

包裝材料完全可回收，並設有可回收標誌：

包裝的各個部分必須根據當前本地廢品處理法規進行處理。

廢棄家用電器

必須根據當前本地廢品處理法規進行處理。有關處理、修復和回收本產品的詳細資訊，請聯繫售後服務中心、家庭廢品處理服務中心或您購買本產品的商店。本洗衣乾衣機依照有關廢棄電器和電子設備(WEEE)的歐盟標準2012/19/EU標示。確保以正確的方式廢棄本產品，可避免因不當的廢棄處理方式而對環境和人體健康造成潛在的負面影響。

這符號表示此機器不能作為家庭廢品處理。應將它交給回收電器和電子設備的適用收集點。

產品介紹

產品

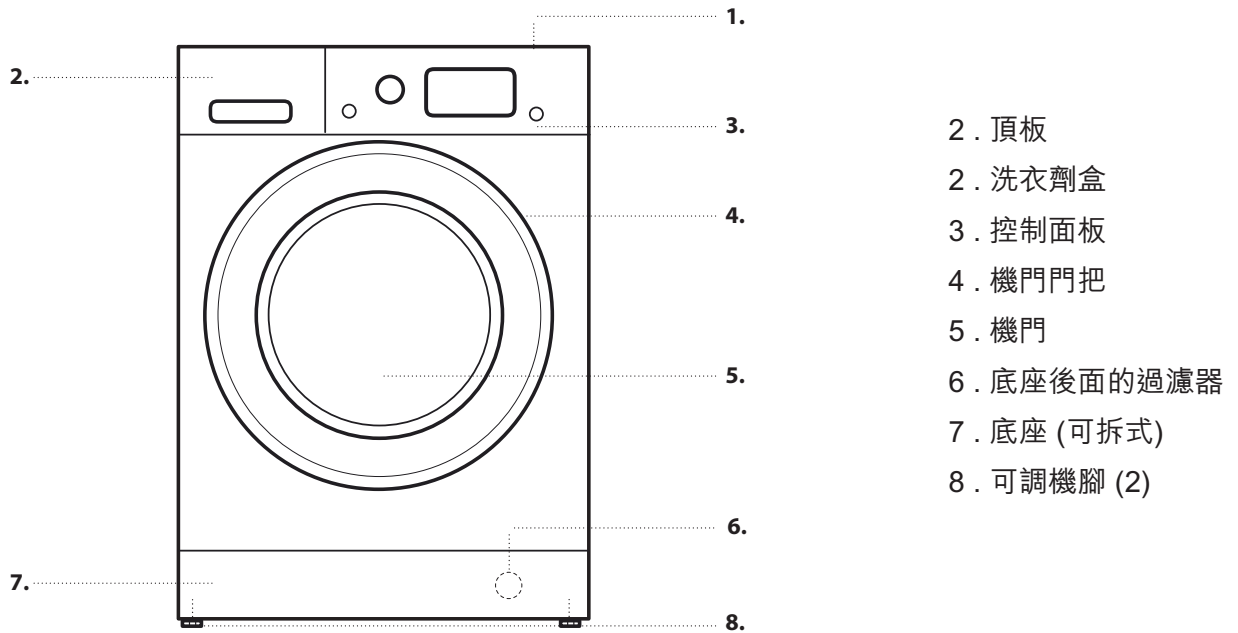

控制面板

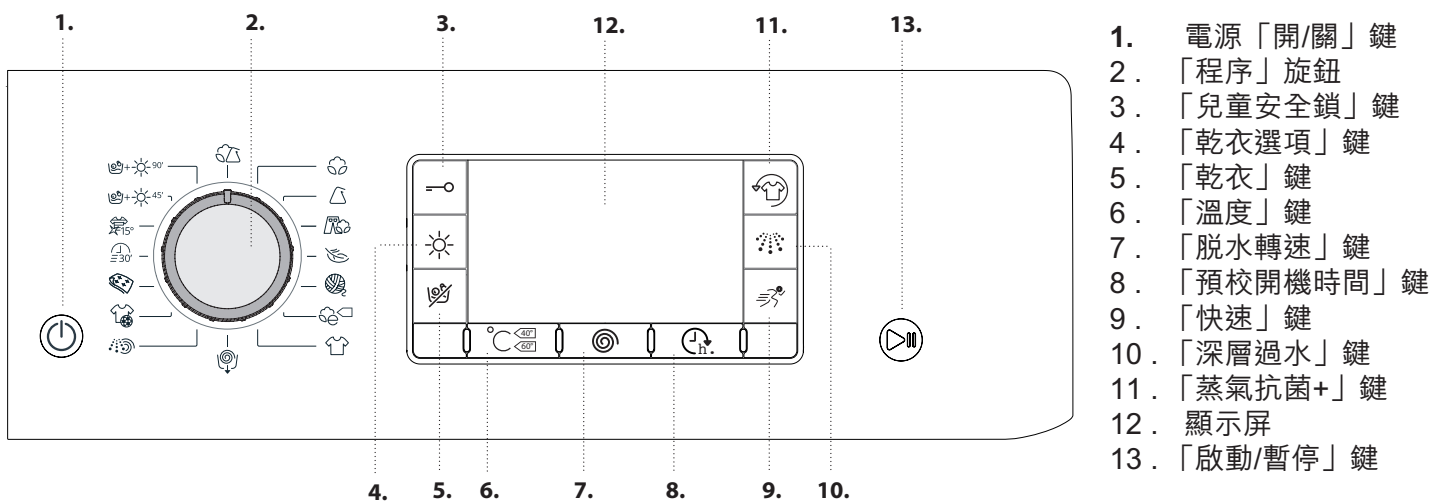

洗衣劑盒

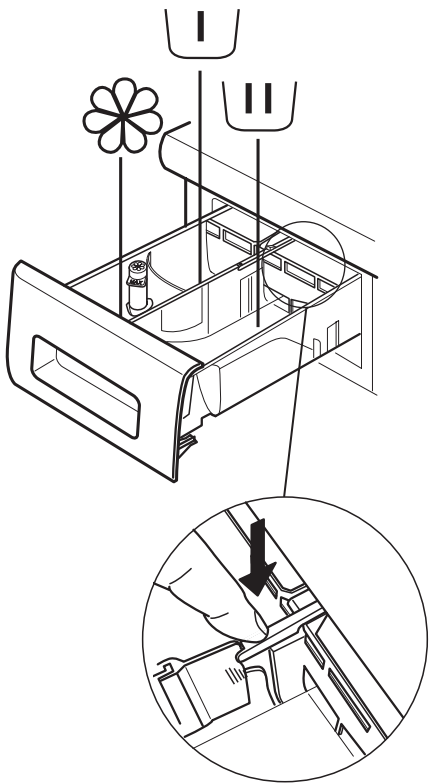

預洗格

- 預洗用洗衣劑



主洗格

- 主洗用洗衣劑
- 去污劑
- 軟水劑



柔順劑格

- 衣物柔順劑
- 衣漿

添加劑只能添加到“MAX”標誌。

鬆開洗衣劑盒按鍵

(按下來鬆開洗衣劑盒，將其抽出並清洗。)

使用洗衣液時，建議把分隔器放置於A格，並確保使用正確的洗衣劑劑量。(分隔器放置於〈使用說明書〉的袋內。)當使用洗衣粉時，請把分隔器放置於B格。

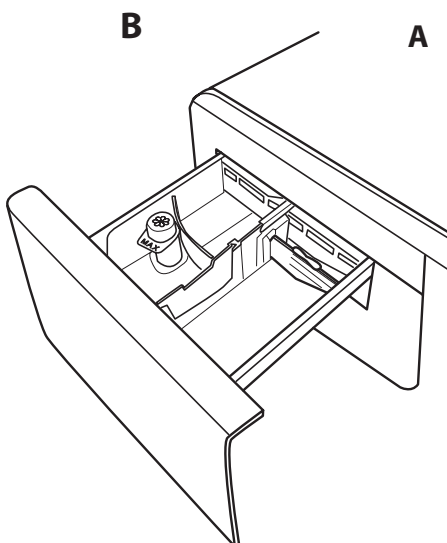

供水及水管連接資料表

水供應類型

冷水

水龍頭

3/4" 螺紋軟管接頭

最低的水壓

100 kPa (1 bar)

最高的水壓

1000 kPa (10 bar)

機門

打開機門，拉動把手。

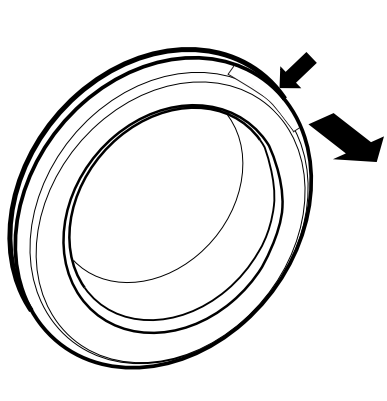



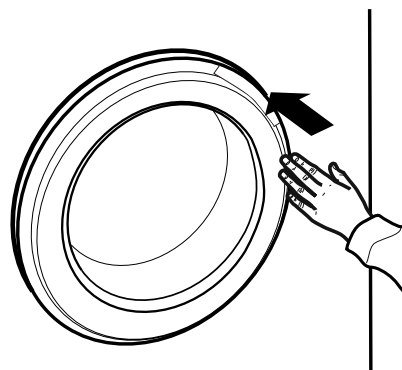

關上機門，握住手柄並推動，這時，您可以聽到喀噠一聲。







如何使用洗衣乾衣機

首次使用

請參閱〈日常使用參考指引〉以得悉如何選擇和啟動程序。

在首次使用本機時，系統會要求您選擇語言及顯示屏會自動顯示多項語言選擇。要選擇所需的語言，請按 °C 及  鍵，如需確認選項，請按下  鍵。如需要更改語言選擇，請關閉本機並同時按下    鍵直至聽到提示音響起，此時，顯示屏會再次顯示語言選擇。

如需要更改顯示屏的亮度(預設為中等值)，請關閉本機並同時按下 ， 及  鍵直至唸聲響起。按下 °C 和  鍵，以選擇所需的亮度，如需確認選項，請按下  鍵。

日常使用

請參閱〈日常使用〉中更多詳細信息功能或參閱最後一頁以得知如何獲得〈使用說明和保養指南〉。

1. 放入衣物

- 按照後頁篇章〈提示及應用〉篇章中的建議，準備好您的衣物。打開機門，放入衣物。一次性鬆散開衣物並放入滾筒中，不要過量。請查閱程序表中所指出的最大建議洗衣量。
- 關閉機門，確保衣物沒有被卡住於機門玻璃和橡膠密封圈之間。關上機門，您可以聽到喀噠一聲。



2. 開啟水龍頭

確保該洗衣乾衣機已連接到水龍頭。並開啟水龍頭。





首次運作

請按以下步驟移除產品製造過程中所衍生的任何殘留物

1. 選擇“棉質”  程序及 60° C 的水溫。
2. 倒入少量的強效洗衣劑於洗衣劑盒的主洗格內 (洗衣劑製造商建議最多使用 1/3 的洗衣劑份量於輕度污染衣物)
3. 啟動程序，請勿再添加任何衣物



3. 開啟洗衣機電源

按下電源「開 / 關」 鍵，「啟動/暫停」 鍵的指示燈會慢慢閃爍及亮起。



4. 選擇及設定程序：

本產品設有以下功能。

- 獨立洗衣
- 洗衣及乾衣
- 獨立乾衣

獨立洗衣

以「程序」旋鈕選擇所需要的程序。顯示屏會顯示所選擇的程序時間，洗衣乾衣機會自動顯示所選擇程序的最高溫度及脫水轉速。如有需要，請以相關的按鈕設定調節溫度及/或脫水轉速。

- 按「溫度」 鍵逐漸降低溫度的設定直到冷洗設定 (“-”) 顯示在顯示屏上。
- 按「脫水轉速」 鍵逐漸降低脫水轉速的設定直到脫水轉速為 (“-”) 顯示在顯示屏上。再次按下「脫水轉速」鍵會調節至所選擇程序的最高的脫水轉速。

選擇所需的選項(如有需要)。

- 按下按鈕以選擇該選項，相關按鈕的指示燈會亮起。
- 再次按下該按鈕以取消選項；相關按鈕的指示燈會熄滅。

! 如選項不適用於所選擇的程序，會發出錯誤提示音及在顯示屏則出現“**No Selection**”的提示文字，此選項不能被選擇。

洗衣及乾衣

可一次過使用洗衣及乾衣程序，請確保負載不超過所選程序的最大乾衣量。(請參閱程序表中的「最大乾衣量」)

1. 請按照〈獨立洗衣〉篇章中的指示以選擇所需要的程序及所需的選項。
2. 按「乾衣選項」☀ 鍵以選擇所需要的乾衣模式。兩種乾衣模式可供選擇：自動感測或自選時間。

- 自動感測乾衣模式附有乾衣程度選擇：

於自動感測乾衣模式下，洗衣乾衣機會把衣物烘乾至所選的乾衣程度。按一下「乾衣選項」☀ 鍵會自動選擇所選程序最高的乾衣程度，再按一下「乾衣選項」便可減少乾衣程度。

可選擇以下的乾衣程度：

額外乾衣 ：適合用於需要完全烘乾的衣物如海綿和浴袍。

一般乾衣 ：足夠乾燥，將在乾衣程序結束後直接放入衣櫃，而不需使用熨燙。

防皺乾衣 ：衣物剩下微濕以減少褶皺，必須掛起風乾。

熨燙乾衣 ：衣物仍略顯潮濕，以便於熨燙。

- 自選乾衣時間模式：

重複按「乾衣選項」☀ 鍵設定自選乾衣時間模式。按該鍵☀ 直至所有乾衣程度選擇出現後，乾衣時間選擇會出現於顯示屏。可選擇乾衣時間由最多180分鐘至最少30分鐘。

若洗衣量大於最大允許的乾衣量(請參閱程序表中的「最大乾衣量」)，請於洗衣程序完成時及乾衣程序開始前，取出部分衣物。步驟如下：

1. 請按照〈獨立洗衣〉篇章中的指示以選擇所需要的程序及所需的選項。
2. 請勿設定乾衣程序。

3. 當洗衣程序完成時，打開機門及取出部分衣物以減少重量。現在請按照〈獨立乾衣〉中的指示。

注意：打開機門前必須先讓洗衣乾衣機冷卻一段時間。

使用兩個預設程序時，☀+☀^{45'} 和 ☀+☀^{90'} 不需要選擇和啟動乾衣程序。

獨立乾衣

此程序用於簡單地烘乾手洗或機洗後的衣物。

1. 選擇合適的乾衣程序(如：「棉質乾衣」程序以烘乾棉質衣物。)
2. 按「乾衣」☀ 鍵只以選擇獨立乾衣。
3. 按「乾衣選項」☀ 鍵以選擇所需要的乾衣模式。兩種乾衣模式可供選擇：自動感測或自選時間。

- 自動感測乾衣模式附有乾衣程度選擇：

於自動感測乾衣模式下，洗衣乾衣機會把衣物烘乾至所選的乾衣程度。按一下「乾衣選項」☀ 鍵會自動選擇所選程序最高的乾衣程度，再按一下「乾衣選項」便可減少乾衣程度。

可選擇以下的乾衣程度：

額外乾衣 ：適合用於需要完全烘乾的衣物如海綿和浴袍。

一般乾衣 ：足夠乾燥，將在乾衣程序結束後直接放入衣櫃，而不需使用熨燙。

防皺乾衣 ：衣物剩下微濕以減少褶皺，必須掛起風乾。

熨燙乾衣 ：衣物仍略顯潮濕，以便於熨燙

- 自選乾衣時間模式：

重複按「乾衣選項」☀ 鍵設定自選乾衣時間模式。按該鍵☀ 直至所有乾衣程度選擇出現後，乾衣時間選擇會出現於顯示屏。可選擇乾衣時間由最多180分鐘至最少30分鐘。

注意：打開機門前必須先讓洗衣乾衣機冷卻一段時間。



5. 加入適量的洗衣劑

拉開洗衣劑盒並按照〈洗衣劑盒〉的描述向相關洗衣劑隔加入洗衣劑。只適用於〈獨立洗衣〉及〈洗衣及乾衣〉程序。



6. 「預校開機時間」

按「預校開機時間」鍵以設定開始程序的時間。詳情請參閱〈選項及功能〉篇章。

7. 啟動程序

按下「啟動/暫停」鍵，指示燈會亮起。機門鎖上及「開門」的指示燈  熄滅。變更正在運行的程序，按下「啟動/暫停」鍵暫停洗衣乾衣機。「啟動/暫停」的指示燈慢慢地閃爍；變更所需設定。再次按「啟動/暫停」鍵繼續運程序。暫停正在運行的程序及打開機門，按下「啟動/暫停」鍵，如「開門」的指示燈  會亮起，您可以打開機門，以添加或取走衣物。再次按「啟動/暫停」鍵繼續運程序。

8. 取消正在運行的程序 (如有需要)

按下電源「開/關」鍵  直至洗衣乾衣機停止運行。只要水位不太高或機內衣物不太熱時，機門會被解鎖，您可以打開機門。如滾桶內仍然有水，機門會被鎖上。如要把機門解鎖，開啟洗衣乾衣機的電源，選擇  程序並設定「脫水轉速」為「- -」。程序完成時，滾桶內的水會被排走，機門會被解鎖。

9. 程序結束後關閉洗衣乾衣機

程序完成時，顯示器上顯示程序結束“CYCLE END”。如「開門」的指示燈  會亮起，您可以打開機門，您可以拿出機內衣物。

按電源「開/關」鍵 ，以關閉洗衣乾衣機。如果不將其關閉，洗衣乾衣機將在程序結束的30分鐘後自動關閉，以節省能源。請讓機門半開，使洗衣乾衣機的內部可以風乾。

提示及應用

請根據以下建議分類衣物

- 衣料類型/護理標籤符號 (棉，混合纖維，合成纖維，羊毛，手洗項目)
- 顏色(請將白色衣物與顏色衣物分開，並將簇新的顏色衣物分開清洗。)
- 大小(不同大小的衣物放在一起清洗時，可改善洗衣及脫水的效率，並可使衣物在洗衣桶內的分佈更為均勻。)
- 纖細衣物(小型衣物，如尼龍絲襪；有鉤扣的衣物，如胸罩及有拉鍊的布袋或枕套。)

清空衣物口袋

- 銀幣、扣針等物品會損毀衣物、洗衣槽及洗衣桶。

衣物護理標籤

在標籤中洗衣缸符號內的溫度，表示用於清洗該衣物項的最高溫度。

-  一般機洗
-  減少機洗
-  避免機洗
-  只可手洗
-  不可濕洗

定期清潔濾網

- 有助避免堵塞或無法正常排水。請參閱〈清潔和保養〉中的〈清潔濾網/排走積水〉篇章。

節能及環境保護

- 運程序時加載最大的建議洗衣量，使所耗用的能源、水、洗衣劑及時間均達最佳效益。
- 洗衣劑用量不要超過製造商指示中標識的用量。
- 使用60°C洗衣程序，而非90°C以節約能源。或使用40°C，而非60°C的洗衣程序。棉質衣料建議使用「 棉質節能洗」40°C或60°C。
- 在使用乾衣功能之前，確保洗衣時選擇高脫水速度，以減少在衣物中的水含量，從而節約能源和時間。

程序表

程序	溫度 °C	最高脫水轉速 轉/分鐘	乾衣功能	最大洗衣量 (公斤)	最大乾衣量 (公斤)	預設洗衣程序 時間 (小時:分鐘)	蒸氣抗菌+	深層過水	快速	洗滌劑及添加劑			建議洗衣劑類別	
										預洗	主洗	柔順劑	洗衣粉	洗衣劑
										☐	☑	⊗	☐	☑
60分鐘混合洗	✱ - 40°C	1000	☑	4.5	4.5	0:59	☑	☑	☑	-	●	○	-	☑
棉質 (2)	✱ - 60°C	1400	☑	9	6	3:55	-	-	-	-	●	○	☑	☑
合成纖維	✱ - 60°C	1200	☑	4.5	4.5	3:25	☑	☑	-	-	●	○	☑	☑
牛仔布	✱ - 40°C	800	☑	4	4	1:35	-	☑	-	-	●	○	-	☑
纖細衣物	✱ - 30°C	--	☑	1	1	1:10	-	-	-	-	●	○	-	☑
羊毛 / 手洗	✱ - 40°C	800	☑	2	2	1:35	-	☑	-	-	●	○	-	☑
棉質節能洗 (1)	✱ - 60°C	1400	☑	9	6	3:40	☑	-	-	-	●	○	☑	☑
棉質節能洗	✱ - 40°C	1400	☑	9	6	3:55	-	-	-	-	●	○	☑	☑
白色衣物	✱ - 90°C	1400	☑	9	6	2:40	☑	☑	☑	● (90°)	●	○	☑	-
脫水及排水 *	-	1400	☑	9	6	0:10	-	-	-	-	-	-	-	-
過水及脫水	-	1400	☑	9	6	0:50	-	☑	-	-	-	○	-	-
運動衣物	✱ - 40°C	600	☑	4	4	1:45	☑	☑	-	-	●	○	-	☑
大型物件	✱ - 30°C	1000	-	2.5	-	2:00	-	☑	-	-	●	○	-	☑
30分鐘速洗	✱ - 30°C	800	-	3.5	-	0:30	☑	-	-	-	●	○	-	☑
護色 15°	15°C	1000	☑	4.5	4.5	1:30	☑	☑	-	-	●	○	-	☑
45分鐘極速洗乾	30°C	1400	☑	1	1	0:45	-	-	-	-	●	○	-	☑
90分鐘混合洗乾	30°C	1200	☑	2	2	1:30	-	-	-	-	●	○	-	☑

☑ 可選擇 - 不可選擇/不適用 ● 需要使用洗衣劑 ○ 選擇性使用洗衣劑
若使用溫度高於50°C的程序，建議使用洗衣粉，並按照就洗衣粉包裝的指示使用。

* 選擇「脫水及排水」☑程序並設定脫水轉速為“- -”以排水。

- 1) 符合標準EN50229 (洗衣) 測試程序：使用60°C的「棉質節能洗」☑程序。
- 2) 較長的棉質程序：使用40°C的「棉質」☑程序。

符合標準EN50229 (乾衣) 測試程序：選擇「棉質節能洗」☑程序及設定一般乾衣程序☐給所有負載。首次負載會根據額定的負載量進行。

在顯示器上或說明書中的程序時間是以標準的情況下計算，實際程序時間會因不同的因素自動調整，如進水溫度和水壓，環境溫度，洗衣劑量，衣物的類型，負載平衡及附加選項等。

程序

請參閱您的衣物護理標籤上的建議。

60分鐘混合洗

適用於由棉、麻、人造纖維及其混合織物製成的輕微或一般骯髒的彈性衣物。

棉質

適用於一般或非常骯髒的毛巾、內衣褲、彈性的棉麻桌布。

合成纖維

適用於一般骯髒的人造衣物纖維，例如(滌綸、綸、黏膠纖維等)或混棉織物。

牛仔布

請在進行洗衣前，把衣物內部反出來，並使用洗衣液。

纖細衣物

適用於質料纖細的衣物。建議洗衣前先把衣物內部反出來。

羊毛/手洗

所有羊毛衣物都可以使用“羊毛”程序進行清洗，甚至印有“只可手洗”標籤的衣物，亦可使用此程序。為了獲得最佳的洗衣效果，請使用專用的洗衣劑，不得超過最大的負載洗衣量

棉質節能洗

適用於一般骯髒的棉質衣物。
40°C及60°C水溫下清洗棉質衣物的最佳耗水和耗電程序。屬能源標籤的參考程序。

白色衣物

通常對於洗滌非常骯髒的毛巾、內衣褲、棉麻桌布及床單等。如彈性的棉、麻布料。只有當選擇在溫度為90°C的程序下，預洗過程會被提供在主洗程序前。在這種情況下，建議一併添加洗滌劑，在預洗和主洗部分。

脫水及排水

脫水及排水程序。適合彈性的衣物

過水及脫水

過水及脫水程序。適合彈性的衣物。

運動衣物

用於洗滌輕度污染運動服裝(運動服，短褲，等等)。為了獲得最佳的洗衣效果，我們建議載入不超過“程序表”中所示的最大負載量。我們建議使用洗衣液。

大型物件

專門為洗滌羽絨類的衣物而設。如雙或單羽絨被，墊子和防寒短上衣或防風雨衣。建議負載的衣物不超過洗衣桶內 $\frac{3}{4}$ 的容量。為了獲得最佳的洗衣效果，我們建議使用洗衣液。

30分鐘速洗

適用於快速清洗較少污漬的衣物：30分鐘的快洗程序，可節省時間及能源。最多可負載4公斤的衣物。

護色15°

此程序將衣物使用冷水(15°C)洗衣，幫助保護衣服的顏色，也可以節省用於把水加熱的大部分電量，同時保持良好的洗淨效果。適用於有輕微骯髒的未染色的衣物。此程序可提供的效果作對比，只需15°C水溫，便可達40°C的潔淨效能。

45分鐘極速洗乾

適用於快速清洗及烘乾較少污漬而由棉、合成纖維製成的衣物。可於45分鐘內清洗及烘乾最多1公斤的衣物。

90分鐘混合洗乾

適用於快速清洗及烘乾較少污漬而由棉、合成纖維製成的衣物。可於90分鐘內清洗及烘乾最多2公斤的衣物。

選項及功能

選項 - 控制面板的獨立選項

! 如該選項不適用於所選擇的程序，則會發出錯誤的警告的提示音及在顯示屏則出現 “No Selection” 的提示文字。此選項不能被選擇

蒸氣抗菌+

如果與洗衣程序聯繫起來，此功能透過產生蒸氣來抑制機內不良氣味(專門用於洗滌)，完成蒸氣過程後，洗衣乾衣機會溫和地將衣物翻滾。當「蒸氣抗菌+」功能與乾衣程序相互關聯時，由於滾筒以慢速旋轉，這可以防止頑固的摺痕在衣物產生。

「蒸氣抗菌+」功能會在程序結束後開始進行，這翻滾時間可最長達約6小時，並且您可以在任何時段透過按下控制面板上的任何按鍵或旋鈕中斷程序。並需要等待大約5分鐘，機門才能打開。

深層過水

此功能可為皮膚敏感人士提供所需的過水程序，按下「深層過水」鍵，按至“Extra +1”程度，這可在標準程序過水後。選擇額外過水1次，並可除去所有洗衣劑的殘留。再次按下「深層過水」鍵，並按至“Extra +2”程度，這可進行以標準循環過水，來選擇兩次的額外過水；建議敏感性皮膚人士使用。當按下「深層過水」鍵第三次的時候，“Extra +3”程度會被設置，因此，除了標準循環的過水之外，還會進行3次過水。此選項 - 以40°C溫度的洗衣程序開始 - 主要可以去除過敏原，如花粉，貓毛和狗毛。當洗衣程序溫度高於40°C時，抗過敏保護效果表現則達到非常高的水平。再次按下「深層過水」鍵，返回到“正常過水”的類型。

如果現有的調整既不能設置也不能改變，顯示屏會顯示 “No Selection” 或 “No Change”。



快速

如要選擇此功能，洗衣的運作時間將減少50%，這是取決於所選定的洗衣程序而定，從而保證可同時節省水及能源，此程序適用於輕度污染的衣物。

預校開機時間

按此選項鍵可讓你將程序延遲開始，如要取消「預校開機時間」功能，請再次按下相關按鈕直至顯示屏顯示 “-- h”，即代表功能被取消。

兒童安全鎖

如要鎖定控制面板，請按下「兒童安全鎖」鍵  大約2秒鐘，控制面板即被鎖定。當顯示屏顯示 “KEY LOCK ON” 即表示控制面板已被鎖定(只有「開/關」 鍵可如常運作。

尤其當孩子接近洗衣乾衣機時，此可防止非故意的程序改動。如要解除鎖定的控制面板，按下「兒童安全鎖」鍵  大約2秒鐘，控制面板即解除鎖定。

清潔和保養

警告

請勿使用易燃液體來清潔洗衣乾衣機。

執行任何清潔和保養之前，請先拔下電源插頭。

清潔洗衣乾衣機的外部

用柔軟濕布清洗。用軟布抹乾洗衣乾衣機的外部。

不要使用玻璃或通用的清潔劑，去污粉或類似的清潔控制面板。



檢查進水喉

定期檢查進水喉是否變脆和爆裂。如進水軟管損壞，應聯絡售後服務中心或您的經銷商處購買同類型新水喉進行更換。根據軟管類型：

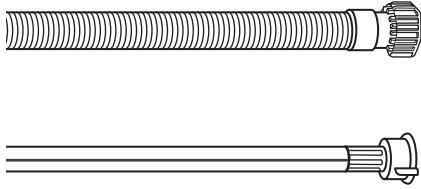

定期檢查進水喉是否變脆和爆裂。如進水軟管損壞，應聯絡售後服務中心或您的經銷商處購買同類型新水喉進行更換。根據軟管類型：

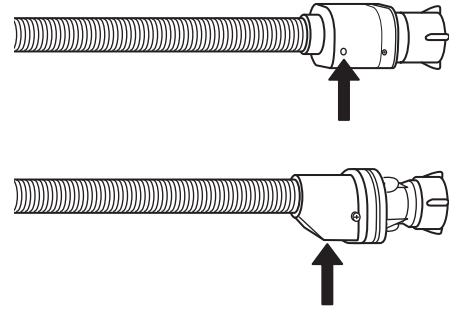

保險入水喉：應定期檢查安全閥檢視窗(見箭咀)：如呈紅色，說明安全閥已經啟用，此時就必須更換水喉。按下釋放按鈕(如有)，而擰開軟管。

清潔進水喉內的濾網

1. 關掉水龍頭並從水龍頭上鬆開進水喉。

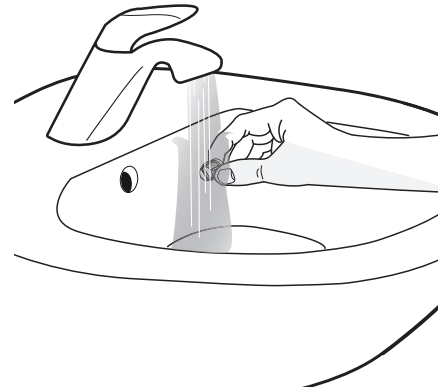
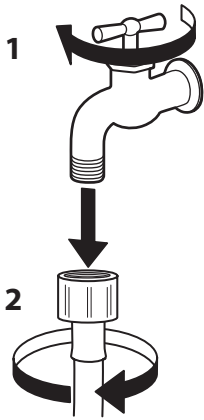

4. 裝回濾網並將進水喉擰回機上。不要使用工具來連接進水喉。打開水龍頭並確認各連接位均完全不漏水。

2. 用刷子仔細清潔在水喉端的濾網。

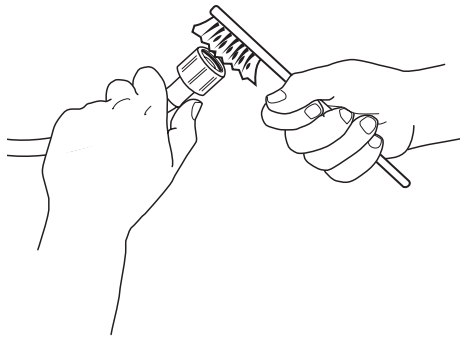

3. 拆下洗衣乾衣機後方的進水喉。用通用鉗子將濾網從洗衣乾衣機接頭上拆下並清潔。

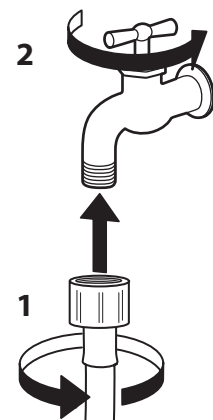
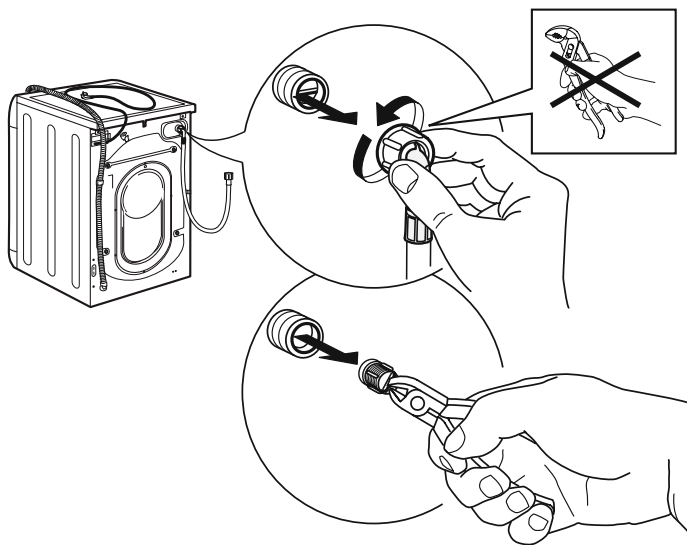
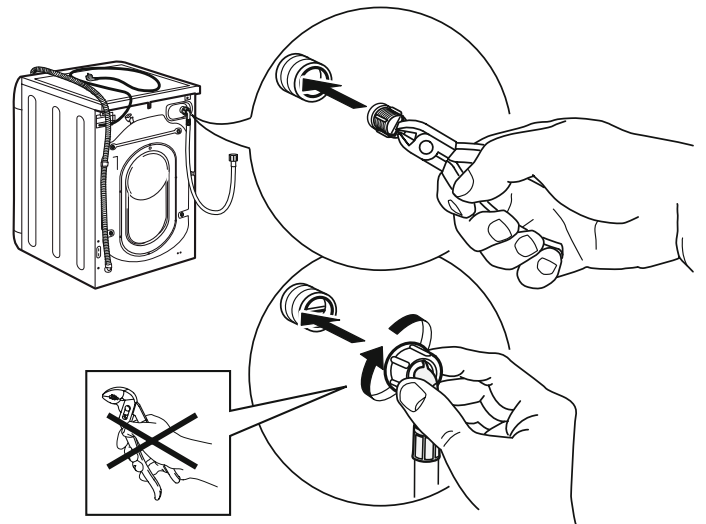

清潔洗衣劑盒

1. 拉出洗衣劑盒鬆開按鈕並同時將其全部抽出。

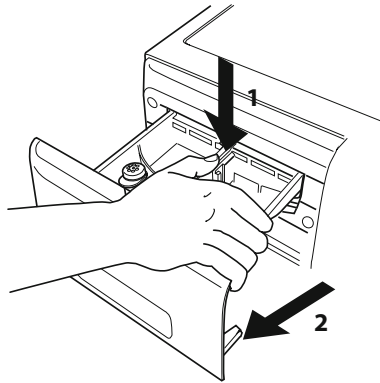

4. 用軟布清潔盒格。

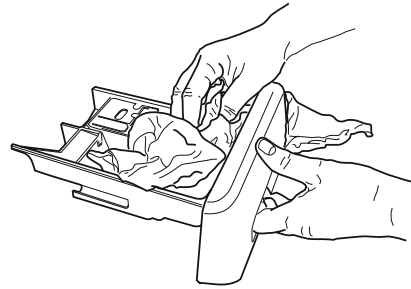

2. 抽出洗衣劑盒。同時抽出洗衣劑盒的嵌件。

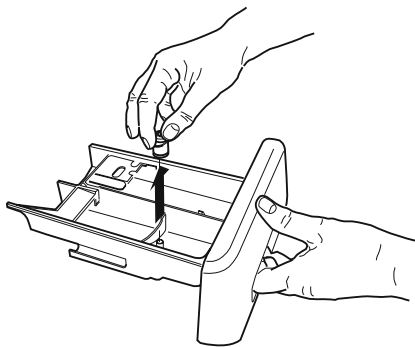

5. 重新裝入洗衣劑盒並推回洗衣劑盒格內。

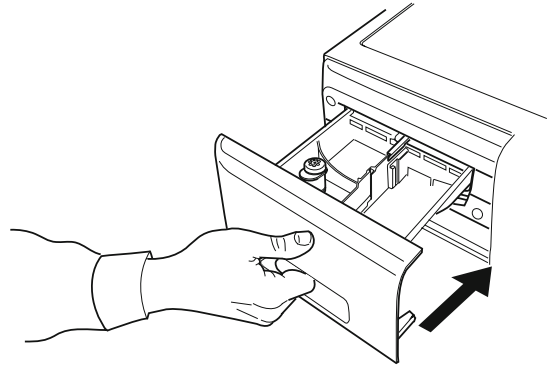

3. 用水沖洗所有部件，清除所有洗衣劑或柔順劑漬。

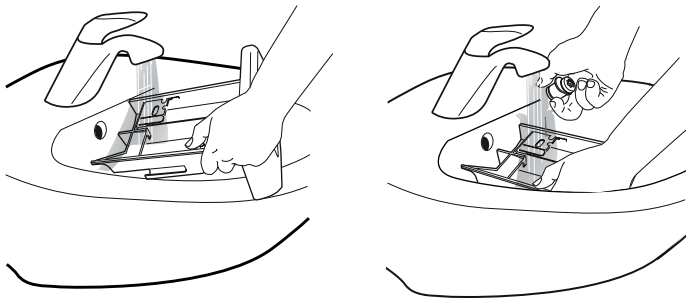

清潔濾網/排走積水

警告

清潔濾網或排走積水前先讓洗衣乾衣機停止運轉並拔除洗衣乾衣機電源插頭。如果您使用過熱洗程序，排走洗衣乾衣機內的水前應等待水已冷卻下來。

請對過濾器進行定期檢查並清潔，以避免由於阻塞過濾器導致水不能排出。如果水不能排出，顯示屏會顯示過濾器可能被堵塞。

- 1. 鬆開底座：**請跟隨下圖，用螺絲批鬆開。

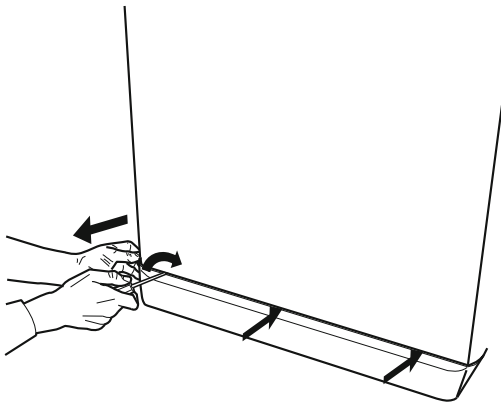

- 2. 放置一個容器：**將寬闊且扁平的容器放在濾網下方收集排水。

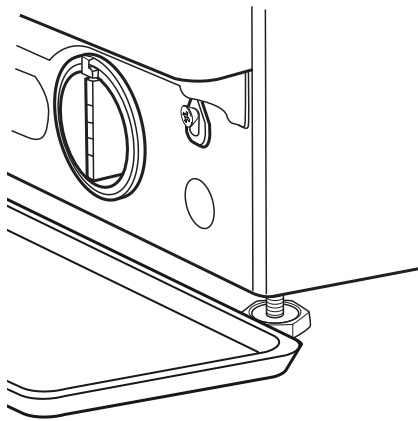

- 3. 排走積水：**逆時針轉動濾網而不用拆開濾網，並緩慢打開直至排走全部水。當該容器是滿水，將濾網按順時針方向轉緊。清空容器，重複這個步驟，直到水全部流出。

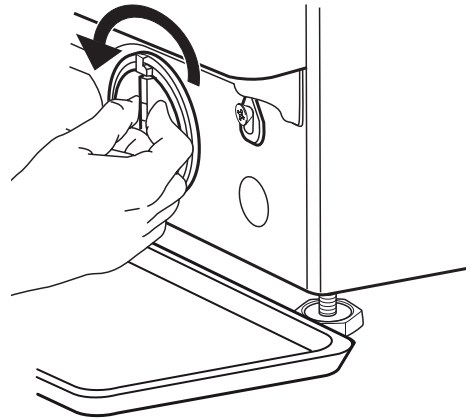

- 4. 抽出濾網：**把棉布放在濾網下方以吸收餘下的少量積水，然後按逆時針方向打開抽出濾網。

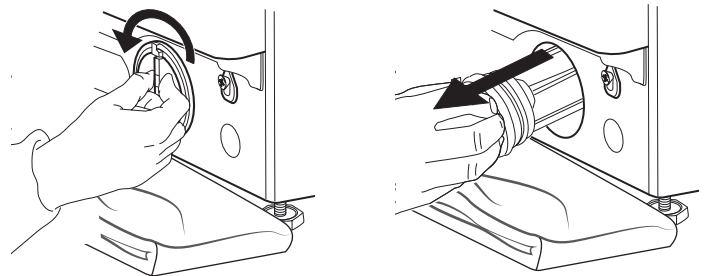

- 5.** 清洗濾網：用水沖洗並除去濾網殘渣。

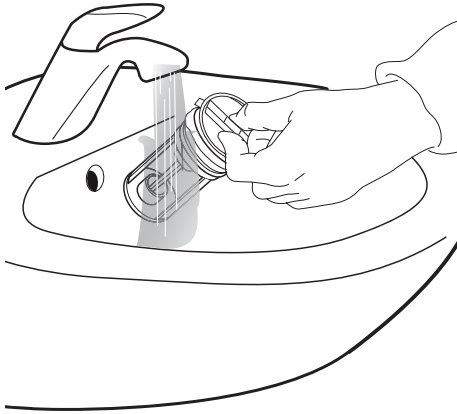

- 6.** 插入濾網塞並裝回底座：將濾網塞回原位，然後按順時針方向轉緊到最深位置。濾網手柄必須處於垂直位置。可以倒入約1公升的水於洗滌盒測試濾網是否已轉緊。然後裝回底座。

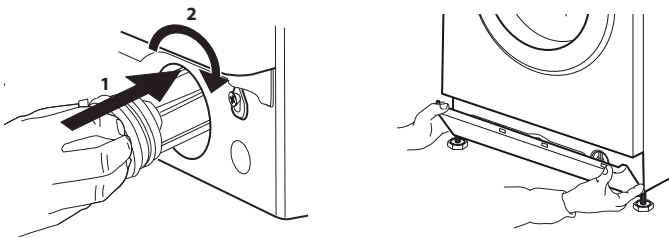

搬運和處理

警告

搬運時，切勿提拉洗衣乾衣機的頂板。

- 1.** 拔除洗衣乾衣機電源插頭。
- 2.** 檢查並確定機門和洗衣劑盒都已正確關閉。
- 3.** 拆除水龍頭與入水喉和排水管與排水喉的連接位，排出軟管內的所有積水，此整理以使它們不怕在運輸過程中損壞。
- 4.** 重裝搬運螺栓：按照安裝指南並以反方向的形式安裝搬運螺栓。
重要：未有固定搬運螺栓時請勿搬運洗衣乾衣機。

故障排除

該洗衣乾衣機可能因為某些原因而不能正常運作。聯絡售後服務中心之前，建議先自行進行檢查，看問題是否可以使用以下列表的簡易方法解決。

異常：

洗衣乾衣機無法啟動。

原因 / 解決方法：

- 插頭沒有正確插在插座內。
- 電源故障。
- 機門未正確關閉。

洗衣程序無法啟動。

- 「開/關」沒有被按下。
- 「啟動/暫停」沒有被按下。
- 水龍頭關閉。
- 已設定預校開機時間。

洗衣乾衣機無法進水。

「信息“NO WATER, Turn tap on”」
顯示在顯示屏上。

- 進水喉未連接到水龍頭。
- 進水喉可能扭曲。
- 水龍頭關閉。
- 自來水供應關閉。
- 供水壓力過低。

洗衣乾衣機不停入水和排水。

- 「啟動/暫停」沒有被按下。
- 排水喉尚未正確地安裝於離地面65至100厘米的位置。
- 排水喉的端部浸於水中。
- 牆壁上的排水管不具有通氣孔。
- 如果檢查後問題仍然存在，關閉水龍頭，關閉洗衣乾衣機，並聯絡售後服務中心。如果住宅樓層位於建築物的最上層，有時會發生虹吸現象，從而使洗衣乾衣機不停入水和排水。

洗衣乾衣機無法排水和脫水。

- 當程序不包括排水功能：某些程序必須額外設定排水功能。
- 排水喉可能扭曲。
- 排水喉阻塞。

脫水時機身震動。

- 搬運螺栓尚未拆除。
- 洗衣乾衣機四個機腳不水平。
- 洗衣乾衣機被擠壓於家具和壁之間。

洗衣乾衣機漏水。

- 進水喉尚未正確地擰緊。
- 洗滌劑盒堵塞
- 排水喉尚未正確地擰緊。

洗衣乾衣機被鎖定，顯示屏閃爍，顯示錯誤代碼(如: F-01, F-)。

- 關閉洗衣乾衣機電源並拔下電源插頭。約一分鐘後重開洗衣乾衣機。
- 如果故障仍然存在，請聯絡我們的售後服務中心。

洗衣劑過量。

- 洗衣劑不適用於洗衣乾衣機(參考洗衣劑的註明，「只適用於洗衣乾衣機」，或者類似的註解。
- 劑量過大。

洗衣乾衣機無法乾衣。

- 插頭沒有正確插在插座內。
- 電源故障。
- 門未正確關閉。
- 已設定預校開機時間。
- 乾衣功能的設置是0

致電售後服務中心前：

1. 嘗試自行解決問題請參閱〈故障排除〉。

故障排除

2. 重新啟動洗衣乾衣機，檢查洗衣乾衣機是否仍舊無法正常運作

若洗衣乾衣機仍舊無法正常運作，請致電售後服務中心。

請致電保用證上顯示的號碼，或按照以下網址上的指引

www.whirlpool.com.hk

請說明：

- 簡單的故障說明。
- 洗衣乾衣機型號 (參閱機門內的銘牌)
- 您的完整地址和電話號碼。

對於任何維修，使用我們授權的售後服務中心，以確保適當的維修和使用原廠零配件。

INSTALLATION GUIDES 安裝指南

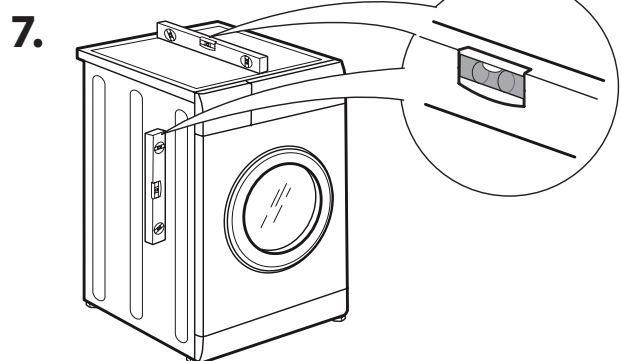
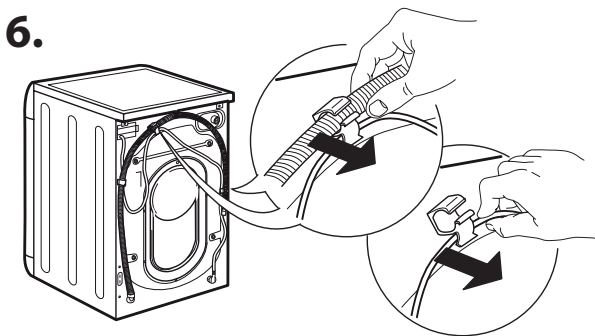
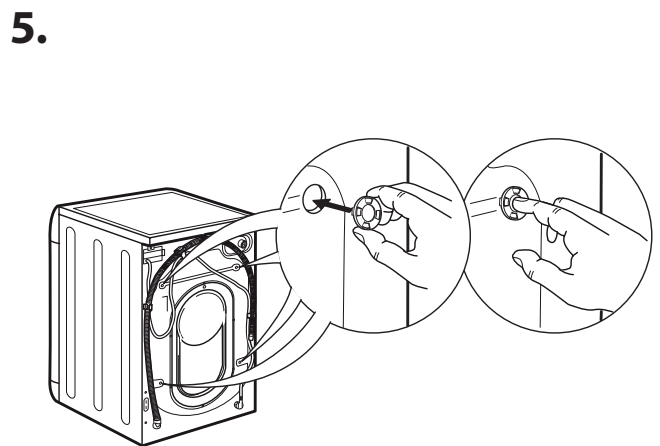
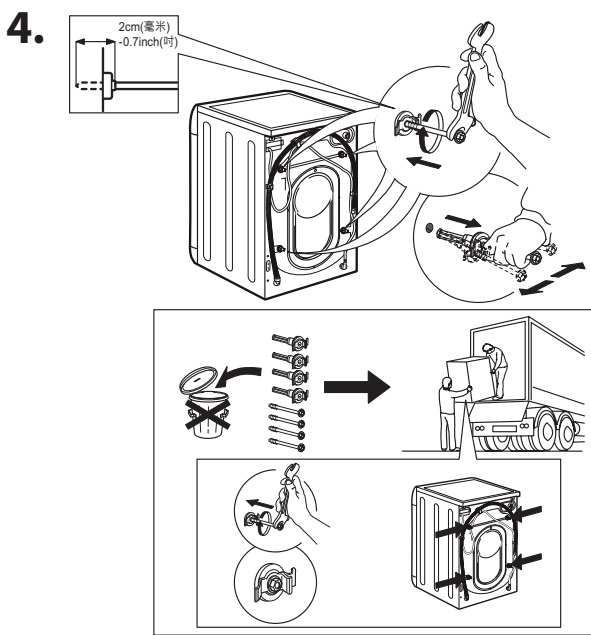
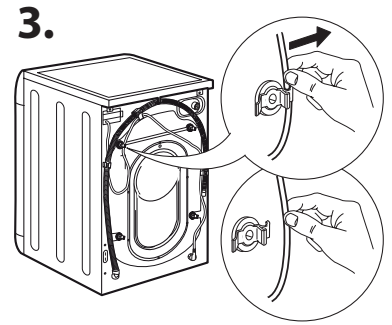
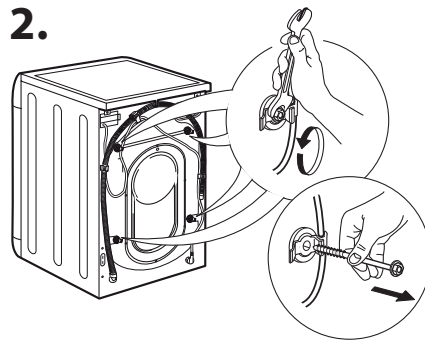
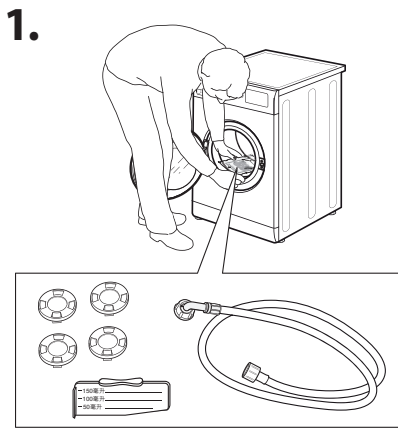
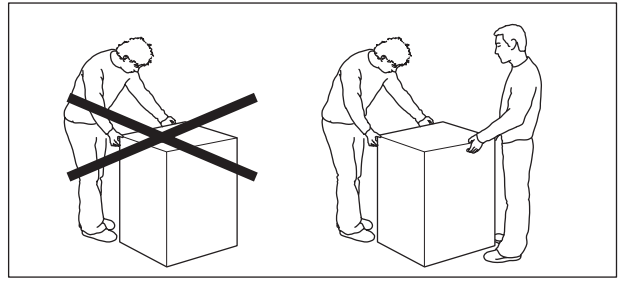
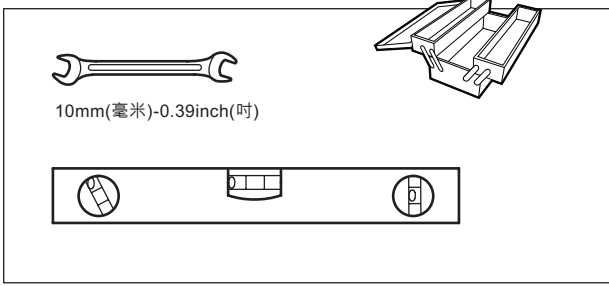

8.

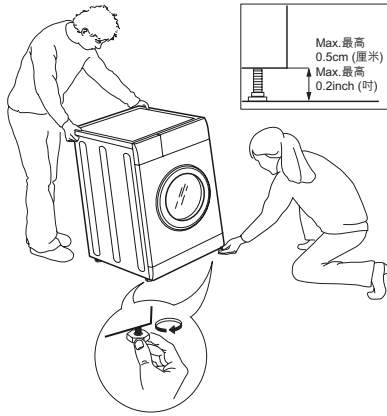

9.

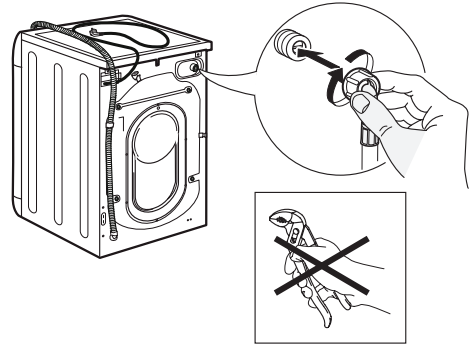

10.

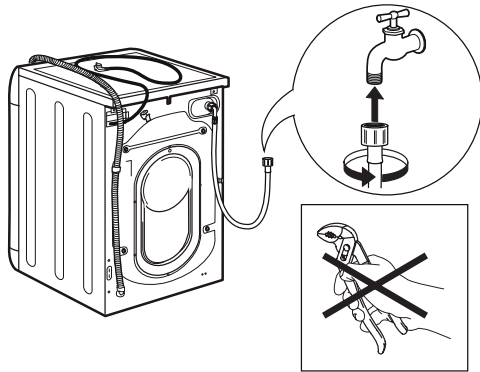

11.

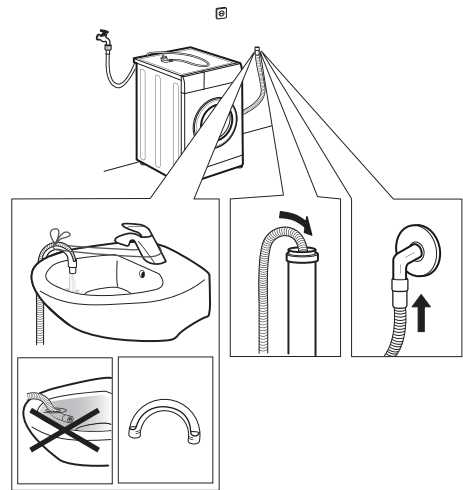

12.

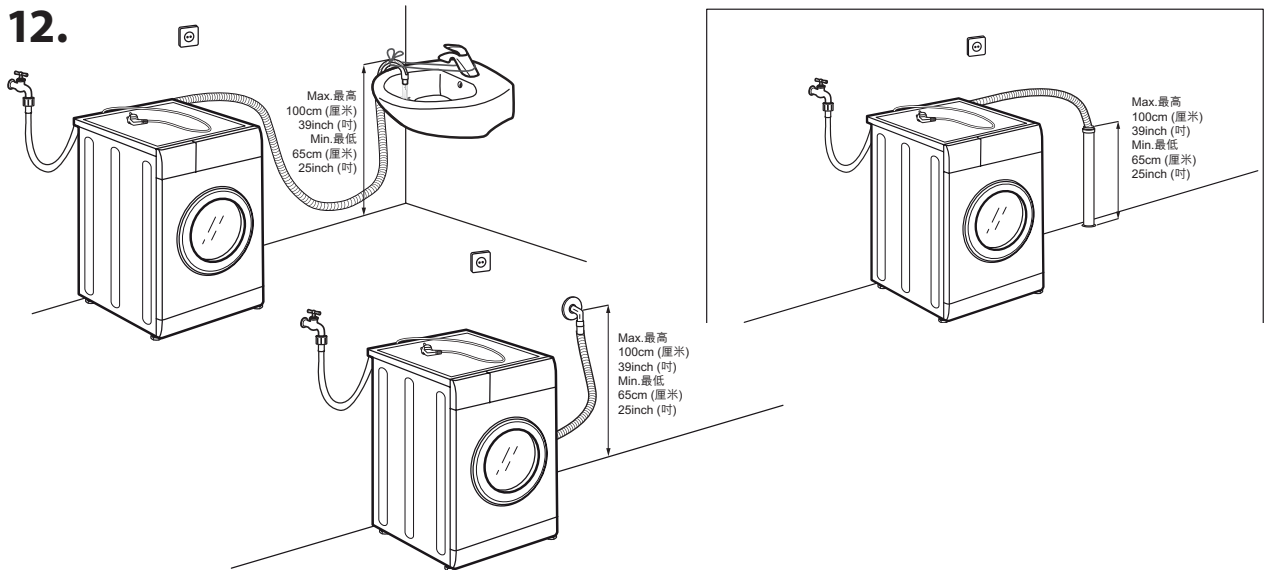

13.

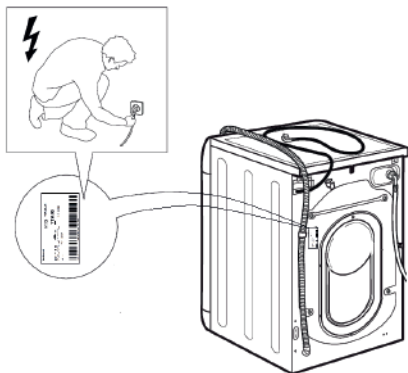

14.

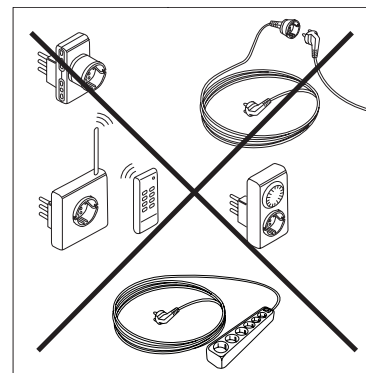

Whirlpool® Registered trademark/TM Trademark of Whirlpool group of companies
All rights reserved - <http://www.whirlpool.com.hk>

註冊商標/惠而浦集團的TM商標

版權所有 翻印必究 - <http://www.whirlpool.com.hk>



1 1 2 4 4 4 8 6



Whirlpool